



**Design Standards,
Standard Specifications,
and
Standard Details
for
Water and Wastewater**

January 2022

Van Buren Municipal Utilities
P.O. Drawer 1269
Van Buren, AR 72957

Table of Contents

Revision History

Introduction

Design Standards

Standards Page

100 – Project Standards	1
200 – Site Standards.....	11
300 – Water Standards.....	13
400 – Sanitary Sewer Standards	25
500 – Electrical and Instrumentation Standards	35

Forms

Corresponding Water Meter and Address Verification Form
Sewer Facility Operation and Maintenance Agreement

Standard Specifications

Specifications Page

Section 210 – Trenching and Backfilling	1
Section 220 – Pavement Repairs.....	9
Section 230 – Site Restoration.....	19
Section 310 – Water Line Improvements	25
Section 320 – Water Valves and Hydrants	37
Section 330 – Testing of Water Line Improvements	47
Section 410 – Sanitary Sewer Line Improvements.....	51
Section 420 – Sanitary Sewer Manholes.....	59
Section 430 – Testing of Sanitary Sewer Improvements	73
Section 510 – Electrical Improvements	79
Section 520 – Emergency Standby Generator	85
Section 530 – Automatic Transfer Switch	91
Section 540 – Motor Control Center.....	97
Section 550 – Telemetry and Instrumentation	109

Standard Details

M01 – Chain Link Security Fence
M02 – Chain Link Fence Gate
M03 – Bollard
M04 – Facility Identification Sign

Table of Contents – Continued

S01 – 4-Ft. Diameter Cast-In-Place Manhole
S02 – 6-Ft. Diameter Cast-In-Place Manhole
S03 – Manhole Drop
S04 – Shallow Manhole
S05 – Manhole Grade Adjustment
S06 – Sewer Service Lateral Connection
S07 – Encasement Around Vertical Service Connections
S08 – Curb Stamp for Utility Service Location
T01 – Trenching and Bedding Notes
T02 – Trench Backfill and Gravel Surface Repair
T03 – Trench Backfill and Asphalt Surface Repair
T04 – Trench Backfill and Concrete Surface Repair
T05 – Trench Backfill and Restoration of Native Area
T06 – Trench Bedding and Backfill for 24" and Larger Gravity Sewers
T07 – Class “B” Granular Bedding and Backfill
T08 – Concrete Encasement
T09 – Encasement Pipe Notes
T10 – Encasement Pipe
T11 – Pipe Blocking for Bends and Tees
W01 – Gate Valve
W02 – Tapping Sleeve and Valve
W03 – Fire Hydrant Assembly
W04 – Water Valve Box Adjustment
W05 – Water Service Meter Connection
W06 – Typical Duplex Meter Assembly
W07 – 1-1/2" and 2" Water Service Meters
W08 – Blowoff Hydrant or 2" Private Fire Protection Service
W09 – 2" or Larger Air/Vacuum/Combination Air Valve Assembly
W10 – 8 Inch Blowoff Assembly
W11 – Tracer Wire and Terminal Box
W12 – Water Line/Sewer Force Main Marker
W13 – Water and Sewer Line Separation
W14 – Water Meter Vault 3" and 4" Meters (1 of 2)
W15 – Water Meter Vault 3" and 4" Meters (2 of 2)
W16 – Adjustable Pipe Support

VAN BUREN MUNICIPAL UTILITIES
Design Standards, Standard Specifications, and Standard Details

Revised January 2022

Revision Date	Revisions
May 14, 2014	Adopted by the Van Buren Municipal Utilities Commission
February 15, 2022	Revisions adopted by the Van Buren Municipal Utilities Commission

THIS PAGE LEFT BLANK INTENTIONALLY

INTRODUCTION

1.01 PURPOSE

- A. The purpose of this document is to set the minimum standards for the design and construction of water and wastewater improvements in areas serviced by the City of Van Buren Municipal Utilities.

1.02 AUTHORIZATION

- A. The creation of the water and sewer Design Standards, Standard Specifications, and Standard Details was authorized by the Van Buren Municipal Utilities Commission in 2013. The initial version of these documents was adopted by the Van Buren Municipal Utilities Commission on May 14, 2014, and they were subsequently revised during 2021. This current version of the Design Standards, Standard Specifications, and Standard Details was adopted by the Van Buren Municipal Utilities Commission on February 15, 2022.

1.03 AVAILABILITY OF SERVICE

- A. The following is an update of the Availability of Service Policy adopted by the Van Buren Water and Sewer Commission on April 9, 1990.
 - 1. Each customer contemplating the purchase or re-use of vacant lots is hereby advised that the City of Van Buren Municipal Utilities will make every effort to supply valid information so that the Owner and/or purchaser may determine whether or not water and/or sewer service lines to the lot(s) in question currently exist. Should service lines exist and be determined by the City of Van Buren Municipal Utilities to be in useable condition, the customer will not have to pay new connection fees.
 - 2. If the parcel does not have an existing service or the existing service is not useable the customer shall be required to pay new connection fees.
 - 3. For existing water service lines to be considered useable the line must be capable of delivering adequate volume and/or pressure to adequately serve the proposed needs of the Owner.
 - 4. The Owner is responsible for a determining whether an existing sewer service line is free of debris and obstructions as well as free from leaks. The Owner is also responsible for determining whether a new or existing sewer service line has sufficient grade to drain properly and that the proposed or existing building finished floor elevation is high enough to prevent sewer from backing up into the build in case of stoppage.
 - 5. The City of Van Buren Municipal Utilities makes no guarantee as to the accuracy of the information provided for determining the functionality of service lines. In addition, the City of Van Buren Municipal Utilities does not guarantee that currently established service lines and/or main lines will be useable in the future.
 - 6. If service lines cannot be found, and/or if existing lines are inadequate or unusable by the customer in any manner, new connection fees will be required.

7. If service is not available at the premises or if the existing main lines no longer have adequate volume and/or pressure to adequately serve the proposed needs of the Owner, the Owner will be required to extend or improve the nearest adequate main line past the last driveway of any new proposed use of the property. Any extension of a main line shall be constructed in accordance with the City of Van Buren Municipal Utilities Design Standards, Standard Specifications, and Standard Details, latest edition.

END OF INTRODUCTION

DESIGN STANDARDS

City of Van Buren Municipal Utilities

SECTION 100 – PROJECT STANDARDS

1.01 GENERAL

- A. These standards and specifications are provided to outline the City of Van Buren’s procedures and minimum criteria for the design and construction of water and sewer improvements within the City of Van Buren Municipal Utilities (VBMU) service area.
- B. Water and Sewer Facilities shall be designed and constructed in accordance with these standards and specifications. Preparation of construction drawings, reports, easement and right-of-way documents, exhibits, and other project documentation shall be coordinated with the requirements of these project standards and the accompanying specifications. Notations referring to “construction plans” or “Drawings” indicate requirements for additional project or scope of work information that should be addressed or provided in the construction drawings.
- C. Projects shall be designed to meet the applicable standards created and adopted by the Arkansas Department of Health (ADH) and the Arkansas Division of Environmental Quality (ADEQ).
- D. The Arkansas State Plumbing Code as adopted by the City of Van Buren, the City Municipal Code, and all ordinances of the City of Van Buren are included in these standards by reference.
- E. In case of conflict between design standards, regulatory codes, standard construction details, or other contract documents, the most stringent requirement shall govern. All conflicts shall be brought to the attention of VBMU for clarification and/or direction.
- F. Addenda and/or revisions to these standards and specifications may be issued periodically by VBMU and will be made available to the public and contractors at the VBMU offices at 2806 Bryan Road, Van Buren, Arkansas. Users of this text are urged to review the latest revisions or editions to the standards and specifications to apprise themselves of any revisions or additions.
- G. Where data and standards are referenced from outside sources, unless otherwise noted, the latest edition of each source applies.
- H. Unless specific products or materials are mentioned in these Design Standards, refer to the City of Van Buren Standard Specifications for minimum requirements for construction materials and approved equipment and manufacturers.
- I. The Developer of the project involving the construction of public utilities shall be responsible for procuring all necessary permits and licenses, paying all charges and fees, acquiring and recording all easements, and giving all notices necessary and incidental to the work at no cost to VBMU.
- J. All permits required to accomplish the work shall be the responsibility of the Developer, the Contractor, or their authorized representative. Such permits may include but are not limited to permits for work within Arkansas Department of Transportation (ARDOT) right-of-way, railroad crossing, or encroachment permits, ADEQ “Notice of Intent” for Erosion Control Storm Water Drainage Permit, ADEQ Short Term Activity Authorization, and U.S. Army Corps of Engineers (USACE) Section 404 and other environmental permits. Construction shall not commence until the appropriate permit approvals have been submitted to VBMU.
- K. These Design Standards and the accompanying Standard Specifications are intended to set forth minimum standards of quality for the construction of water and sewer facilities to be accepted by

VBMU. These Design Standards are not intended to replace the standard of care for any design or related services provided by a professional engineer, and VBMU expects that such services will be provided with the care and skill ordinarily used by professional engineers under similar circumstances, time and locality. The Standard Specifications are not intended to replace the Engineer's Specifications or Contract Documents; however, construction of all water and sewer facilities shall meet or exceed these standards of quality for all materials and construction. VBMU shall not be responsible nor bear any liability for the Contractor's means, methods, techniques, sequences and procedures of construction, or safety precautions and programs incident thereto, nor shall VBMU be responsible for any actions resulting from the direction of the Engineer. VBMU shall not be responsible for the acts or omissions of the Contractor(s), Subcontractor(s), Supplier(s), or any other person or organization performing or furnishing any of the Work. Nothing contained in these Design Standards, or the Standard Specifications shall be construed as an endorsement or warranty by VBMU of any product, material, or workmanship. VBMU shall not be responsible nor bear any liability for the failure of any material or resulting from any method of construction.

- L. The City of Van Buren Municipal Utilities encourages participation of local, small, minority, and woman owned business enterprises in the procurement of goods, services, and construction.

1.02 DEFINITIONS AND ABBREVIATIONS

- A. ADEQ – The Arkansas Department of Energy and Environment, Division of Environmental Quality
- B. ADH – The Arkansas Department of Health
- C. ANSI – American National Standards Institute
- D. ARDOT – The Arkansas Department of Transportation
- E. ASTM – American Society for Testing and Materials
- F. AWWA – American Water Works Association
- G. Best Management Practices (BMPs) – Stormwater management control measures that address water quality problems from urban runoff caused by land development and increases in impervious land surfaces. BMPs are typically designed to reduce stormwater peak flows and runoff volumes and/or address nonpoint source pollution through implementation of a variety of methods including stormwater detention, evapotranspiration, and filtration/infiltration. EPA has published a list of stormwater BMPs in *National Menu of Best Management Practices (BMPs) for Stormwater* (EPA).
- H. Builder – The person, group or corporation who is responsible for the construction of residential, commercial or industrial buildings and structures that will require water and/or sanitary sewer services.
- I. Commercial (or commercial occupancy) – Business, industrial, warehouse, institutional, hotel, apartment, or other occupancies not covered under the Residential definition.
- J. Construction Plans – The plans or drawings that show the scope and character of the work to be performed, and which have been prepared by the Engineer. May be used interchangeably with the term Drawings.
- K. Contractor – The person, group or corporation responsible for constructing the improvements.

- L. Customer – The person, entity or corporation which has assumed the legal obligation to pay for water or sewer service when that service is provided to a either a single or multi-unit property.
- M. Developer – The person, group or corporation who is responsible for the construction of improvements.
- N. Drawings – The plans or drawings that show the scope and character of the work to be performed, and which have been prepared by the Engineer. May be used interchangeably with the term Construction Plans.
- O. Engineer – The designer of record who is responsible for the development of construction plans and specifications and for the preparation of engineering reports, analyses, etc. All public water and sanitary sewer improvements must be designed by a Professional Engineer, licensed to practice in the State of Arkansas. Unless otherwise noted, the procurement of professional engineering services for private development work shall be the responsibility of the Developer or Builder. It is the Engineer’s responsibility to provide design and construction documentation to VBMU, as defined in these Standards and Specifications, to facilitate the review, approval and acceptance of water and sewer improvements into the public system.
- P. EPA – The United States Environmental Protection Agency
- Q. FAA – Federal Aviation Administration
- R. GPM – Gallons per minute (unit of flow)
- S. GPS – Global Positioning System
- T. HI – Hydraulic Institute
- U. NEC – National Electrical Code
- V. NEMA – National Electrical Manufacturers Association
- W. NFPA – National Fire Protection Association
- X. NSF – NSF International (formerly the National Sanitation Foundation)
- Y. Residential (or residential occupancy) – Single or multi-family dwellings including duplexes, triplexes, quadplexes, condominiums, apartments, and similar structures not used for commercial purposes.
- Z. Telemetry – Equipment and processes for the collection of data, the monitoring of equipment or structures, and the transmission of such data from remote locations.
- AA. 10 State Standards, latest edition – The Great Lakes Upper Mississippi River Board standards for the design and construction of water and wastewater improvements
- BB.USACE – The United States Army Corps of Engineers
- CC. VBMU – The City of Van Buren Municipal Utilities

1.03 SUBMITTALS

- A. Submittals that have been reviewed and approved by the Engineer shall be submitted to VBMU for review and approval in all cases where the proposed product differs from the specific product listed in the material specification.
- B. Submittals for the products that are listed in the material specification shall also be submitted to VBMU upon review and approval by the Engineer for VBMU's records.
- C. VBMU shall review submittals for conformance with the operational characteristics of the specified equipment. Review by VBMU shall not necessarily include a determination of the suitability of the proposed equipment or material for the specific application.
- D. A minimum of two (2) weeks shall be allowed for VBMU review of submittals.
- E. The words "or approved equal" shall mean that the proposed material or item shall perform adequately the duties imposed by the general design and shall be at least equal in design and materials to that specified by using the name of a product, manufacturer, and/or vendor. Any party proposing to substitute an "equal" shall obtain prior approval of VBMU. VBMU shall make final approval of such items or materials judged to be "approved equal".

1.04 PRE-CONSTRUCTION REQUIREMENTS

- A. Prior to the start of construction, the following documents and information shall be submitted to VBMU for review and/or project documentation purposes:
 - 1. A complete set of plans and specifications prepared and sealed by a Professional Engineer who is licensed in the State of Arkansas. Plans shall be submitted on 22" x 34" or 24" x 36" sheets. Construction plans for all public water and sanitary sewer improvements must be approved by VBMU prior to the commencement of construction.
 - 2. Documentation from the Arkansas Department of Health stating that the project has been reviewed and approved for construction.
 - 3. Design calculations including all assumptions.
 - 4. Proof of the Contractor's general public liability and property damage insurance including vehicle coverage. Proof of insurance must also be submitted to the Van Buren Mayor's Office.
 - 5. Proof of Contractor's qualification to do business in the State of Arkansas. Contractors must be applicably licensed under the terms of Act 150 of the 1965 Acts of the Arkansas Legislature, including subsequent amendments. Prequalification statements are not normally required. However, VBMU shall consider the following criteria in evaluating the Contractor's qualifications.
 - a. Financial Responsibility.
 - b. Experience and performance records on similar work.
 - c. Ability to adequately and competently supply construction equipment and personnel to complete the Work as designed.

- d. Contractors may be requested to submit financial statements prior to commencement of construction.
 - e. VBMU reserves the right to disallow a proposed Contractor if VBMU believes that doing so would be in the best interest of the City of Van Buren Public Water and Sewer System.
 - f. It is presumed that Contractors have familiarized themselves with applicable standards, specifications, laws, rules, regulations, and requirements pertaining to the planned construction work.
- B. At the request of VBMU, the Developer or their designated representative (e.g., the Engineer) shall conduct a preconstruction conference prior to commencing work. The conference attendees shall minimally include the Engineer, the Contractor, and representatives from VBMU. The Developer or their representative shall produce and distribute a written record of the conference proceedings.

1.05 REQUIREMENTS DURING CONSTRUCTION

- A. The Contractor is responsible for safety on the job including traffic control and trench or excavation safety in accordance with federal, state and local laws and regulations.
- B. The Contractor is responsible for locating underground utilities. The Contractor must contact Arkansas 811 (1-800-482-8998) prior to performing any excavation.
- C. The Engineer shall provide full time inspection services during any portion of the project when the Contractor is installing underground utilities. Full or part time inspection of the entire utility installation portion of the project may be required at the discretion of VBMU. Provide the name and contact information of the qualified inspector to VBMU prior to the start of construction and advise VBMU of any subsequent change in inspection responsibilities.
- D. The Engineer shall also be responsible specifying and reviewing for all required quality control and assurance testing.
- E. Only authorized VBMU personnel are permitted to operate public water system valves. Under no circumstances shall the Developer or the Contractor operate any valve on the system.
- F. Any construction requiring connections, excavations, or any related work on or nearby the existing VBMU Public Water and Sewer System shall be performed during the hours of 8:00 a.m. to 5:00 p.m. Monday through Friday, excluding VBMU recognized Holidays. Exceptions may be approved on a case-by-case basis when circumstances warrant an urgent necessity in the interest of public health and safety.

1.06 POST-CONSTRUCTION REQUIREMENTS

- A. Following the completion of construction, the Engineer shall provide the following documentation to VBMU, if applicable:
 - 1. Bacteriological testing showing passing results on two (2) consecutive days for potable water lines and appurtenances including storage tanks and reservoirs.
 - 2. Records showing the results of all quality assurance testing required by the Van Buren Municipal Utilities Standards and Specifications, latest edition.

3. A letter from the Engineer certifying that all construction work was completed in accordance with the approved plans and specifications. Evaluation of the completeness and conformity of the work shall be based on the Engineer's on-site construction observations and the Engineer's qualified opinion.
4. Documentation showing the construction cost of the project.
5. Copies of all approved material and equipment submittals.
6. Warranty and other manufacturer documentation for equipment and materials.
7. Startup documentation and certifications for materials and equipment.
8. Equipment Operations and Maintenance manuals.
9. Recorded easement documents showing the dedication of easements where required. The Developer is responsible for the legal filing of all deeds and easements and any expenses associated with such filing.
10. A complete set of record drawings showing the constructed referenced stationing, GPS coordinate location, and elevations relative to mean sea level (msl) for all valves, manholes, service line connections, meter box locations, etc.
 - a. The Engineer shall conduct a final inspection to verify the location and elevation of all improvements and confirm that they are properly constructed and are correctly notated on the record drawings.
 - b. Record drawings shall include following location information, if applicable:
 - 1) Fire hydrants, including top nut elevation
 - 2) Water valves, including operator nut elevation
 - 3) Pipe fittings
 - 4) Water service saddles
 - 5) Water service saddles used for testing
 - 6) Water meters
 - 7) Tapping sleeves
 - 8) Any other pipe penetrations
 - 9) Steel encasement pipe
 - 10) Details for vertical offset water lines
 - 11) Manholes, including rim and invert elevations
 - 12) Pipe sizes and invert elevations, upstream and downstream
 - 13) Service wyes
 - 14) Service cleanouts

B. Provide the following data in appropriate spreadsheet format:

1. Pipe

- a. Manufacturer
- b. Material
- c. Diameter
- d. Production run or code
- e. Pressure rating

2. Valves

- a. Manufacturer
- b. Model number
- c. Year manufactured
- d. Type
- e. Diameter
- f. Pressure rating

3. Hydrants

- a. Manufacturer
- b. Model number
- c. Year manufactured
- d. Depth of bury, including extensions

4. Pumps

- a. Manufacturer
- b. Model number, including impeller and motor model number
- c. Motor HP
- d. Voltage
- e. Designation of operational electrical phase
- f. Rated simplex and duplex pump flow and head conditions

5. Air Release/Air Vacuum/Combination Valves

- a. Manufacturer
- b. Model number
- c. Diameter
- d. Pressure rating

C. Submit two (2) copies of all documentation listed in Part A. Submit two (2) hard copies on paper plus one (1) electronic copy in indexed PDF format on Compact Disc or USB Storage Device. Hard copies of Record Drawings shall be provided on 22"x 34" or 24"x 36" sheets. Other required supporting documentation shall be provided on 8-1/2"x 11" and 11"x 17" sheets in 3-ring binders, and all pages shall have reinforced, punched edges.

D. Provide a one (1) year maintenance bond in the amount of 10% of the construction cost of public water and sewer improvements to VBMU upon project completion. The maintenance warranty shall be for a period of twelve (12) months following the written acceptance of improvements by VBMU. The warranty shall be for any repair, reconstruction, replacement, or maintenance that

occurs during the warranty period because of the failure of materials and workmanship. Other types of surety bonds may be acceptable with prior approval by VBMU.

- E. The Project Engineer shall submit a points file for each water and sewer improvement. Survey points shall include northing, easting, and elevation coordinates in the Arkansas State Plane North Coordinate System and using the North American Vertical Datum of 1988 (NAVD 88). Points shall be located and measured using survey-grade GPS or conventional surveying equipment after the completion of construction. The Engineer shall also provide an AutoCAD drawing file (.dwg format in most recent version) of the associated improvements. Coordinate points, including descriptors, shall be provided for the following objects:
1. Water valves
 2. Water lines
 3. Fire hydrants (center of top nut)
 4. Water service saddles
 5. Water meters
 6. Manholes
 7. Sewer lines (include upstream and downstream invert elevations)
 8. Wastewater valves (if not part of the pump station)
 9. Pump stations (center of pump station wet well)
 10. Sewer service wyes
 11. Sewer service cleanouts

1.07 DRAFTING STANDARDS

- A. These standards have been established for the purpose of ensuring uniformity in the design and drafting techniques of projects to be submitted for review and acceptance.
1. All projects shall have a title sheet which shall include the following:
 - a. General overall area map
 - b. Vicinity location map
 - c. Name/title of the project including street name or section number if applicable
 - d. Name of the Project Builder/Developer (for private development projects) or VBMU (for public works projects)
 - e. Name of the responsible design Engineer(s)
 - f. Professional Engineer's seal(s) indicating appropriate licensing in the State of Arkansas and an Arkansas Certificate of Authorization indicating authority to practice as a corporation in the State of Arkansas
 - g. List of Sheets (may be included as a separate sheet)
 2. All projects shall include a sheet with a site plan map detailing the location of the project.
 3. All sheets shall have a title block that shows the project name, the sheet name, the responsible design Engineer's name, and a list of all revisions.
 4. All sheets shall be numbered, with total number of sheets included, e.g., Sheet 4 of 12. Exceptions to this rule may be granted by VBMU for larger or more complex projects.
 5. Include standard detail and specifications sheet(s) as applicable.

- B. High quality bonded paper (20 lb. minimum) shall be used for all originals and reproduction “originals” to be submitted as record drawings. Any drawings deemed to be inadequate or unacceptable by VBMU will be rejected.

END OF SECTION 100 – PROJECT STANDARDS

THIS PAGE LEFT BLANK INTENTIONALLY

SECTION 200 – SITE STANDARDS

1.01 SITE PREPARATION

- A. All easements and rights-of-way associated with repair or improvements to the City of Van Buren Municipal Utilities (VBMU) water and sewer systems shall be cleared of obstructions as needed to facilitate the installation and maintenance of said improvements. Excessive or unnecessary clearing shall be avoided.

1.02 EROSION CONTROL

- A. The Developer is responsible for meeting all erosion control requirements set by the United States EPA, Arkansas Department of Environmental Quality, and the City of Van Buren. The Developer shall prepare and obtain all necessary permits, install and maintain all required Best Management Practices for stormwater runoff, and submit all required notifications and documentation including the payment of all applicable fees.

1.03 STREAM AND WETLAND CROSSINGS

- A. If the project requires the crossing of a water of the United States or a water of the State of Arkansas, the Developer is responsible for obtaining a USACE Section 404 permit and an ADEQ Short Term Activity Authorization (STAA).
- B. The Contractor shall follow all requirements specified in the applicable permits.

1.04 SITE RESTORATION

- A. All disturbed areas shall be restored at a minimum to a mowable condition following construction in accordance with the included specifications. At a minimum, all disturbed areas shall be graded to drain and seeded, fertilized, and mulched to prevent erosion. Vegetative cover acceptable to VBMU shall be established before the project is accepted as being completed.

1.05 STREET CUTS

- A. All crossings of public streets and alleys within the city limits of the Van Buren shall be performed in accordance with the latest edition of the “City of Van Buren Regulations for Street Cuts and Standards for Their Repair Ordinance.”
- B. All crossings of public streets outside of the city limits of the City of Van Buren shall be performed in accordance with the latest standards of Crawford County.
- C. All crossing of Arkansas highway shall be permitted by the ARDOT. All crossings of state highways shall follow all applicable ARDOT Standards and shall be in accordance with the approved permit application.
- D. The Developer or Contractor shall obtain all required street crossing permits from the appropriate authorities (City of Van Buren, Crawford County, and/or ARDOT). The Developer or Contractor shall pay all required fees and post any bonds required by the permitting authority.

- E. Repair of other paved areas shall be governed by the included specifications.

END OF SECTION 200 – SITE STANDARDS

SECTION 300 – WATER STANDARDS

1.01 SCOPE

- A. All water system improvements constructed within the service area of City of Van Buren Municipal Utilities (VBMU) shall be constructed in accordance with the standards and specifications described in this document.

1.02 GENERAL REQUIREMENTS AND DESIGN CRITERIA

- A. Developers are required to extend water service to their development at their own expense. Unless otherwise approved by VBMU, the Developer shall provide an individual water service to each lot in the development. VBMU will set individual water service meters at the property line, adjacent to public street rights-of-way, for all commercial, industrial, institutional, and single family structures. Additional meters may be requested for secondary uses such as lawn irrigation, etc.
- B. VBMU will set individual water service meters at the property line, adjacent to public street rights-of-way, for each unit in two-family (duplex), three-family (triplex), and four-family (quadplex) residential structures. VBMU approval of a single meter for multi-family units up to quadplexes will be considered on a case-by-case basis.
 - 1. VBMU will install individual service meters for each unit in multi-family structures (up to quadplexes) in a central location and in the order of the individual unit addresses, e.g., address 2402A, 2402B, 2402C and 2402D. The Developer is responsible for installing water service lines for multi-family structures to match each water meter in the correct order of the corresponding property addressing system. The Developer or Owner shall provide written verification to VBMU that water services are connected from the meter to the correct unit addresses and shall demonstrate compliance when requested by VBMU. Water service may be disconnected by VBMU until out of order service connections are corrected. See the *Corresponding Water Meter and Address Verification Form* in the Forms Section of the Design Standards or a copy can be obtained from the Director of Utilities.
- C. VBMU will set a single water service master meter at the property line, adjacent to public street rights-of-way, for multi-family structures larger than a four-family (quadplex). Individual meters for each unit in a development containing multiple two-family (duplex), three-family (triplex), or four-family (quadplex) residential structures on the same lot; or for a multi-family (apartment) structure, will be considered by VBMU on a case-by-case basis.
 - 1. When approved, VBMU will install individual service meters for each unit in multi-family structures larger than a four-family (quadplex) in a central location and in the order of the individual unit addresses, e.g., address 2402A, 2402B, 2402C and 2402D. The Developer is responsible for installing water service lines for multi-family structures to match each water meter in the correct order of the corresponding property addressing system. The Developer or Owner shall provide written verification to VBMU that water services are connected from the meters to the correct unit addresses and shall demonstrate compliance when requested by VBMU. Water service may be disconnected by VBMU until out of order service connections are corrected from the water meter to the unit being served. See the *Corresponding Water Meter and Address Verification Form* in the Forms Section of the Design Standards or a copy can be obtained from the Director of Utilities.

2. Where requests are approved for individual water service meters for multi-family structures or for multi-unit commercial or institutional facilities, and to avoid multiple service line crossings of a street or alley to connect to the public water line, an extension of the public water line to the property being served may be required. The Developer shall be responsible for the cost of installing approved individual service connections and the extension of public water lines to serve them.
3. Unless otherwise required by VBMU, all commercial, industrial and institutional fire protection systems will be unmetered. For single and multi-family residential structures with fire protection systems, meter requirements will be reviewed on a case-by-case basis. Connections to the fire protection system service for any other purposes are prohibited; these include but are not limited to irrigation systems, outside faucets, and flushing hydrants not suitable or approved for fire protection. Water service may be disconnected by VBMU until non-fire protection water connections are removed.
4. The Developer is responsible for determining all water flow requirements in accordance with state and local building codes, cross connection codes and ordinances and with the Arkansas Fire Prevention Code. The Developer is also responsible for the extension of water lines and appurtenances for connection to private fire protection systems, including the installation of backflow and cross connection features, heated enclosures, etc.
5. Minimum meter sizes shall be based on the following Table 3-1. Meter sizing for service line flows exceeding 600 GPM shall be determined based on site conditions and the requirements of the Developer’s Architect/Engineer.

Demand Range (GPM)	Water Meter Size
0 to 30	3/4-inch
31 to 50	1-inch
51 to 100	1-1/2-inch
101 to 160	2-inch
160 to 350	3-inch
350 to 600	4-inch

- D. Water lines for private fire protection systems shall comply with the Van Buren Cross Connection Control program and the Arkansas Department of Health’s *Policy for Cross-Connection Control for Fire Protection Systems*, latest edition. Fire Protection Sprinkler System plans shall be submitted to and approved by VBMU and the Arkansas Department of Health before installation begins.
- E. Water service shall include providing adequate domestic water flows as well as fire protection as defined in the City of Van Buren *Fire Protection Design Standards Ordinance*, latest edition.
- F. Water improvements shall be designed for the ultimate maximum projected residential service population that may be served by the hydraulic pressure zone downstream or therein supplied by the water improvements. Population projections shall be based on 20-year growth demographics as may be approved by VBMU and which are consistent with the current zoning designations. Consideration for water service demand shall be given to the maximum demand of non-population

(industrial, commercial, institutional, and fire protection) demands where such are identified and relevant.

- G. On subdivision or large-scale development water systems, water lines shall be extended through all the development to the property line so that future development(s) can tie on without disrupting the service to or property of any existing customers or property owners. For corner lots at the end of a development, the water line shall be extended to the nearest corner property line with provisions made for future extensions including necessary easements. Dead end lines shall be avoided whenever possible. All dead-end lines, if approved by VBMU, shall be constructed with approved blow off provisions and appurtenances to clean and flush the water line for maintenance purposes.
- H. Developments shall be connected to the existing water system supply network in at least two (2) locations such that there is more than one point of supply service. Exceptions to this requirement require prior approval by VBMU on a case-by-case basis.
- I. All new streets, as defined in the latest edition of the Van Buren Master Street Plan, shall include a new water line extension based on the following minimum line sizes:
 - 1. Local Street (residential zoning) – 6-inch diameter
 - 2. Local Street (commercial zoning) – 8-inch diameter
 - 3. Collector Street – 12-inch diameter
 - 4. Arterial Street – 12-inch diameter
- J. Water systems shall be designed wherever possible to include multiple paths to assure continuous supply and promote circulation. Valves shall be provided to allow for the isolation of water line segments without requiring the shutdown of the entire service area.
- K. Water systems shall be designed on an average usage of 100 gallons per capita per day. The population density used for the design shall be justified. Peak daily demand flows shall be 2.5 times the average daily flow, and peak hourly demand flows shall be 4.0 times the average daily flow. Water systems shall also have the capacity to provide a minimum of 1,500 GPM of fire flow at any public fire hydrant in the Development with consideration given to the local Insurance Service Office (ISO) rating and available fire flow storage in water storage reservoirs. The Engineer shall provide justification for proposed design flows for commercial, institutional, and industrial developments to VBMU for approval.
- L. All water lines with dead ends shall be installed with an upstream valve, one (1) full joint of pipe with a mechanical joint (MJ) restraining gland, concrete thrust blocking, an MJ cap with pipe restraint, and an above ground blow off assembly.
- M. All lines shall be designed to provide a minimum working pressure of 45 pounds per square inch (45 psi) at the meter, and under no circumstances shall the working pressure be less than 20 psi at any point in the system.
- N. Pipes in the water distribution system shall be sized such that velocities will be no greater than 5 feet per second (5 fps) during normal conditions. Velocities during fire flow conditions shall not exceed 18 feet per second (18 fps).
- O. The minimum sized distribution system piping that may be installed in residential areas is 6-inch diameter. Four-inch (4-inch) diameter line may be approved for cul-de-sacs and for other lines less than 300 feet in length that could not be reasonably expected to be extended in the future to provide service to adjacent properties and where a larger line is not needed to provide either fire

protection or adequate domestic flows. Requests or proposals for the installation of water lines smaller than 4 inches in diameter will be reviewed by VBMU on a case-by-case basis.

- P. The minimum sized line that may be installed in commercial and industrial areas is 8 inches in diameter. Requests or proposals for the installation of water lines smaller than 8 inches in diameter will be reviewed by VBMU on a case-by-case basis.
- Q. The City of Van Buren Municipal Utilities Water Master Plan, latest edition, has identified several locations that require larger diameter piping for system stability and performance. If the Master Plan, or a current VBMU or Engineer's review, has identified a larger line within the proposed development than is required to meet the local hydraulic requirements, it is required that the larger diameter line be installed as directed by the approved Master Plan or review. Exceptions to this requirement for developments less than two (2) acres shall be reviewed by VBMU on a case-by-case basis. In the event an exception is granted a dedicated public water line easement shall still be provided for the line required by the Master Plan or review.
- R. Water lines shall be placed on public streets either in the right-of-way or in an easement adjacent to the street, except that lines may go in an acceptable easement located between lots when there is no other reasonable way to access a line or provide for future service. Water line installations approved in an acceptable easement located between lots or buildings shall be constructed of cement lined ductile iron pipe.
- S. Water lines shall cross above sewer lines whenever possible, and they shall have at least 18 inches of vertical separation between the crown of the sewer line and the flowline of the water line. Crossings shall be as near to a 90-degree angle as possible. Exceptions to these requirements must comply with the current ADH requirements, be approved by VBMU, and will require a special, site specific design.
- T. Water lines shall have at least 10 feet of horizontal separation from sanitary sewer lines and 5 feet of horizontal separation from all other utilities unless otherwise specified by VBMU review.
- U. Water lines that are larger than 12 inches in diameter or more than 8 feet deep from the proposed finished grade shall be constructed of cement lined ductile iron pipe. All other lines may be constructed of either ductile iron or PVC pipe unless otherwise specified by VBMU review.
- V. All wetted components shall be NSF/ANSI 61 certified and meet the requirements of the current Safe Drinking Water Act and NSF/ANSI 372 standards as being lead free.
- W. Prior to acceptance by VBMU, all fire hydrants shall be tested by VBMU personnel or the Van Buren Fire Department for fire flow capacity.
- X. Water line valves located in paved streets, parking lots, driveways or under concrete sidewalks shall be constructed such that the valve box lid is flush with the finished elevation of the concrete or asphalt. Where typical water line construction details will not allow adjusting the valve box lid to be flush with pavements, etc., the relocation of the valve to an unrestricted location or the relocation of the paved or concreted area must be considered.
- Y. In order for the premises or development to be eligible for water service the public water distribution system must have excess capacity to accommodate the projected residential, commercial, institutional, and fire flow demands from the premises or development. This determination will be made by VBMU on a case-by-case basis following a review of the information submitted by the Developer. If the existing infrastructure does not have sufficient

capacity, VBMU may require that the Developer construct offsite improvements to provide the required capacity. The Developer shall be responsible for the cost of the required offsite improvements.

1.03 BELOW GRADE WATER STRUCTURES

- A. Vaults shall be sized to allow for the installation and removal of any equipment installed in the vault. VBMU shall be the sole judge the sufficiency of space to be provided on all sides of a piece of equipment necessary for access and maintenance.
- B. Below grade water structures shall be designed so that they have a gravity drain that discharges to daylight or, when approved by VBMU, they may have a drain sump and pump. Drainage discharge endpoints must be approved by the City of Van Buren Building Department. Gravity drains shall have a flap valve or duck bill check valve installed on the outlet to prevent material entering the vault from the drain. Vaults with electrical equipment that do not have a gravity drain shall have an approved permanent sump pump installed, and sump pumps may not discharge into the sanitary sewer collection system. It is the responsibility of the Developer and/or water customer served by the water meter to provide and maintain electric service at their expense for the operation of the sump pumps. Once installation is completed and accepted, VBMU will maintain all items in the vault including the sump pump; however, the electric service expense shall remain the responsibility of the customer.
- C. Vaults shall have a lockable aluminum hatch that covers the entire top of the vault. Vaults that are larger than available hatches shall have at least two (2) hatches with one (1) designed as a 3-foot by 3-foot (3' x 3') personnel access hatch and the second hatch sized for the largest piece of equipment in the vault but no smaller than the personnel access hatch. At a minimum, aluminum hatches shall have a load rating of 300 pounds per square foot (300 psf) and shall be the W series by Halliday Products or an approved equal.
- D. All vaults shall have an aluminum ladder with a retractable ladder extension for personnel access.
- E. Control valves and pressure control valves shall be appropriate for the application and shall be manufactured by Cla-Val, Bermad, or approved equal.
- F. Air release valves shall meet the requirements of AWWA C512. Air release valves shall be Clean Water Air Release Valves by Val-Matic Valve & Manufacturing Corp. or an approved equal.
- G. Potable water meters three (3) inches and larger shall be as provided by VBMU, after the Meter Fee is paid, with integral stainless steel strainer and be configured for touch read. Meter installations shall be reviewed and approved by VBMU on a case-by-case basis.

1.04 WATER STORAGE TANKS

- A. All proposed projects that include a water storage tank shall be reviewed by VBMU on a case-by-case basis. The tank contractor shall be a specialist in the design and construction of the selected style of tank and shall have built in its own name not less than 10 comparable tanks within the last five (5) years, all of which now are giving satisfactory service. The tank contractor shall have on its staff a full time Professional Engineer licensed in the State of Arkansas with not less than five (5) years of experience in the design and field construction of the selected style of tank, and who will be the responsible engineer in charge of the fabricated tank and foundation design. The Developer shall submit a letter giving VBMU a list of references of recent work. The tank

contractor shall be responsible for the design, manufacture, delivery, erection, painting, and testing of the water storage tank.

- B. Elevated water storage tanks shall have a welded carbon steel water containment vessel and may have either a welded steel or concrete support system. Elevated water storage tanks shall meet the requirements of AWWA D100 or D107, latest edition, depending on the design of the tank. The Developer is responsible for determining if FAA lighting or warning systems are required. The Developer is responsible for installing such systems, if required.
- C. Ground water storage tanks with operating capacities of 1,000,000 gallons and less shall be constructed of welded carbon steel. Ground water storage tanks with an operating volume greater than 1,000,000 gallons may be constructed of either welded carbon steel or precast, prestressed concrete. Welded carbon steel tanks shall meet the requirements of AWWA D100, latest edition; and precast, prestressed concrete tanks shall meet the requirements of AWWA D110, latest edition. Precast, prestressed concrete tanks shall be Type III, precast with a steel diaphragm, and shall be prestressed using a continuous, circumferential, wire winding. The use of circumferential tendon prestressing is not permitted.
- D. All welded carbon steel tanks shall be coated according to AWWA D102, latest edition. VBMU shall approve all colors. The interior and exterior coating system shall be installed by an experienced painting contractor certified by the manufacturer and acceptable to VBMU to install the coating system. The painting contractor shall have ten (10) years of experience in the water tank market and have completed similar size water tank projects each year for the last three (3) year and provide references for review by VBMU. Under their contractor license, the painting contractor should have classifications for sandblasting, special coating applications and above ground tanks. The coating system shall be installed according to the manufacturer's recommendations and include any required surface preparation. The painting contractor shall guarantee the coating work for a period of no less than 2 years and include the repair of any coating defects due to faulty workmanship or materials that may appear on the structure during this period. The paint manufacturer shall furnish an extended 15-year material warranty to VBMU for color and gloss retention for the exterior coating system in accordance with ASTM D2244, ASTM D523 (at 60 degrees F), and ASTM D4214.
- E. All tank coating systems shall meet the health effects requirements in the latest editions of NSF 61: *Drinking Water System Components – Health Effects* and NSF 600: *Health Effects Evaluation and Criteria in Drinking Water*. The tank coating system shall be similar or equal to the system listed below by Tnemec, Inc., and/or as approved by VBMU:
 - 1. Interior Coating
 - a. Welding – All weld repairs shall be performed prior to the application of the prime coat.
 - b. Caulk gaps and voids as required with Sika Flex 1A or equal caulk after finish coat has been applied. Fill any pits or voids with TNEMEC Series 215 Surfacing Epoxy (for potable water contact) after primer has been applied to substrate.
 - c. Prime Coat – Immediately after abrasive blasting and before any rusting occurs, apply one (1) coat of TNEMEC Series 91-H2O-HYDRO-ZINC to all bare steel surfaces with a dry film thickness of 2.5 to 3.5 mils.

- d. Stripe Coat – Following the prime coat, roller apply a coat of TNEMEC Series N140-15BL “Tank White” POTA-POX PLUS to all weld seams and heavily pitted areas with a dry film thickness of 2.0 to 3.0 mils.
 - e. Intermediate Coat – Apply one (1) complete coat of TNEMEC Series N140-39BL “Delft Blue” POTA-POX PLUS with a dry film thickness of 6.0 to 10.0 mils.
 - f. Finish Coat – Apply one (1) complete coat of TNEMEC Series N140-15BL “Tank White” POTA-POX PLUS with a dry film thickness of 6.0 to 10.0 mils.
2. Exterior Coating
- a. Prime Coat – Immediately after abrasive blasting and before any rusting occurs, apply one (1) coat of TNEMEC Series 91-H2O-HYDRO-ZINC to all bare steel surfaces with a dry film thickness of 2.5 to 3.5 mils.
 - b. Intermediate Coat – Apply one (1) complete coat of TNEMEC Series 73 ENDURA-SHIELD II with a dry film thickness of 2.0 to 3.0 mils. Color shall be as recommended by the paint Manufacturer, but it shall contrast in color to the finish coat.
 - c. Finish Coat – Apply one (1) coat of TNEMEC Series 700 HYDROFLON with a dry film thickness of 2.0 to 3.0 mils. The final coat color shall be selected by the Developer and approved by VBMU.
- F. Potable water tanks that serve a new pressure zone shall be sized to provide 24 hours of net effective storage plus the required fire flow storage for the entire area covered in that pressure zone. The capacity required shall be based on complete build out of the area covered by the pressure zone using the current zoning of that service area.
- G. All components other than the tank that will be exposed to weather shall be constructed of material that is resistant to corrosion and will not require surface protection throughout the expected life of the station. In general, these materials are stainless steel and aluminum. The use of fiberglass reinforced polyester (FRP) and UV Stabilized PVC for these applications will be reviewed by VBMU on a case-by-case basis.
- H. Water storage tanks shall include a tank mixing system to minimize water age and the stratification of water within the tank. The Engineer shall submit an analysis of the tank mixing system for review and approval by VBMU. The analysis shall include an evaluation of the potential for stratification in an unmixed tank, recommendations to prevent short-circuiting within the tank, and the rate of turnover and maximum mixing time with the proposed mixing system.
- I. All water storage tanks shall have separate inlet and outlet piping.
- J. Requirements for water level sensing, telemetry control of water storage tanks, and flow monitoring are defined in Section 500 – Electrical and Instrumentation Standards.

1.05 PUMP STATIONS

- A. Pump Stations shall be reviewed by VBMU for conformance with these standards, and its suitability for the proposed development on a case-by-case basis.

- B. The Developer must determine and submit the present value of the estimated operation and maintenance cost for the estimated service life of the pump station. The estimated service life shall be 20 years, and the following minimum assumptions shall be made when calculating life cycle costs:
1. Pump Station Construction Costs = Actual Cost
 2. Pump Station Routine O&M = 50 hours/year at \$40 per hour
 3. Effective Long Term Energy Costs = \$0.25/kW-hour
 4. Interest Rate = 5%
 5. Inflation Rate = 3%
 6. Replace Pumps in year 16
- C. Pump stations shall be designed entirely above grade and shall be constructed inside of a pump station building that is sized to house all the pumping, electrical, and instrumentation equipment with appropriate space provided for the maintenance of the equipment. All electrical gear shall be installed such that code required clearances are maintained.
- D. The building shall be air conditioned/heated with a mini-split heat pump. The building shall have aluminum doors similar or equal to the Flushline Series by Kawneer with appropriate frame, transom, security and panic hardware. The exterior building finish shall be single color split face masonry block construction. Exterior finishes (such as brick) and other architectural treatments will be considered on a case-by-case basis by VBMU. The material color for the exterior finishes shall be approved by VBMU and shall match the character of the surrounding construction. The interior shall be painted with a light, neutral color; and the coating system(s) shall be as recommended by the coatings manufacturer for the surface materials and anticipated environmental conditions. The roof shall be constructed in a hip configuration and be covered using a standing seam roofing system with metal trim. The roof shall have gutters and downspouts to collect water and direct it away from the perimeter of the building.
- E. The pump station shall be designed to operate on 480V, 60 Hz, 3 Phase power. Any deviation to this requirement will be reviewed for approval on a case-by-case basis by VBMU. See Section 500 – Electrical and Instrumentation Standards for additional requirements.
- F. All mounting hardware and appurtenances for piping and valves shall minimally be Type 304 stainless steel. Materials for piping, valves, hardware and appurtenances used with chemical feed systems shall be compatible for use with the chemical and approved by VBMU
- G. All components of the pump station that will be exposed to wet or damp environments shall be constructed of material that is resistant to corrosion and will not require surface protection throughout the expected life of the station. In general, these materials are stainless steel and aluminum. The use of fiberglass reinforced polyester (FRP) and UV Stabilized PVC for these applications will be reviewed by VBMU on a case-by-case basis.
- H. All interior piping connections will be with Class 150 or Class 300 flanges as required by the local pressure conditions.
- I. Each pump shall be equipped with a dedicated resilient wedge gate valve (isolation valve) on each side of the pump and a swing-type check valve on the discharge side of the pump. Gate valves shall be A-2360 or A-2361 Series by Mueller Water Products, Inc. or approved equal. Check valves shall be Swing Check, Swing-Flex, or Surge Buster series by Val-Matic Valve and Manufacturing Corp. or approved equal. Wafer style check valves are not allowed. The use of butterfly valves in place of gate valves will be reviewed by VBMU on a case-by-case basis.

- J. A surge analysis shall be performed on all pump stations. Surge tanks and/or surge anticipation valves shall be installed as recommended by the surge analysis.
- K. All pipe and fittings within the pump station shall be cement lined ductile iron with an exterior epoxy coating equal to 2 coats of N69-Color Hi-Build Epoxoline II (4-6 mils DFT per coat) by Tnemec or approved equal. All stainless steel hardware shall be protected from field applied epoxy.
- L. The pump station site shall have a security fence and the site shall be graded to drain away from the pump station structures. All areas inside the fence shall be surfaced with gravel, hot mix asphalt concrete, or Portland cement concrete.
- M. The pump station site shall be provided with an access drive to the nearest public road. The access drive shall have a stabilized gravel base and hot mix asphalt concrete or Portland cement concrete surface. If the slope of the access drive is more than 10%, the surface shall be designed and constructed in such a way to prevent pavement creep. The drive shall enter the public road at a curb cut and have a concrete apron.
- N. The pump station site shall be secured with a minimum 6-foot high, 9-gauge, galvanized chain link, climb proof fence with a 12-foot wide double gate and 3-foot wide personnel gate. Both gates shall be provided with a lockable hasp. All fencing shall be commercial grade, have galvanized steel posts and horizontal rails, and shall be constructed in accordance with the standard details. Other fence fabric materials (wood, etc.) will be reviewed by VBMU on a case-by-case basis.
- O. All proposed pump stations shall be equipped with a permanent, diesel-fueled standby generator large enough to run all pumps that operate during normal operating conditions and an automatic transfer switch that will initiate generator operation in the event of a power outage.
- P. All pump stations shall be equipped with an electromagnetic flow meter with remote mounted converter similar to Enviromag 2000 by Krohne, Inc. Meter sizing and manufacturer shall be reviewed by VBMU. All meters shall be installed per the manufacture's recommendation for optimum performance. Meters shall be installed in concrete vaults with full coverage aluminum hatches unless otherwise approved by VBMU.
- Q. Requirements for telemetry control of water pump stations and flow monitoring are defined in Section 500 – Electrical and Instrumentation Standards.

1.06 PUMPING EQUIPMENT

- A. Pump equipment for potable water pump stations shall be either vertical in-line multi-stage centrifugal pumps or horizontal split case pumps. Pump efficiencies shall be at least 75% unless approved by VBMU.
- B. All pump stations shall include a spare (standby) pump of the same size and capacity of each of the other pumps in that station. The standby pump(s) shall not be necessary for the normal operation of the pump station. This pump should be set to alternate normally with the other pumps, but in all cases, there should be a redundant pump in the event that a called pump fails to operate.
- C. Each pump shall have a separate, dedicated variable frequency drive (VFD).
- D. Pumping equipment shall be manufactured by Peerless or Fairbanks Morse. Pumping equipment from manufactures other than these will be reviewed by VBMU on a case-by-case basis.

- E. Pump warranty shall be provided by the pump manufacturer and shall warrant the units being supplied to VBMU to be free of defects in workmanship and materials for a period of five (5) years under normal use, operation, and service. The equipment shall be covered 100% for all required parts and labor for the first year and for 50% parts and labor for years two through five (2 - 5). The warranty period shall begin on the date of acceptance of the pump stations by VBMU. The warranty shall be in printed form and apply to all similar units.

1.07 DOCUMENTATION AND ACCEPTANCE

- A. The characteristics and operating conditions of the pump station, pumps, and tanks shall be provided in detail as part of the Engineer's design and submitted for approval by VBMU.
- B. Prior to installation, the Engineer shall provide copies of the Contractor's equipment submittals with the following information for each pump to VBMU for review:
 - 1. Pump capacity in gallons per minute
 - 2. Total dynamic head (TDH) and pump operating RPM
 - 3. Motor horsepower
 - 4. Motor RPM
 - 5. Motor voltage, phase, and cycle
 - 6. Make and model number
 - 7. Certified pump curves for the pumps being provided
- C. Pump Station acceptance will be based upon pump tests. The acceptable range is +10% and -5% of the reported pump capacity in GPM. Pump flows outside of the range will result in non-compliance with the standard, and the pump station will not be accepted.

1.08 FIRE PROTECTION

- A. The fire protection standards for the City of Van Buren are defined by the latest edition of the "Fire Protection Design Standards Ordinance" and the Arkansas Fire Prevention Code as applicable.
- B. When a private fire hydrant is required within the limits of a private development, the Developer is responsible for the installation and maintenance of the fire hydrant, piping lead and watch valve (as appropriate) from the tapping valve or main line connection to the private hydrant.

1.09 WATER SERVICES

- A. In all new developments where water lines are being installed, the Developer shall install all water taps with service saddle and tap, corporation stop, service line, curb stop, and meter box with setter in accordance with the specifications and standard details. In this situation, VBMU will waive the water tap fee and only require payment of a meter set (installation) fee from the Developer or property owner at the activation of the individual water service. The Developer or Builder are responsible for maintaining the meter box, lid and setter at proper grade and useful condition during the construction and building process.
- B. Water meters shall be placed or located on the street side of all lots. In no case shall water meters be placed at the rear of the lot or back property line, along the side of the lot, or in a location that is inaccessible for reading and maintenance by VBMU. Unless otherwise approved by VBMU, water meter boxes and vaults shall not be installed within concrete or asphalt pavement, including driveways and sidewalks.

- C. Each lot in a development shall be served by a dedicated meter in accordance with Subsection 1.02 above.
- D. All water service taps shall only be installed on public potable water distribution lines.
- E. Water service locations shall be marked on the curb where the water service crosses the curb. The mark shall be stamped or engraved into the curb.
- F. When a private water service line is to be installed across the private portion of a lot, parcel, tract or other property not being served by the new water meter, the Developer or property owner shall provide proof of easement or written permission from the adjacent property owner before a water service connection and meter will be installed.

1.10 BACKFLOW PREVENTION

- A. The City of Van Buren public water distribution system shall be protected from the possibility of backflow contamination by the installation and use of an approved backflow prevention assembly in accordance with the City of Van Buren Municipal Utilities Cross Connection Control program, all Arkansas Department of Health rules and regulations governing cross-connection control and backflow prevention, and the Arkansas State Plumbing Code, latest edition.
- B. VBMU shall review and approve all proposed containment backflow prevention assemblies prior to installation.

1.11 PROPERTY DEDICATION

- A. The Developer shall provide a 15-foot wide public water line utility easement for all water lines buried up to 7 feet deep. Easement widths required for locations where lines are more than 7 feet deep or installed between lots or buildings shall be determined on a case-by-case basis, and VBMU reserves the right to require the dedication of easements with widths greater than 15 feet. Water lines shall be installed as close to the center of the easement as possible.
- B. The Developer shall provide additional easement width beyond the normal water line easement described above for the installation of vaults for control valves, pressure reducing valves, water meters (typically 3-inch and larger), and other underground structures. Dedication of additional easement width or other property dedication shall be determined on a case-by-case basis and as required by VBMU.
- C. The Developer shall provide a minimum 50-foot by 50-foot (50' x 50') deeded lot for all pump stations and elevated tanks less than 250,000 gallons. The lot shall accommodate a minimum, unobstructed access easement width of 15 feet around the structure for maintenance purposes, coating of structures, etc. The locations and sizes of properties for elevated tanks greater than 250,000 gallons and all ground storage tanks shall be approved on a case-by-case basis. Ownership of the property must be transferred to the VBMU by warranty deed and not merely by the platting of the pump station or tank lot within a larger subdivision. If the deeded property is not continuous with public street right-of-way, the Developer shall also provide a minimum 15-foot wide access easement across private property. Dedication of additional easement width or other property dedication shall be determined on a case-by-case basis and as required by VBMU.
- D. If undeveloped property exists beyond the limits of the development, additional water easements may be required to be dedicated to VBMU to provide for future service access.

END OF SECTION 300 – WATER STANDARDS

SECTION 400 – SANITARY SEWER STANDARDS

1.01 SCOPE

- A. All sanitary sewer system improvements constructed within the service area of City of Van Buren Municipal Utilities (VBMU) shall be constructed in accordance with the standards and specifications described in this document.

1.02 GENERAL REQUIREMENTS AND DESIGN CRITERIA

- A. Developers are required to extend sanitary sewer service to their development at their own expense. Unless otherwise approved by VBMU and the City of Van Buren Plumbing Inspector, the Developer shall provide an individual sewer service to each lot in the development. The Developer shall install a service connection, service line, and watertight cap for each lot. Service lines shall be extended from the sewer main to the property line, right-of-way, or easement boundary.
- B. Sewer improvements shall be designed for the ultimate tributary population. For the purpose of projecting wastewater collection system expansion, the tributary population shall be estimated at 80% of the maximum population for the land upstream of the proposed development as defined by the drainage basins delineated in the latest edition of the City of Van Buren Municipal Utilities Sewer Master Plan. Population densities shall be based on a 20-year projection and shall be consistent with the current zoning designations for the affected properties. Consideration shall be given to the maximum demand of non-population (industrial, commercial, and institutional) demands where such are expected. Sewer lines shall be extended to the edge of any development where future development might be expected to connect. For corner lots at the end of a development, the public sewer line shall be extended to the nearest corner property line with provisions made for future extensions including necessary easements.
- C. New residential sewer system design shall be based on an average flow of 100 gallons per-capita-per-day (100 gal/person-day) and a minimum of 2.6 persons-per-residence. New commercial and industrial sewer systems shall be designed based on the peak flows anticipated by the Developer but should not be less than 5,000 gallons-per-acre-per-day. The Developer shall submit average daily and peak daily flow rates to VBMU for review and approval.
- D. The peak hourly wastewater design flow for a residential development shall be 3.0 times the average daily flow.
- E. The Engineer shall provide justification for proposed average daily design flows for commercial, institutional, and industrial developments to VBMU for approval. The peaking factors for commercial, institutional, and industrial developments shall range from 2.5 to 5.0. Proposed peaking factors shall be justified by the Engineer and approved by VBMU.
- F. VBMU reserves the right to require pretreatment of commercial and industrial waste streams before the discharge of sewage into the public sewer collection system pursuant to the City of Van Buren Municipal Utilities Pretreatment Program.
- G. Collector sewers shall have peak flow capacities based on the sewer flowing two-thirds (2/3) full. Trunk sewers (18 inch diameter and larger) shall have peak flow capacities based on flowing 90% full with no surcharging.

- H. The required diameter of gravity sewers shall be determined by Manning’s formula using a roughness coefficient, “n” of 0.013 or the pipe manufacturer’s recommendation, whichever is greater. The minimum pipe diameter for gravity sewers shall be 8 inches.
- I. The City of Van Buren Municipal Utilities Sewer Master Plan, latest edition, and the Van Buren Sanitary Sewer System Evaluation Survey identify several locations that require larger diameter lines for capacity. If the Master Plan or VBMU review identifies a larger sewer line within the proposed development than is required to meet the local hydraulic requirements, then the larger diameter line must be installed.
- J. The minimum pipe diameter for sewer force mains shall be 4 inches.
- K. All gravity flow sanitary sewers shall be designed and constructed to provide a minimum velocity of 2 feet per second when flowing full. The slope of the sewer pipe shall be such that these minimum velocity requirements are attained. The minimum allowable slopes required for design are listed in the table below.

Nominal Sewer Size	Minimum Slope in Feet per 100 Feet
8-inch	0.40
10-inch	0.28
12-inch	0.22
14-inch	0.17
15-inch	0.15
16-inch	0.14
18-inch	0.12
21-inch	0.10
24-inch	0.08
30-inch	0.058
36-inch	0.046
42-inch	0.037

- L. Sewers installed with drainage slopes greater than 20% shall be anchored securely with concrete, or equal, with anchors spaced as follows:
 - 1. Not over 36 feet center to center on grades of 20 percent to 35 percent (20% - 35%)
 - 2. Not over 24 feet center to center on grades of 35 percent to 50 percent (35% - 50%)
 - 3. Not over 16 feet center to center on grades 50 percent and over ($\geq 50\%$)
- M. Sewers shall be laid in a straight alignment between manholes.
- N. Sewer lines and force mains larger than 12 inches in diameter, more than 8 feet below finished grade, and installations approved in an acceptable easement located between lots or buildings shall be constructed of cement lined ductile iron pipe. All other sewer lines may be constructed of either cement lined ductile iron pipe or PVC pipe unless otherwise specified by VBMU. The use of epoxy lined ductile iron pipe may be required by VBMU in locations where high concentrations of corrosive gases may occur. PVC pipe for force mains shall conform to AWWA C900, and PVC pipe for gravity sewer lines shall conform to ASTM D3034 SDR 35 or SDR 26. All PVC pipe shall have a Mega-Stop Series 5000 PVC Bell Protection System by EBAA Iron or approved equal

installed on all joints to prevent the over-insertion of spigots. Justified variances from this standard will be considered on a case-by-case basis by VBMU.

- O. Air release, air/vacuum, and/or combination air valves shall be installed on all force mains at high points and other locations as necessary to prevent the accumulation of air in the line or the collapse of the line due to negative pressure. Valves shall be sized and located in accordance with the manufacturer's recommendations for the force main's peak operating conditions.
- P. Sewer lines shall cross below water lines whenever possible, and they shall have at least 18 inches of vertical separation between the crown of the sewer line and the flowline of the water line. Crossings shall be as near to a 90-degree angle as possible. Exceptions to these requirements must be approved by ADH and VBMU and will require a special, site specific design.
- Q. Sewer lines shall have at least 10 feet of horizontal separation from water lines and 5 feet of horizontal separation from all other utilities. Exceptions to this requirement shall be approved by ADH and VBMU.
- R. In order for the premises or development to be eligible for sewer service the collection system must have excess capacity to accommodate the projected sewage flows from the premises or development. This determination will be made by VBMU on a case-by-case basis following a review of the information submitted by the Developer. If the existing infrastructure does not have sufficient capacity VBMU may require that the Developer, at their expense, construct offsite improvements to provide the required capacity.

1.03 SEWER STRUCTURES

- A. Manholes shall be installed at the terminal end of each gravity line; at all changes in grade, size, materials, or alignment; at all sewer intersections; and at intervals not to exceed 400 linear feet. Deviations to the maximum manhole spacing may be approved by VBMU on a case-by-case basis but in no circumstances will the interval between manholes exceed 500 feet.
- B. Manholes shall be located such that they are readily accessible to sewer cleaning equipment. Access shall include an all-weather driving surface with a minimum width of 10 feet. A 10-foot wide double gate shall be provided at all fence crossings where manhole access is required. Sewer mains located in easements behind structures without a dedicated, paved alley shall have the manholes located adjacent to the nearest street right-of-way.
- C. When changing alignment or pipe size, the invert of the downstream pipe should be located to maintain the energy gradient line.
- D. Connections between sewer lines shall be installed at such elevations that the higher flow sewer line will not cause backups in the lower flow sewer line.
- E. Design and construct manholes to be installed in unpaved areas such that the top of the casting is a minimum of 3 inches and a maximum of 5 inches above the finished grade. Provide positive drainage away from the manhole. Manholes located in paved streets, parking lots, driveways or under concrete sidewalks shall be constructed such that the manhole lid is flush with the finished elevation of the concrete or asphalt. Where typical manhole construction details will not allow adjusting the manhole rim to be flush with pavements, etc., the relocation of the manhole to an unrestricted location or the relocation of the paved or concreted area must be considered.

- F. Manholes constructed within a 100-year floodplain or within a designated flood prone area shall be constructed such that the rim elevation is a minimum of 2 feet above the base flood elevation or be constructed with a watertight frame and cover assembly. If the base flood level is not established for flood prone areas, watertight frame and covers are required. Watertight frame and cover assemblies within 2 feet of finished grade shall be *Campression* style (cam-lock) by East Jordan Iron Works or approved equal. Watertight frame and cover assemblies more than 2 feet above finished grade shall be *Revolution* style (pivoting lid) by East Jordan Iron Works or approved equal.
- G. Manhole frame and cover assemblies shall have a minimum clear opening of 22 inches. Frame and cover assemblies for manholes with connecting pipes greater than 18 inches in diameter shall have a clear opening of at least 30 inches. Manhole frame and cover assemblies that are within 6 inches of finished grade shall have a heavy duty load rating.
- H. Manhole covers shall not have any hole which would allow water to enter the sanitary sewer collection system. All pick holes shall be either a closed style or a pick slot. Open pick holes, pick bars, and drop handles are not allowed.
- I. Outside drop pipe connections shall be provided for all sanitary sewers entering a manhole at an elevation greater than 24 inches above the invert of the manhole. Manhole drops shall be constructed in accordance with the specifications and standard details.

1.04 SEWER SERVICES

- A. Sewer services shall be constructed in accordance with the latest edition of the Arkansas State Plumbing Code, as adopted by the City of Van Buren. Sewer service piping wyes shall be Romac Industries #218-F4804U or approved equal.
- B. Building sewers installed for future connections shall be terminated at the right-of-way or easement and plugged to ensure 100 percent water tightness. Mark wyes and/or service line terminations for future connections using nylon or polypropylene rope and a 1/2 inch x 4 foot rebar or fence tee-post. The location rope shall extend from the wye or service line termination point to the surface of the ground and the marker post.
- C. Sewer service locations shall be marked on the curb where the sewer service crosses the curb. The mark shall be stamped or engraved into the curb.
- D. When a private sewer service is to be installed across the private portion of a lot, parcel, tract or other property not being served by the new sewer service, the Developer or property owner shall provide proof of easement or written permission from the adjacent property owner before a sewer service connection will be installed.

1.05 SEWAGE PUMP STATIONS

- A. Construction of a sanitary sewage pump station shall not proceed until an economic analysis or hydraulic analysis prove to the satisfaction of VBMU that the pump station has a lower 20-year life cycle cost than extending gravity sewer. The Developer must determine and submit the present value of the alternatives and must use the following minimum assumptions when calculating life cycle costs:
 - 1. Pump Station Construction Costs = Actual Cost
 - 2. Pump Station Routine O&M = 50 hours/year at \$40 per hour
 - 3. Effective Long Term Energy Costs = \$0.25/kW-hour

4. Interest Rate = 5%
 5. Inflation Rate = 3%
 6. Replace Pumps in year 11
- B. Only if a pump station is more cost effective or is the only hydraulically feasible option, will a pump station be accepted by VBMU.
 - C. Pump stations shall be reviewed by VBMU for conformance with these standards, and its suitability for the proposed development on a case-by-case basis.
 - D. Pump stations shall have wet pit submersible pumps and shall be constructed with a cast-in-place concrete wet well. Pump stations shall have a separate wet well and valve vault and shall have a building for the electrical equipment. Precast concrete and fiberglass wet wells will be considered by VBMU on a case-by-case basis.
 - E. Wet wells shall be sized to support a minimum of two (2) pumps including all necessary piping and rails. An aluminum hatch shall be cast into the deck of the wet well and sized to allow for the removal of the pumps.
 - F. Each pump shall be equipped with a dedicated resilient wedge gate valve and a swing-type check valve. Gate valves shall be A-2360 or A-2361 Series by Mueller Water Products, Inc. or approved equal. Check valves shall be Swing Check, Swing-Flex, or SurgeBuster series by Val-Matic Valve and Manufacturing Corp. or approved equal. Wafer style check valves are not allowed.
 - G. Valve vaults shall be sized to incorporate all required valves and fittings as well as provide at least 18-inches of clearance on each side of each appurtenance. An aluminum hatch shall be cast into the deck of the valve vault and sized to cover the entire area of the vault. Variations to the requirement shall be reviewed by VBMU on a case-by-case basis.
 - H. The pump station shall be designed to operate on 480V, 60 Hz, 3 Phase power. Any deviations to this requirement will be reviewed by VBMU on a case-by-case basis. See Section 500 – Electrical and Instrumentation Standards for additional requirements.
 - I. All mounting hardware and appurtenances for piping and valves shall minimally be Type 316 stainless steel. Materials for piping, valves, hardware and appurtenances used with chemical feed systems shall be compatible for use with the chemical and approved by VBMU.
 - J. All components of the pump station that will be exposed to weather shall be constructed of material that is resistant to corrosion and will not require surface protection throughout the expected life of the station. In general, these materials are stainless steel and aluminum. The use of fiberglass reinforced polyester (FRP) and UV Stabilized PVC for these applications will be reviewed by VBMU on a case-by-case basis.
 - K. All pressure piping within the pump station site shall be ductile iron and shall be lined with Protecto 401 epoxy or approved equal.
 - L. All valves and ductile iron pipe and fittings shall have an exterior epoxy coating. All ductile iron piping installed in the wet well, dry well, or valve pit shall have a two-coat exterior epoxy similar or equal to 435 Perma-Glaze (15-20 mils total DFT) by Tnemec or Sher-Glass FF (8-12 mils DFT per coat). Stainless steel hardware shall be protected from field applied epoxy.

- M. The pump station site shall have an all-weather surface within a security fence and shall be graded to drain away from the pump station structures. All areas inside the fence shall be surfaced with gravel, hot mix asphalt concrete, or Portland cement concrete.
- N. The pump station site shall be provided with an access drive to the nearest public road. The access drive shall be an all-weather surface with a stabilized gravel base and hot mix asphalt concrete or Portland cement concrete surface. If the slope of the access drive is more than 10%, the surface shall be designed and constructed in such a way to prevent pavement creep. The drive shall enter the public road at a curb cut and have a concrete driveway apron.
- O. The pump station site shall be secured with a minimum 6-foot high, 9 gauge, galvanized chain link, climb proof, fence with a 12-foot wide double gate and 3-foot wide personnel gate. Both gates shall be provided with a lockable hasp. All fencing shall be commercial grade, have galvanized steel posts and horizontal rails, and shall be constructed in accordance with the standard details. Other fence fabric (wood, etc.) materials will be considered by VBMU on a case-by-case basis.
- P. All pump stations shall have a building for housing the pump station electrical equipment. The pump station shall have a minimum interior dimension of 6'-8" by 6'-8". The building shall be sized to house all electrical and instrumentation equipment with spacing compliant with the appropriate electrical codes. The electrical building shall be air conditioned/heated with a mini-split heat pump. The building shall have an aluminum door similar or equal to the Flushline Series by Kawneer with appropriate frame, transom, security and panic hardware. The exterior building finish shall be single color split face masonry block construction. Exterior finishes (such as brick) and other architectural treatments will be considered on a case-by-case basis by VBMU. The material color for the exterior finishes shall be approved by VBMU and shall match the character of the surrounding construction. The interior shall be painted with a light, neutral color; and the coating system(s) shall be as recommended by the coatings manufacturer for the surface materials and anticipated environmental conditions. The roof shall be constructed in a hip configuration and be covered using a standing seam roofing system with metal trim. The roof shall have gutters and downspouts to collect water and direct it away from the perimeter of the building.
- Q. All proposed pump stations shall be equipped with a permanent, diesel-fueled standby generator large enough to run all pumps that operate during normal operating conditions and an automatic transfer switch that will initiate generator operation in the event of a power outage.
- R. All pump stations shall be equipped with an electromagnetic flow meter with remote mounted converter similar to Enviromag 2000 by Krohne, Inc. Meter sizing and manufacturer shall be reviewed by VBMU. All meters shall be installed per the manufacture's recommendation for optimum performance. Meters shall be installed in concrete vaults with full coverage aluminum hatches unless otherwise approved by VBMU.
- S. Requirements for wet well level sensing, telemetry control of sewage pump stations, and flow monitoring are defined in Section 500 – Electrical and Instrumentation Standards.
- T. Requirements for installation of odor control equipment by the Developer, for new pump stations and developments near existing pump stations, will be evaluated and determined by VBMU on a case-by-case basis. When required, odor control equipment shall be minimally sized for a capacity of 300 cubic-feet-per-minute (300 cfm) with a gas removal efficiency of at least 99%. Odor control equipment shall be an activated carbon adsorption system, similar and equal to the PureAir Filtration System, Model DS-300. VBMU shall be the final approval authority on equipment manufacturers or alternative odor treatment systems. The Developer shall be responsible for all costs associated with installing the odor control system.

1.06 PUMP STATION SIZING

- A. The pump station wet well shall be designed to provide a minimum of 5 feet of storage below the lowest inlet. The wet well shall also meet the following criteria:
 - 1. All pump-off elevations shall be set at the pump manufacturer's recommended level but no less than 1.5 feet from the bottom of the wet well.
 - 2. Pump starting and stopping elevations shall be set such that the pumps have a minimum 15 minute cycle time between starts based on average daily flow.
 - 3. The lag pump-on shall be set a minimum of 6 inches above the lead pump-on and a minimum of 12 inches below the lowest inlet pipe invert.
 - 4. The high water alarm shall be set a minimum of 6 inches above the lag pump-on and a minimum of 6 inches below the lowest inlet pipe invert.
 - 5. All level control elevations shall be set below the lowest inlet pipe invert.
- B. Wet wells shall have a minimum interior horizontal dimension of 6 feet.

1.07 PUMPING EQUIPMENT

- A. Pumps shall be of the submersible type for handling raw, unscreened sewage and shall have a minimum capacity of 100 GPM. Pump efficiencies shall be at least 60% unless approved by VBMU.
- B. All pump stations shall include a spare (standby) pump of the same size and capacity of each of the other pumps in that station. The standby pump(s) shall not be necessary for the normal operation of the pump station. This pump should be set to alternate normally with the other pumps, but in all cases, there should be a redundant pump in the event that a called pump fails to operate.
- C. Pump volute, motor, and seal housing are to be high quality gray cast iron. Impeller shall be either cast iron, cast bronze, or hard iron of a non-clog design capable of handling 3-inch (minimum) spherical solids, fibrous materials, heavy sludge, and other matter found in normal sewage applications. The impeller shall have pump-out vanes on the back shroud of the impeller to keep pumped material away from the seal area and increase operating life. Impeller shall either slip fit or taper fit with key to securely lock the impeller to the drive shaft. The pump volute shall be fit with a replaceable wear ring to minimize wear on the impeller and help achieve longer balanced life. All fasteners shall be stainless steel.
- D. Each pump shall have a separate, dedicated variable frequency drive (VFD).
- E. Pumping equipment shall be manufactured by Flygt, Wilo, Gorman Rupp, or approved equal. Pumping equipment from manufacturers other than these will be reviewed by VBMU on a case-by-case basis.
- F. All mating surfaces where watertight sealing is required shall be machined and fitted with nitrile rubber O-rings. Sealing shall be accomplished when metal to metal contact is made, resulting in a controlled compression of the rubber O-rings without requirement of a specific torque limit.

- G. The pump shall be provided with a mechanical rotating shaft seal system running in an oil reservoir having separate, constantly lubricated lapped seal faces. The lower seal unit between the pump and oil chamber shall consist of one (1) stationary seat and one (1) rotating ring held in place by its own spring. The lower seal shall be removable without disassembling the seal chamber. The upper seal between the motor and seal chamber shall be of the same design with its own spring system. The seals shall require neither maintenance nor adjustment but shall be easily inspected and replaceable. The shaft sealing system shall be capable of operating submerged to pressures equivalent to 200 feet. No seal damage shall result from operating the pump unit out of its liquid environment. The seal system shall not rely upon the pumped media for lubrication.
- H. The seal chamber shall be equipped with a seal failure sensor probe that will sense water intrusion through the lower seal. This sensor is to be connected to an alarm in the control panel to indicate lower seal failure.
- I. The stator winding, rotor, and bearings shall be mounted in a sealed, submersible type housing. Insulation utilized in the stator windings shall be Class F with a maximum temperature capability of 155° C (311° F). Motor housing shall be filled with a high dielectric oil to give superior heat transfer and allow the bearing to run in a clean, well lubricated environment; or the housing shall be air filled with grease lubricated bearings. The pump and motor are to be specifically designed so that they may be operated partially or completely submerged in the liquid being pumped. The pump shall not require cooling water jackets. Stator shall be securely held in place with a removable end ring and threaded fasteners so that it may be easily removed in the field without the use of heat or press. Shaft shall be stainless steel and supported by ball bearings. Motor shall be provided with heat sensing units attached to the motor windings which shall be connected to the control panel to shut down the pump if overheating occurs.
- J. Pump cable shall be suitable for submersible pump applications, and this shall be indicated by a code or legend permanently embossed on the cable. Cable sizing shall conform to NEC specifications for pump motors and shall be of adequate size to allow motor voltage conversion without replacing the cable. Cable of the proper length shall be provided to eliminate the need for splices or junction boxes between the pump and service disconnect.
- K. The pump mount base shall include adjustable guide rail supports and a discharge connection with a 125-lb standard flange. The base and discharge piping shall be permanently mounted in place using stainless steel anchors.
- L. A rail system shall be provided for easy removal of the pump and motor assembly for inspection and service. The system shall not require entry into the wet well to remove the pump and motor assembly. Two (2) rails of at least 2-inch stainless steel pipe shall be provided for each pump.
- M. The pumps shall be equipped with sliding brackets or rail guides. The pumps shall also be equipped with a stainless steel lifting chain or other approved pump removal system. The installed pump removal equipment and methods must be satisfactorily demonstrated to the VBMU prior to acceptance.
- N. The rails and rail guides shall function to allow the complete weight of the pumping unit to be lifted on dead center without binding and stressing the pump housing. The rail system shall function to automatically align the pumping unit to the discharge connection by a simple downward movement of the pump. No twisting or angle approach will be considered acceptable. The actual sealing of the discharge interface shall be metal-to-metal contact.

- O. Pump warranty shall be provided by the pump manufacturer and shall warrant the units being supplied to VBMU against defects in workmanship and materials for a period of five (5) years under normal use, operation, and service. The equipment shall be covered 100% for all required parts and labor for the first year and for 50% parts and labor for years two through five (2 - 5). The warranty period shall begin on the date of acceptance of the pump stations by VBMU. The warranty shall be in printed form and apply to all similar units.

1.08 PROPERTY DEDICATION

- A. The Developer shall provide a 15-foot sewer line utility easement for all sewer lines buried up to 7 feet deep. Easement requirements for locations where sewer lines are more than 7 feet deep or installed between lots or buildings shall be determined on a case-by-case basis and as required by VBMU. All sanitary sewers shall be centered in the easement unless otherwise approved or directed by VBMU. Where sanitary sewers are constructed in the public right-of-way, the easement shall extend the distance outside the right-of-way necessary to provide the required easement width. Dedication of additional easement width or other property dedication shall be determined on a case-by-case basis and as required by VBMU.
- B. The Developer shall provide a minimum 50-foot by 50-foot (50' x 50') of deeded lot for all submersible pump stations with wet wells up to 20 feet deep. The lot shall accommodate a minimum, unobstructed access easement width of 15 feet around the structure for maintenance purposes, coating of structures, etc. Lot size requirements for pump stations with wet wells greater than 20 feet deep will be considered by VBMU on a case-by-case basis. Ownership of the property must be transferred to the VBMU by warranty deed and not merely by platting of the pump station lot within a larger subdivision. If the deeded property is not continuous with a public street right-of-way, the Developer shall also provide a minimum 15-foot wide access easement across private property. Dedication of additional easement width or other property dedication shall be determined on a case-by-case basis and as required by VBMU.
- C. If undeveloped property exists beyond the limits of the development, additional sanitary sewer easements may be required to be dedicated to VBMU to provide for future service access.

1.09 DOCUMENTATION AND ACCEPTANCE

- A. The characteristics and operating conditions of the pump station and pumps shall be provided in detail as part of the Engineer's design and submitted for approval to VBMU.
- B. Prior to installation, the Engineer shall provide copies of the Contractor's equipment submittals with the following information for each pump to VBMU for review:
 - 1. Pump capacity in gallons-per-minute (GPM)
 - 2. Total dynamic head (TDH) and pump operating speed (RPM)
 - 3. Motor horsepower (HP)
 - 4. Motor speed (RPM)
 - 5. Motor voltage, phase, and cycle
 - 6. Make and model number
 - 7. Certified pump curves for the pumps to be provided
- C. Pump Station acceptance will be based upon pump drawdown tests. The acceptable range is +10% and -5% of the reported pump capacity in GPM. Pump flows outside of the range will result in non-compliance with the standard, and the pump station will not be accepted.

1.10 PRIVATE SEWAGE PUMP STATIONS

- A. Private sewage pump stations may be constructed on private property only in situations where the property cannot be served by gravity sewer. Private pump stations must be constructed entirely on the property to be served and may not serve multiple properties or lots. Multi-family housing, multi-unit commercial plazas, and similar sized structures may utilize a single, private sewage pump station to serve all units, but the pump station must be operated and maintained by the owner or manager of the property. Private pump station force mains shall only discharge into gravity sewer manholes.
- B. Private sewage pump stations and force mains shall be constructed in accordance with Arkansas Department of Health and Arkansas Department of Environmental Quality Standards. All private sewer systems shall be reviewed and approved by the Arkansas Department of Health's Engineering and Plumbing Divisions as appropriate.
- C. Maintenance of private sewage pump stations and force mains is the responsibility of the property owner. In cases where public health and safety are threatened, VBMU reserves the right to discontinue providing a service connection for private sewage pump stations.
- D. Owners of privately owned pump stations serving commercial, industrial, institutional, or multifamily complexes shall provide and maintain signage that identifies the current owner and provide a 24 hour-per-day, 7 days-a-week emergency contact telephone number. The signage shall be mounted such that it is visible from an adjacent public street.
- E. Owners of private sewage pump stations shall complete a *Sewer Facility Operation and Maintenance Agreement* that links ownership and maintenance responsibility of the private sewage pump stations with ownership of the property. A copy of the Agreement form is included in the Forms Section of these Design Standards or can be obtained from the Director of Utilities. The Sewer Facility Operation and Maintenance Agreement shall be filed with the Crawford County Circuit Clerk, and a copy of the filed document with filing marks shall be submitted to VBMU.

END OF SECTION 400 – SANITARY SEWER STANDARDS

SECTION 500 – ELECTRICAL AND INSTRUMENTATION STANDARDS

1.01 SCOPE

- A. All electrical and instrumentation systems for the operation of water and wastewater equipment within the service area of City of Van Buren Municipal Utilities (VBMU) shall be constructed to the standards and specifications described in this document.

1.02 GENERAL REQUIREMENTS

- A. All costs associated with providing electrical service from the electric utility to the service entrance shall be the responsibility of the Developer. The Developer is required to coordinate all activities to provide the service with the electric utility.
- B. Pump stations shall utilize 480V, 3 Phase, 60Hz electrical service. Any deviation to this requirement shall be reviewed by VBMU on a case-by-case basis.
- C. Any pump station that is approved for 240V, 1 Phase, 60Hz electrical service shall utilize Variable Frequency Drives (VFD) in the design that accept single phase power input and produce three phase power output, allowing use of three phase pumps in the pump station. No single-phase pumps and associated start/run capacitors, start relays, and single phase starters shall be allowed.
- D. 480V, 3 Phase, 60Hz electrical services 200A or greater shall be supplied by pad-mounted utility transformer with electrical metering at the transformer. Any deviation to this requirement shall be reviewed by VBMU on a case-by-case basis, typically when flood plain issues would require a pole mounted transformer.
- E. 480V, 3 Phase, 60Hz electrical services less than 200A may be served by pole-mounted transformers. The metering point for the service shall be mounted on the electrical building.
- F. Grounding shall be installed according to National Electric Code.

1.03 EMERGENCY STANDBY POWER

- A. All pump stations shall be supplied with an emergency standby power generator and automatic transfer switch, sized to properly accommodate starting of electrical loads and building services without a voltage dip greater than 25%.
- B. The emergency standby power generator shall be powered by diesel fuel. Any deviation to this requirement shall be considered on a case-by-case basis by VBMU.
- C. The generator shall be equipped with a cold weather starting package, including engine block heater with recirculating coolant pump, battery warmer, and automatic battery charger.
- D. The generator shall be provided with a main circuit breaker, sized by the generator manufacturer in accordance with UL guidelines.
- E. The generator shall be equipped with an outdoor sound attenuated weatherproof enclosure.

- F. The generator shall be equipped with a fuel tank sized to hold a minimum available volume of one (1) day's operation of fuel with the generator running continually at full load.
- G. The standby power system shall include an automatic transfer switch (ATS), preferably mounted inside the electrical building. The standby power system shall also include a three-way manual transfer switch (3MTS) that allows the connection of a towable generator set in the event of failure to the permanent standby generator. The 3MTS shall be installed between the incoming utility short circuit protection and the ATS. The 3MTS shall also allow the connection of a load bank for testing of the standby generator without cabling changes. The 3MTS shall include cam lock connectors. Locations approved by variance without a 3MTS shall use a service entrance rated ATS and shall power up the entire facility when the generator is in use. The service entrance device in the ATS shall be a circuit breaker connected to utility power. The ATS switch shall be a separate contactor device. ATS which use a moving mechanism to turn off the utility service breaker are not allowed.
- H. The ATS shall have programmable operating set points for custom setup at each site based on operating conditions.
- I. The ATS shall have a programmable generator exerciser that allows loaded or unloaded testing of the generator. The exerciser time shall be programmable for any time of day of the week, with 15 minute exerciser incremental duration.
- J. The ATS and generator system shall be capable of annunciating faults and operating status to the local telemetry system through discrete four (4) Form C discrete outputs. Outputs shall be available for Generator Running, Generator Alarm, ATS in Utility, and ATS in Emergency.

1.04 ELECTRICAL EQUIPMENT

- A. All pumps shall be operated by Variable Frequency Drives (VFD).
- B. Pump VFDs shall be installed in Motor Control Centers (MCC). Any deviation to this requirement will be reviewed by VBMU on a case-by-case basis.
- C. Each pump VFD shall be provided with a Hand-Off-Auto selector switch to allow control by the telemetry system. In Auto position, the telemetry pump call and 4-20mA speed reference shall operate the pump. In Hand position, a switch contact shall call the pump to run and a local 0-10VDC potentiometer shall provide speed reference to the pump. Hand position shall be capable of operating the pump regardless of the status of the telemetry system. Off position prevents the pump from operation.
- D. Water pump stations shall be allowed to operate from a VFD only setup.
- E. Wastewater pump stations shall be required to have an isolated VFD Bypass setup, allowing the pump to operate from utility power in the event of a VFD failure.
- F. The MCC shall be a Main Lug Only electrical service connection, typically connected to the ATS output.
- G. The MCC shall contain a step down transformer and panelboard for any building required 120/240V single phase services, for a clean electrical installation.

- H. The MCC shall include a local Power Monitor and Display system, showing the status of incoming three phase voltage, current, kVA, kW, kVAR, total harmonic distortion (THD), and power factor minimum.
- I. The MCC shall include an incoming transient voltage surge suppressor for protection against utility transients and lightning induced transients.

1.05 WIRING DEVICES, RACEWAYS, AND CABLE

- A. All interior wiring devices shall be surface mounted, no concealed conduit in the block walls shall be allowed.
- B. All exterior receptacles shall be ground fault interruption circuit (GFIC) with weatherproof while-in-use covers.
- C. For water system installations, interior raceway and exterior raceway above grade shall be Rigid Aluminum Conduit (RAC). Underground raceway shall be PVC Schedule 40. Transitions between below ground and above ground shall be made with PVC Coated Rigid Steel (CGRS) factory elbows.
- D. For wastewater system installations, interior raceway shall be RAC. Exterior raceway shall be CGRS. Underground raceway shall be PVC Schedule 40. Transitions between below ground and above ground shall be CGRS factory elbows.
- E. Cable shall be THHN/THWN for all power circuits. MTW cable shall be utilized for all control wiring within control panels. Shielded cable shall be utilized for all analog signals.

1.06 PUMP WIRING CONNECTION POINTS

- A. For water system installations, the pump may be connected directly to the raceway from the MCC, provided the MCC has lockout/tag out measures.
- B. For wastewater system installations, the submersible pump cable must be connected into a stainless steel junction box. The stainless steel junction box must isolate the pump well from the raceway to the pump MCC to prevent well gases from leaking into the building. Installations which utilize a safety switch must also be isolated from the pump well.
- C. All outdoor safety switches, junction boxes, and other mounting equipment must be minimum type 304 stainless steel.

1.07 TELEMETRY AND PUMP CONTROLS

- A. All pump controls and telemetry for VBMU water and wastewater systems shall be supplied by Micro-Comm Inc. and integrated into the VBMU radio based telemetry and control system.
- B. Wastewater pump well level sensing shall be continuous with 4-20mA output. Float switches for point level control will not be accepted. The preferred method of level sensing shall be the Pulsar Ultrasonic Ultra 3 submersible pressure transmitter, an approved equal, or the current model specified by VBMU. Level sensors shall include a large, non-clog sensing port. Any deviation to ultrasonic level sensing shall be considered on a case-by-case basis by VBMU.
- C. Water tower and reservoir level sensing shall be continuous with 4-20mA output. Float switches for point level control will not be accepted. The preferred method of level sensing shall be a

submersible pressure transmitter, Part No. L5A by Micro-Comm Automation, mounted at the base of the tower or reservoir. However, no pressure sensing for level shall be allowed on the incoming line and must instead be installed on the discharge line of the tank or reservoir. In instances where only one line is used, the level must be sensed by a submersible transmitter installed in the tank, or at another point away from the incoming line pressure.

- D. For installations with flow meters, the local telemetry system shall be capable of daily flow totalization and reporting of instantaneous flow rate.

1.08 LIGHTING AND SECURITY

- A. All interior and exterior lighting shall be LED based for extended lamp life and maintenance costs.
- B. All exterior lighting shall be dusk to dawn photocell operated for site security.
- C. All buildings shall have a 2-inch conduit stub-out for installation of third-party security systems.

END OF SECTION 500 – ELECTRICAL AND INSTRUMENTATION STANDARDS

FORMS

City of Van Buren Municipal Utilities



2806 Bryan Road / P.O. Drawer 1269
 Van Buren, Arkansas 72957
 479-474-5067 / Fax 479-471-8969
 City of Van Buren Municipal Utilities

CORRESPONDING WATER METER AND ADDRESS VERIFICATION FORM

The Developer or Owner is responsible for installing water service lines for multi-family structures to match each water meter in the correct order of the corresponding property addressing system and in the order of the individual unit addresses, e.g., address 2402A, 2402B, 2402C and 2402D. The Developer or Owner shall provide written verification to VBMU that water services are connected from the meters to the correct unit addresses and shall demonstrate compliance when requested by VBMU. Water service may be disconnected by VBMU until out of order service connections are corrected from the water meter to the unit being served.

Confirmation is performed by at least one person operating the water faucets in the unit being served and at least one person observing the flow indicator at the water meter.

Individual Unit Addresses Right to Left per 911 Address Order (To be Completed by VBMU)	Individual Unit Meter Number (To be Completed by VBMU)	Correct Order Confirmed (Owner's Initials)

(Use Additional Forms As Necessary)

Serving Van Buren since 1893
 vbmu.org

SEWER FACILITY OPERATION AND MAINTENANCE AGREEMENT

This Agreement is entered this _____ day of _____, 20____, by and between _____ (“Owner”), and the City of Van Buren, Arkansas acting through the Van Buren Municipal Utilities, a municipal department of the City of Van Buren, Arkansas (“City”). Owner and City shall be collectively referred to as the “Parties.”

WHEREAS, Owner is the record owner of certain real property located at the following address, _____ in Van Buren, Arkansas, and as identified in the legal description as set forth in Exhibit A, attached hereto, (the “Property”); and

WHEREAS, Owner desires to install a private pump station, a private sewer force main, and all appurtenances thereto on the aforesaid Property (collectively known as “Private Sewer Facilities”) to provide for the discharge of the sanitary sewage from the aforesaid premises to City Manhole Number _____ located in the public right-of-way or utility easement at _____ in the City of Van Buren, Arkansas; and

WHEREAS, the City and Owner wish to set forth the agreed upon terms and conditions in this Agreement, which concerns the installation, operation and maintenance of the Private Sewer Facilities.

Sewer Facility Operation and Maintenance Agreement

Owner: _____

Address: _____

Date: _____, 20_____

NOW, THEREFORE, for and in consideration of the mutual promises contained herein and for other good and valuable consideration, the sufficiency of which is acknowledged, the parties agree as follows:

1. TERM:

The City shall allow the Owner to discharge domestic sanitary sewage through the Owner's Private Sewer Facilities and into the City's sewage collection system, as long as the following conditions are satisfied: (i) City facilities remain in service and available; (ii) City facilities have sufficient capacity to convey the discharge of sanitary sewage from Owner's Private Sewer Facilities; (iii) the Owner has not caused or allowed any other connections of a private sewer force main, pump station or private gravity sewer to City facilities without the prior express written consent of the City; and (iv) Owner has not breached any term in this Agreement.

The commencement date upon which such right is granted shall be the date of the last authorized signature (the "Term").

2. OWNER'S RESPONSIBILITIES:

(i) Owner, its successors, heirs, and assigns shall, at its own cost and at no cost to the City, assume all responsibility and liability for the installation, operation, maintenance, design, repair and replacement of the Private Sewer Facilities, including, but not limited to, those placed in the City's rights-of-way;

Sewer Facility Operation and Maintenance Agreement

Owner: _____

Address: _____

Date: _____, 20_____

Owner further agrees that it is familiar with, accepts, and is bound by all requirements, conditions and provisions of the Permit, as well as the following conditions:

- a. The Owner agrees to later relocate or alter all installations interfering with future construction within the right-of-way or other publicly owned facilities without cost to the City. In such event, the relocation or alteration will be made at the Property Owner's expense.
- b. All underground utilities installed pursuant to a right-of-way permit, which cannot accurately be located by ground level visual markers or by magnetic detectors, must be marked by trace wire and a magnetic responsive tape installed directly over such Private Sewer Facilities, which must be a minimum of eighteen (18) inches under the permanent ground level.
- c. The Owner accepts responsibility for the determination of the location and protection of any pre-existing public or private underground utilities and drainage systems. The Owner shall further accept full responsibility for any damage to such underground utilities and systems and shall hold the City harmless by accepting liability for the full cost incurred in repair of any damages caused by the Owner's Private Sewer Facilities, and the installation, repair and maintenance thereof.

(ii) Owner shall timely obtain all necessary approvals, including any approvals required by the Arkansas Department of Health and the Arkansas Department of Environmental Quality, for construction and operation of the Private Sewer Facilities. Owner shall also meet all

Sewer Facility Operation and Maintenance Agreement

Owner: _____

Address: _____

Date: _____, 20_____

applicable local, state and federal laws and regulations pertaining to construction, maintenance and/or operation of the Private Sewer Facilities.

(iii) Owner shall, prior to installation of Private Sewer Facilities, obtain approval from the City for a sewer service connection that will accept the flows from the Private Sewer Facilities.

(iv) Owner represents and warrants that all utility improvements, including, the Private Sewer Facilities, will be constructed, designed, and installed in accordance with the current edition of the Arkansas State Plumbing Code.

(v) Owner shall timely pay all appropriate fees and service charges that are required by the City for sewer service.

(vi) Owner shall reimburse the City for any and all reasonable costs, labor, charges, and expenses associated with the City's excavation and investigation of leaking private facilities located in the public right-of-way that are determined by the City to be owned, maintained, and operated by Owner.

(vii) Owner shall be liable to the City for all costs, fines, charges, fees, and expenses associated with, arising out of or related to the City's response to any calls requesting the City to contain, remove, sanitize or clean-up any effluent discharged from leaks or damaged private force main or private facilities, and Owner shall be liable to the City for any and all reasonable repairs made to Owner's private force main and/or private facilities, and shall indemnify the

Sewer Facility Operation and Maintenance Agreement

Owner: _____

Address: _____

Date: _____, 20_____

City, its departments, employees, representatives, and officials from and against any and all claims based on any theory of liability, including, but not limited to, property damage, personal injury or death, reasonable attorney's fees, costs and expenses.

3. CITY'S RESPONSIBILITIES:

The City's sole responsibility is that it shall, provided that all conditions precedent have been fully satisfied to the sole discretion of the City, allow the Private Sewer Facilities to discharge into the City's manhole number _____ located in the public right-of-way or the utility easement at _____ in the City of Van Buren, Arkansas; and

It is expressly understood by the Parties, that City shall not be responsible for any costs, fees, expenses, or parts thereof, for the design, construction, installation, maintenance, operation, use, damage, or repair of any kind and for whatever reason of Owner's private sewer utility improvements, including, its Private Sewer Facilities.

4. INDEMNIFICATION:

Owner, its successors, heirs and assigns, agree to now and forever, save, indemnify, defend and hold harmless the City, its officials, employees and agents, from and against any and all claims based on any theory of liability, including, but not limited to, claims for damages, fees, charges, penalties, fines, costs, personal injury, death, or arising from the design, operation, malfunction, stoppage, leakage, breakage, maintenance, relocation, replacement, removal or abandonment of the City of Van Buren sewage collection system.

Sewer Facility Operation and Maintenance Agreement

Owner: _____

Address: _____

Date: _____, 20_____

Owner, its successors, heirs, and assigns further agree to now and forever save, indemnify, defend and hold harmless the City, its officials, employees and agents, from and against any and all claims, damages, fees, charges, penalties, fines, costs and liabilities arising from or related to this Agreement, or alleged to arise from, or in any way relating to, the design, installation, operation, malfunction, stoppage, leakage, breakage, maintenance, relocation, replacement, removal, or abandonment of the Private Sewer Facilities, and from and against any and all claims for damages, penalties, fines, fees, costs and claims relating to environmental pollution and unlawful discharges of sewage resulting from or relating to the operation, malfunction, leakage or breakage of the Private Sewer Facilities.

5. UNAUTHORIZED CONNECTION STRICTLY PROHIBITED:

Owner understands and agrees that no other pump stations and/or sewer lines from other parcels of land may connect to the Private Sewer Facilities without the express prior written consent from the City, which such approval shall be within the sole discretion of the Van Buren Municipal Utilities. It is further understood and agreed that no subdivided or resubdivided parcels involving the Property may in any way utilize the Private Sewer Facilities without the express prior written consent of the City.

6. MANDATORY CONNECTION TO CITY SEWER SYSTEM:

Owner shall cause the Property to be connected to the City's gravity sewer and the City's sewer utility improvements when the same becomes available to the Property at the discretion of the Director of Utilities, Van Buren Municipal Utilities. Owner shall at that time be required to pay all applicable fees or charges related thereto.

Sewer Facility Operation and Maintenance Agreement

Owner: _____

Address: _____

Date: _____, 20____

7. MISCELLANEOUS:

This Agreement shall be binding on Owner, its heirs, successors and assigns and shall run with the land identified as the Property, except for any portion(s) thereof which are dedicated to the City of Van Buren, Arkansas.

Witness our hands and seals on this _____ day of _____, 20____

OWNER(S):

Sewer Facility Operation and Maintenance Agreement

Owner: _____

Address: _____

Date: _____, 20____

ACKNOWLEDGEMENT

STATE OF _____)

SS)

COUNTY OF _____)

On this _____ day of _____, 20____, before me, a Notary Public,

duly commissioned, qualified and acting, within and for the County and State aforesaid,

appeared in person the within named _____
name of document signer(s)

to me personally well-known or proven to be the persons whose names appear upon the within and foregoing instrument, and stated and acknowledged that they had executed the same for the consideration, uses and purposes therein mentioned and set forth, and I do hereby so certify.

IN TESTIMONY WHEREOF, I have hereunto set my hand and official seal this _____ day of _____, 20____.

Notary Public

My Commission Expires:

Sewer Facility Operation and Maintenance Agreement

Owner: _____

Address: _____

Date: _____, 20____

EXHIBIT A

Insert a legal description of the Property.

STANDARD SPECIFICATIONS

City of Van Buren Municipal Utilities

SECTION 210 – TRENCHING AND BACKFILLING

PART 1 GENERAL

1.01 SCOPE OF WORK

- A. Furnish all labor, materials, equipment and incidentals required; and perform all trenching for pipelines and appurtenances including excavation, bedding, backfilling, disposal of surplus or unsatisfactory spoil material, and restoration of trench surfaces and easements.
- B. Coordinate all trenching, backfilling and restoration of disturbed areas with the City of Van Buren Municipal Utilities (VBMU).

1.02 RELATED SECTIONS

- A. Section 310 – Water Line Improvements
- B. Section 410 – Sanitary Sewer Line Improvements

1.03 REFERENCE STANDARDS

- A. American Association of State Highway and Transportation Officials (AASHTO), latest edition:
 - 1. AASHTO T 99 Standard Method of Test for Moisture-Density Relations of Soils Using a 2.5-kg (5.5-lb) Rammer and a 305-mm (12-in.) Drop
 - 2. AASHTO T 180 Standard Method of Test for Moisture-Density Relations of Soils Using a 4.54-kg (10-lb) Rammer and a 457-mm (18-in.) Drop
 - 3. AASHTO T 310 Standard Specification for In-Place Density and Moisture Content of Soils and Soil-Aggregate by Nuclear Methods (Shallow Depth)
- B. American Society for Testing and Materials (ASTM), latest edition:
 - 1. ASTM C33 Standard Specification for Concrete Aggregates
 - 2. ASTM D698 Standard Test Methods for Laboratory Compaction Characteristics of Soils Using Standard Effort (12,400 ft-lbf/ft³ (600 kN-m/m³))
 - 3. ASTM D1557 Standard Test Methods for Laboratory Compaction Characteristics of Soils Using Modified Effort (56,000 ft-lbf/ft³ (2,700 kN-m/m³))
 - 4. ASTM D2487 Standard Practice for Classification of Soils for Engineering Purposes (Unified Soil Classification System)
 - 5. ASTM D6938 Standard Test Method for In-Place Density and Water Content of Soil and Soil-Aggregate by Nuclear Methods (Shallow Depth)

- C. Occupational Safety and Health Administration (OSHA), latest edition:
 - 1. All excavation, trenching and related sheeting, bracing, etc., shall comply with the requirements of OSHA safety standards (29 CFR Part 1926.650 Subpart P – Excavation) and any applicable State requirements. Where conflict between OSHA and State regulations exists, the more stringent requirements shall apply.
 - 2. The current edition of Occupational Safety and Health Administration Standard for Excavation and Trench Safety Systems, 29 CFR 1926, Subpart P, is specifically incorporated and made a part of these specifications and contract documents as required by Arkansas Code Annotated 22-9-212.

1.04 SUBMITTALS

- A. Submit the proposed method of backfilling and compaction to the Engineer for review.
- B. Submit an excavation and trench safety plan to the Engineer for review.
- C. Furnish test data to indicate compliance of backfill, bedding and compaction with this specification to the Engineer for review.

1.05 QUALITY ASSURANCE

- A. Furnish the Engineer with supplier certifications and quality assurance testing of all materials from offsite sources including select material, topsoil, sand, rock, and crushed stone.
- B. Conduct quality assurance testing in accordance with the following:
 - 1. Determine a moisture-density relationship for each type of subgrade and backfill material encountered and conduct testing in accordance with AASHTO T 99 (ASTM D698) or AASHTO T 180 (ASTM D1557).
 - 2. Conduct field density and moisture testing of initial trench subgrade and all backfill in accordance with AASHTO T 310 (ASTM D6938). Minimum compaction limits for trench backfill material are defined under paragraph 3.01.D, Backfilling.
 - 3. Testing frequencies for in-place density and moisture are indicated in Table 210.1 below.
 - 4. Should any moisture-density test fail to meet the specified requirements, the Contractor shall perform corrective work necessary to bring the material into compliance and retest the failed area at no additional cost to the Utility.

Table 210.1
Minimum Compaction Testing Frequencies for
Trench Backfill Material

Location	Required Frequency
Within 25 feet of buildings and structures	One (1) moisture-density test per 50 linear feet, every lift of backfill, minimum of (2) tests
Within Van Buren city streets and alleys	Trench backfill shall be with slurry, in accordance with the Van Buren Street Cut Standards, latest edition
Within parking lots, paved and gravel driveways, under sidewalks	Trench backfill shall be with slurry, and in accordance with applicable regulatory agency's requirements, e.g., County or State rights-of-way
When noted on the Drawings	One (1) moisture-density test per 400 linear feet, every lift of backfill
Areas under turf, sodded, planted, or seeded non-traffic areas	Conduct moisture-density tests at the locations and frequencies as directed by the Engineer

PART 2 PRODUCTS

2.01 PIPE BEDDING

- A. Pipe bedding shall conform to the class specified by the Engineer. When no bedding class is specified, the requirements for Class "D" bedding shall apply. If trench conditions are mucky, bedding shall be Class "B".
- B. CLASS "B" GRANULAR BEDDING
 - 1. Class "B" Granular Bedding: Crushed stone or gravel, well graded, and containing several sizes of particles ranging from 3/4-inch maximum to No. 4. Unless otherwise approved by the Engineer, the material shall meet the requirements of ASTM C33, Gradation 67.
- C. CLASS "D" BEDDING
 - 1. Class "D" Bedding: Firm soil excavated from the trench and free of rocks, which will provide uniform bearing for the full length of the pipe barrel.
 - 2. Excavate bell holes in the trench at each joint to permit proper jointing and to prevent the joint of the pipe from being a point of support. Correct over excavation of any portion of the trench with thoroughly compacted soil material approved by the Engineer.

2.02 TRENCH BACKFILL

- A. Trench backfill under un-paved areas shall consist of on-site backfill or select backfill. When no material requirements are specified, the Contractor may use soil material excavated from the trench as backfill, provided that it meets the requirement of On-Site Backfill. If trench spoil is wet, rocky, or contains other objectionable materials, the Contractor shall furnish and install Select Backfill. Unacceptable trench spoil shall be wasted in a manner approved by the Engineer.

- B. Unless otherwise indicated on the Drawings, backfill for trenches and structures in paved areas, parking lots, paved and gravel driveways, alleys, under sidewalks, and under curb and gutter shall be Slurry Backfill.
- C. On-Site Backfill: Backfill shall consist of on-site material excavated from the trenches except where the Drawings require the use of special backfill materials or as directed by the Engineer. On-site backfill material shall be free of rocks, clods or frozen masses over 3 inches in diameter or organic matter. The Engineer will approve backfill material prior to placement in the trench.
- D. Select Backfill: Granular material with a maximum particle size of 3 inches, graded from coarse to fine, conforming to AASHTO classification A-1, A-2-4 or A-2-5, or a sandy or gravely clay conforming to classification A-2-6 or A-6 with the exception that the plasticity index shall not exceed 15. The Contractor shall furnish, at his expense, test data to indicate compliance of select material with this specification.
- E. Slurry Backfill: A plant mixed slurry of sand, cement, fly ash, and water in a ratio of 3,400 lb.: 150 lb.: 100 lb.: 46 gal., respectively. The slurry mixture shall achieve a maximum compressive strength of 300 psi at 28 days.

PART 3 EXECUTION

3.01 TRENCH EXCAVATION AND BACKFILL

- A. General:
 - 1. Excavate the trench so that pipe can be laid to the required lines and grades as indicated on the Drawings. Do not deviate from the required line or grade except with by the written consent of the Engineer.
 - 2. Grade the trench to the approximate depth shown on the Drawings and maintain a depth that will provide not less than 30 inches of cover from the top of the pipe to the finished surface of the ground. Install the pipe to a grade such that the entire line will have a minimum number of high and low points. At utility or street crossings requiring greater line depth, install the pipe approach to the crossing on a gradual and uniform grade.
 - 3. Whenever obstructions not shown on the Drawings are encountered during the progress of the work and interfere to such an extent that an alteration in the Drawings is required, the Engineer shall have the authority to change the Drawings and order a deviation from the line and grade or arrange with the owners of the structures for the removal, relocation or reconstruction of the obstructions,
 - 4. Furnish temporary support and provide adequate protection and maintenance of all underground and surface utility structures, drains, conduits, sewers and other structures encountered in the progress of the work at no additional cost to VBMU. Where the grade or alignment of the pipe is obstructed by existing structures, the Contractor shall permanently support, relocate, remove or reconstruct the obstruction in cooperation with the owners of such utility structures. Determine the location of existing underground utility structures, including coordinating utility location services, examining available records, and making all explorations and excavations necessary to determine the exact location of the underground utility.

5. Proceed with caution in the excavation and preparation of the trench to determine the exact location of underground structures and utilities, both known and unknown. The Contractor is responsible for the repair of structures broken or otherwise damaged because of careless construction procedures.
6. Do not advance the excavation of trenches more than 150 feet ahead of the completed pipe work and completed backfill without permission from the Engineer. Refer to other sections of these Specifications for the requirements for cutting and replacing pavements.
7. Lay water mains at least 10 feet horizontally from any existing or proposed gravity or pressure sewer. Measure the distance from edge to edge. In cases where it is not practical to maintain a 10-ft. separation, deviation must be specifically approved by the Arkansas Department of Health and the Engineer. Vertical separation of water and sewer mains at crossings shall provide for a minimum of 18 inches of distance from the outside of the water line to the outside of the sewer line. At crossings, one (1) full section of water pipe (18 or 20 feet long) shall be laid such that both joints are installed as far from the sewer as possible. Special structural support of the water and/or sewer line may be required by the Design Engineer, i.e., clay, concrete, or pipe encasement.
8. Cut and repair street crossings in accordance with the Van Buren Street Cut Ordinance, county road crossings in accordance with the Crawford County Road Standards, and highway crossings in accordance with the requirements of the Arkansas Department of Transportation (ARDOT). Obtain street or road cut permits for any and all such cuts from the appropriate governmental authority.

B. Excavation:

1. Excavate all the material encountered within the lines and grades shown on the Drawings and as specified and directed by the Engineer. Saw all paved driveway, parking lot and street cuts at the trench limits or as indicated on the Drawings.
2. Below a point 12 inches above the outside top of the pipe, the trench shall have vertical sides and shall have a minimum width as detailed on the Drawings. If no details are shown on the Drawings, the minimum trench width shall be equal to the outside pipe diameter plus 18 inches and a maximum width equal the outside pipe diameter plus 30 inches.
3. At any point where the width of the lower portion of the trench exceeds these limits, the Contractor shall take corrective measures. As directed by the Engineer, the Contractor shall provide either pipe of adequate strength, special pipe embedment, or a concrete cradle as required by the loading conditions. The Contractor shall furnish and install these corrective items at no additional cost to VBMU.
4. Stockpile material suitable for backfilling in an orderly manner a sufficient distance from the banks of the trench to avoid overloading and to prevent slides or cave-ins. Remove or waste all excavated materials not required or unsuitable for backfill as indicated in the Specifications or as directed by the Engineer.
5. Where necessary to protect the labor, the work or adjacent property, the Contractor shall provide and install shoring. The material used shall be of suitable dimensions and strength to prevent the settlement or movement of the ground adjacent to the trench and to prevent damage to surface or subsurface structures. The adequacy and need of the sheeting and bracing shall be the complete responsibility of the Contractor. The shoring shall remain in

place until the backfill has proceeded to a point where it can safely be removed, except that, if in the opinion of the Engineer, damage is likely to result from withdrawing shoring, it shall remain in place. No separate payment will be made for sheeting, shoring and bracing.

6. If the soil at the bottom of the trench is unstable and in such condition that it cannot be properly graded, excavate the trench to a depth determined by the Engineer and backfill to grade with crushed stone or gravel well compacted by tamping.
7. Dewater all excavation before any construction is undertaken therein. Lay all pipe in dry trenches and place all concrete only upon dry and firm foundation material. The Contractor shall pump, bail, or temporarily provide drainage for any water encountered.
8. Should the specified methods of dewatering the trenches be unsuccessful, excavate the trench to a depth of approximately 6 inches below grade. Backfill the trench to grade with gravel bedding. Form a sump below the gravel to provide a place for a pump to take suction and thus lower the water level to a point below the bottoms of the pipe joints. Continue the pumping until the joints have been placed and the presence of water will not injure them. Do not commence backfilling until the trench has been dewatered.
9. If rock is present at the grade line of the trench, excavate it to an elevation approximately 6 inches below grade. Rock shall consist of any solid ledges, bedded deposits, stratified or unstratified masses, or conglomerated or cemented deposits with a volume of 1 cubic yard or more, which in the opinion of the Engineer cannot be excavated with the use of rippers or impact hammers or removed with equipment possessing no less than 120 net horsepower with bucket curling force of not less than 25,000 pounds-force (lbf) and a stick crowd force of not less than 18,500 lbf. The use of explosives is not permitted to remove rock without the expressed permission of VBMU (see Subsection 3.03). The Contractor shall notify the Engineer when rock is encountered and shall allow sufficient time for the Engineer to measure the limits of rock excavation.
10. Where rock is removed from the trench, backfill to grade with crushed stone or gravel. Place this backfill prior to laying the pipe. Remove and dispose of all excavated rock from the site.
11. When indicated on the Drawing or as directed by the Engineer, construct an impervious dam or bulkhead in the trench to interrupt the unnatural flow of groundwater after construction. Key the dam into the trench bottom and sidewalls. Where directed, provide at least one (1) clay or other impervious material dam in the trench line every 300 linear feet of pipe or between each manhole.
12. Avoid heavy machinery traffic above installed pipe until trench backfill is placed and compacted. Monitor pipe deflection during trench backfill.

C. Bedding:

1. Bed all pipe accordance with Subsection 2.01.
2. Prior to installation of the pipe, shape the bedding to provide uniform support for the bottom quadrant of the pipe barrel.
3. Accomplish the placement of material on each side of pipe (haunching) and immediately above the top of the pipe (initial backfill) in a manner that will prevent displacement or deflection of the pipe.

D. Backfilling:

1. Backfill all trenches immediately after the pipe is laid and approved. Install backfill by methods that will not disturb the pipe. Repair pavement cuts with paving materials of the type and design of the original surface. Do not commence pavement repair until the Contractor has achieved proper subgrade compaction. Such backfilling, before pipeline testing, shall not relieve the Contractor of responsibility for correction of leaks in the line.
2. Place backfill up to a level of 12 inches above the top of the pipe by hand shoveling or other approved methods, and deposit backfill in maximum layers of 4 inches. Compact each layer by mechanical tamping. Do not displace pipe during tamping of the backfill. Control the moisture content of the backfill material as required to obtain the specified compaction.
3. From a point 12 inches above the top of the pipe, place backfill by any approved method that will not injure or disturb the pipe and will result in the specified compaction.
4. Unless otherwise noted on the Drawings or more stringent requirements are established by other specification sections, place and insure backfill and fill material to achieve an equal or greater degree of compaction than undisturbed material adjacent to the work. However, in no case shall the degree of compaction fall below the percentages of the maximum density, at optimum moisture content, as indicated in Table 210.2 below.

Location	Required Density
Within 25 feet of buildings and structures	100% of the maximum dry density by Standard Proctor test, AASHTO T 99 (ASTM D698)
Within Van Buren city streets and alleys	Trench backfill shall be with slurry, in accordance with the Van Buren Street Cut Standards, latest edition
Within parking lots, paved and gravel driveways, under sidewalks	Trench backfill shall be with slurry, and in accordance with applicable regulatory agency's requirements, e.g., County or State rights-of-way
When noted on the Drawings	95% of the maximum dry density by Standard Proctor test, AASHTO T 99 (ASTM D698)
Areas under turf, sodded, planted, or seeded non-traffic areas	90% of the maximum dry density by Standard Proctor test, AASHTO T 99 (ASTM D698)

5. When conflicts exist between the densities due to location or depth of trench, the higher specified density shall be required. Compaction densities and testing frequencies for pavement sections are defined in Section 220, Pavement Repairs.
6. All trenches shall be backfilled, settled, and the ground restored to its original condition as soon as possible after the pipe is installed. Any unnecessary delay in restoring trenches to their original condition shall constitute just cause for stopping all other work until the trenches are so restored. The Contractor also shall refill trenches as often as necessary to bring them back to original grade, and during the period when settlement is occurring shall refill them frequently to maintain traffic.

7. If at any time within 12 months after the completion and final acceptance of the work embraced in this Contract, there shall be any settlement of the trenches requiring repairs to be made, VBMU may notify the Contractor to make such repairs as may be necessary. Should the Contractor fail to do so within 15 days after the date of such notice or should the nature of such defect be such as to require immediate attention, VBMU shall make such repairs as may be necessary, and bill the actual cost of such repairs to the Contractor.

3.02 SLURRY BACKFILL

- A. Under city streets and alleys, parking lots, and paved and gravel driveways, backfill trenches with Slurry Backfill. The Contractor shall use this material to help facilitate the reapplication of traffic over the trenches across streets and driveways where dictated by the Engineer. The Engineer may modify the design as required by the construction conditions. Place slurry to neat trench lines as indicated on the Drawings, not to exceed a trench quantity 24 inches wider than the diameter of the pipe in the trench or as indicated on the Drawings.
- B. The Engineer may direct the Contractor to place a temporary surface over the slurry. The Contractor shall consult the trenching details in the Drawings as to the required depth of bedding, slurry and surface material depths. This procedure may be used for water lines, sanitary sewer lines, or other pavement crossings.
- C. Allow utility backfill to achieve a 24-hour set before allowing traffic on it, or before the placement of base course or paving materials. Protect utility backfill against frost and rapid drying.

3.03 EXPLOSIVES

- A. Explosives are prohibited for excavation unless a plan for such use is approved by the Engineer and VBMU, proof of blasting insurance is submitted, and experienced blasting personnel are utilized and licensed in the State of Arkansas.

END OF SECTION 210 – TRENCHING AND BACKFILLING

SECTION 220 – PAVEMENT REPAIRS

PART 1 GENERAL

1.01 SCOPE OF WORK

- A. This work shall consist of the repair of asphalt and concrete pavements within public utility or temporary construction easements. Other work not covered by this Section shall conform to one (1) of the following:
 - 1. The repair of existing pavements or the construction of new pavements within City of Van Buren street rights-of-way shall be done in accordance with the *Van Buren Public Works Standard Specifications*, latest edition, and in accordance with the Van Buren Street Cut Ordinance, including amendments.
 - 2. All pavements, curbing and sidewalks in the Van Buren Historic District shall be repaired or replaced in accordance with the *Design Guidelines: A Guide to Rehabilitation and New Construction for the Van Buren Historic District, Van Buren, Arkansas*, latest edition.
 - 3. Street crossings and repairs of Arkansas State Highways shall be done in accordance with the requirements of the Arkansas Department of Transportation (ARDOT) and project specific utility permits issued by ARDOT.
 - 4. Crossings and repairs of Crawford County roads shall be done in accordance with the requirements of the Crawford County Judge and project specific road crossing permits issued by the Crawford County Road Department.
- B. Coordinate all pavement cuts, repairs and restoration with the City of Van Buren Municipal Utilities (VBMU). ARDOT utility permits shall be obtained by VBMU for projects initiated by the City of Van Buren. For projects initiated by Developers, copies of ARDOT utility permits shall be submitted to VBMU prior to the commencement of the utility work.
- C. Furnish all labor, materials, equipment and incidentals required to repair or replace existing pavement due to installation or repair of water or sewer lines and associated utility improvements.
- D. The Contractor is responsible for complying with all City, County, State, or Federal regulations and requirements for the repair or replacement of pavements and the restoration of rights-of-way. The Contractor is responsible for obtaining all required regulatory permits for street cuts and repairs.
- E. Installation of water or sewer piping and associated improvements may require the repair or replacement of concrete features such as curbing, ditch paving and sidewalks.
- F. Installation of water or sewer piping and associated improvements may require the demolition of paved asphalt and concrete surfaces. Saw cut trench edges through paved areas in straight lines to achieve a consistent repair width. All gravel repairs within paved areas shall conform to the requirements for Base Course.

1.02 RELATED SECTIONS

- A. Section 210 – Trenching and Backfilling
- B. Section 310 – Water Line Improvements
- C. Section 410 – Sanitary Sewer Line Improvements

1.03 REFERENCE STANDARDS

- A. American Association of State Highway and Transportation Officials (AASHTO), latest edition:
 - 1. AASHTO M 17 Standard Specification for Mineral Filler for Bituminous Paving Mixtures
 - 2. AASHTO M 81 Standard Specification for Cutback Asphalt (Rapid-Curing Type)
 - 3. AASHTO M 85 Standard Specification for Portland Cement
 - 4. AASHTO M 140 Standard Specification for Emulsified Asphalt
 - 5. AASHTO M 208 Standard Specification for Cationic Emulsified Asphalt
 - 6. AASHTO T 27 Standard Method of Test for Sieve Analysis of Fine and Coarse Aggregates
 - 7. AASHTO T 30 Standard Method of Test for Mechanical Analysis of Extracted Aggregate
 - 8. AASHTO T 96 Standard Method of Test for Resistance to Degradation of Small-Size Coarse Aggregate by Abrasion and Impact in the Los Angeles Machine
 - 9. AASHTO T 99 Standard Method of Test for Moisture-Density Relations of Soils Using a 2.5-kg (5.5-lb) Rammer and a 305-mm (12-in.) Drop
 - 10. AASHTO T 104 Standard Method of Test for Soundness of Aggregate by Use of Sodium Sulfate or Magnesium Sulfate
 - 11. AASHTO T 164 Standard Method of Test for Quantitative Extraction of Asphalt Binder from Hot Mix Asphalt (HMA)
 - 12. AASHTO T 166 Standard Method of Test for Bulk Specific Gravity (G_{mb}) of Compacted Hot Mix Asphalt (HMA) Using Saturated Surface-Dry Specimens
 - 13. AASHTO T 180 Standard Method of Test for Moisture-Density Relations of Soils Using a 4.54-kg (10-lb) Rammer and a 457-mm (18-in.) Drop
 - 14. AASHTO T 209 Standard Method of Test for Theoretical Maximum Specific Gravity (G_{mm}) and Density of Asphalt Mixtures
 - 15. AASHTO T 310 Standard Specification for In-Place Density and Moisture Content of Soil and Soil-Aggregate by Nuclear Methods (Shallow Depth)

B. American Society for Testing and Materials (ASTM), latest edition:

1. ASTM C33 Standard Specification for Concrete Aggregates
2. ASTM C150 Standard Specification for Portland Cement
3. ASTM D698 Standard Test Methods for Laboratory Compaction Characteristics of Soil Using Standard Effort (12,400 ft-lbf/ft³ (600 kN-m/m³))
4. ASTM D977 Standard Specification for Emulsified Asphalt
5. ASTM D1557 Standard Test Methods for Laboratory Compaction Characteristics of Soil Using Modified Effort (56,000 ft-lbf/ft³ (2,700 kN-m/m³))
6. ASTM D2397 Standard Specification for Cationic Emulsified Asphalt
7. ASTM D6938 Standard Test Method for In-Place Density and Water Content of Soil and Soil-Aggregate by Nuclear Methods (Shallow Depth)

C. Arkansas Department of Transportation (ARDOT):

1. Standard Specification for Highway Construction, latest edition

1.04 SUBMITTALS

- A. Furnish material certifications from the material supplier or material manufacturer to indicate compliance with these specifications. Include analysis or other information when specified or requested by the Engineer.
- B. Furnish test data to the Engineer to indicate compliance with the following:
 1. In-place density of pavement subgrade.
 2. Gradation and mechanical properties of base course material.
 3. Compression strength test results of concrete base course.
 4. In-place density of base course surface repair.
 5. In-place density of asphalt surface repair.

1.05 QUALITY ASSURANCE

- A. Conduct quality assurance testing in accordance with the following minimum frequencies. For small quantities of pavement patching and repair, conduct a minimum of one (1) of each test per day as directed by the Engineer.
 1. Determine a moisture-density relationship for each type of subgrade and aggregate base course material encountered or provided and conduct testing in accordance with AASHTO T 99 (ASTM D698) or AASHTO T 180 (ASTM D1557).

2. Test all aggregates for base course and bituminous mixtures for wear, soundness and gradation in accordance with AASHTO T 96, T 104, T 27 (base course), T 30 (bituminous mixture), respectively. Conduct a minimum of one (1) test each to determine the characteristics of each type of aggregate proposed for the project.
3. Conduct field density and moisture testing of pavement subgrade in accordance with AASHTO T 310 (ASTM D6938). Test in-place density and moisture at a frequency of one (1) test per 5,000 square-feet of subgrade.
4. Compact base course to a density of not less than 95% of theoretical density unless otherwise indicated. Conduct field density and moisture testing of aggregate base course in accordance with AASHTO T 310 (ASTM D6938). Test in-place density and moisture at a frequency of one (1) test per 5,000 square-feet of base course.
5. Test bituminous mixtures for maximum specific gravity, extraction and gradation in accordance with AASHTO T 209, T 164 and T 30, respectively. Conduct bitumen extraction and sieve analysis of extracted aggregate at a frequency of one (1) test each per 300 tons of asphalt surface course.
6. Compact finished asphalt surface courses to a density of not less than 92% of theoretical density. Collect samples for the determination of density from the finished pavement by coring and test for bulk specific gravity in accordance with AASHTO T 166. The testing laboratory taking such samples shall repair the cuts in a manner approved by VBMU and the Engineer. Test in-place thickness and density at a frequency of one (1) test each per 400 linear-feet of pavement and at least one (1) per each pavement repair.

PART 2 PRODUCTS

2.01 ASPHALT PAVEMENT MATERIALS

- A. The mineral aggregates for Asphalt Concrete Hot Mix (ACHM) Surface Course shall consist of combinations of coarse aggregate, fine aggregate, and mineral filler proportioned as described in Table 220.1 below. All materials used shall comply with ARDOT Standard Specification Section 409 and this Subsection.
- B. Asphalt concrete hot mix surface course shall be Surface Type 3. Surface Type 2 hot mix shall be used only when specifically authorized and directed by the Engineer. Both Surface Type 2 and Type 3 shall conform to the requirements of Table 220.1 on the following page.
- C. The aggregates, mineral filler, and asphalt binder shall be measured separately and accurately mixed in the proper proportions according to the mix design. The aggregates shall be thoroughly coated, and the mixture shall not show an excess or deficiency of asphalt binder, injury or damage due to burning or overheating, or an improper combination of aggregates.
- D. The mineral aggregate in the Surface Course shall contain, if required by laboratory mix design, mineral filler complying with the physical requirements of AASHTO M 17. When required by the mix design, the asphalt binder shall contain a heat-stable anti-strip additive. It shall be added at the rate determined by the laboratory mix design. The anti-strip additive shall be added by an in-line blending process just before introduction of the asphalt binder to the mixer.

Sieve Size	Type 2 Asphalt Percent Passing	Type 3 Asphalt Percent Passing
1 inch	--	--
3/4 inch	100%	--
1/2 inch	85% - 100%	100%
#4	47% - 80%	54% - 80%
#8	28% - 63%	32% - 64%
#16	19% - 50%	22% - 51%
#30	13% - 40%	14% - 43%
#50	8% - 29%	8% - 32%
#100	5% - 20%	5% - 21%
Fines to Asphalt Ratio	0.6 - 1.4	0.6 - 1.4
Asphalt Binder Content	4.5% - 7.5%	4.5% - 7.5%

- E. The Contractor shall furnish certifications of material manufacture, analysis or other information when specified or requested by the Engineer.

2.02 TACK COAT

- A. Materials shall conform to the requirements below. For tack coats, a rapid curing cut-back, a cationic emulsified asphalt (CSS-1 or -1h), or an anionic emulsified asphalt (SS-1 or -1h) will be used. Dependent upon the texture of the base and the season of the year that the work is being performed, the Engineer will select the particular grade of the type of asphalt material that will be used. Samples of asphalt material will be tested according to applicable AASHTO or ASTM methods.
1. Rapid Curing Cut-back Asphalt (RC-70, -250, -800 or -3000) shall conform to the requirements of AASHTO M 81.
 2. Anionic Emulsified Asphalt (SS-1, or SS-1h) shall conform to the requirements of AASHTO M 140 (ASTM D 977).
 3. Cationic Emulsified Asphalt (CSS-1 or CSS-1h) shall conform to the requirements of AASHTO M 208 (ASTM D 2397).

2.03 CONCRETE

- A. All concrete shall be Class "B", 3,500 psi (5-1/2 bag), air entrained, and fiber reinforced. The maximum size of aggregate used shall be 1-1/2 inches with a gradation conforming to ASTM C33, Gradation No. 467.
- B. High Early Strength Concrete shall be made with the use of high early strength cement complying with ASTM C150 (AASHTO M 85), Type III cement. Upon written approval of the Engineer, the Contractor may substitute Type I cement with a cement factor of 25% in excess of that

specified for the Type III cement or Type I cement combined with approved admixtures, at no additional cost to VBMU.

2.04 FLOWABLE FILL (SLURRY BACKFILL)

- A. Flowable Fill shall conform to Subsection 3.02, Slurry Backfill in Section 210, Trenching and Backfilling.

2.05 BASE COURSE

- A. Obtain base course material from approved sources with approved crusher equipment. Handle the materials in such a manner that secures a uniform and satisfactory product. Unless otherwise noted, crushed stone base course material shall conform to Class 7 Aggregate Base Course as described in Table 220.2.

Sieve Size	Percent Passing
1-1/2 inch	100%
1 inch	60% - 100%
3/4 inch	50% - 90%
#4	25% - 55%
#40	10% - 30%
#200	3% - 12%

- B. Material shall consist of crusher run stone or a mixture of crushed stone (90% minimum crusher-run material) and soil mortar uniformly mixed and so proportioned as to meet all the requirements specified herein. The stone shall be hard and durable with a percent of wear of not greater than forty-five (45), as determined by the Los Angeles Abrasion Test.
- C. The fraction passing the #200 sieve shall not be greater than two-thirds (2/3) of the fraction passing the #40 sieve. The fraction passing the #40 sieve shall have a Liquid Limit (L.L.) not greater than twenty-five (25) and Plasticity Index (P.I.) not greater than six (6).
- D. The material shall not contain more than 5% by weight of shale, slate, or other objectionable, injurious, or deleterious matter.

PART 3 EXECUTION

3.01 PAVEMENT CONSTRUCTION METHODS

- A. Surface Patch:
 - 1. Surface patch shall consist of removing and replacing the existing asphalt surface course. The existing asphalt surface course shall be removed in square or rectangular sections and shall be removed to the full depth of the surface course. Pavement cuts shall be straight and vertical and shall be cut with a saw or air spade. The area to be patched shall be cleaned; re-compacted to 100% as specified in Section 210, Trenching and Backfilling; and a tack coat applied. Asphalt concrete surface course (Type 3) shall be placed in the patch area and shall

be compacted by rolling. The finish surface of the patch shall be uniform and shall match the surrounding pavement slope and grade. The density and surface smoothness of the patch shall meet the requirements specified below.

B. Deep Patch:

1. Deep patch shall consist of removing and replacing the entire pavement section, including surface course(s) and base course, to a minimum depth of 6 inches below the proposed finished pavement grade, and shall include compaction of the subgrade. The existing pavement within the limits of the patch shall be removed in square or rectangular sections. Pavement cuts shall be straight and vertical and shall be cut with a saw or air spade. Forms shall be used for the placement of deep patch materials where directed by the Engineer. The patch area shall be cleaned, and all existing materials removed unless otherwise directed by the Engineer.
2. The exposed subgrade shall be compacted by rolling or by other approved equipment and shall be compacted to 100% of Standard Proctor (Method D) as specified in Section 210, Trenching and Backfilling. Where unstable subgrade is encountered, the Contractor shall undercut the subgrade and backfill with crushed stone or select material as authorized and directed by the Engineer and as specified in Section 210.
3. Replacement of the base shall include furnishing and installing Portland Cement Concrete Base (High Early Strength) to a minimum depth of 6 inches. A tack coat shall be applied to the surface of the concrete at a rate of 0.10 to 0.15 gallons per square-yard, prior to placement of the asphalt surface.
4. The surface of the deep patch shall be given a "Tined" finish. The deep patch shall be floated, and then a metal tine finishing device shall be used to cut continuous grooves across the surface of the deep patch. The grooves produced shall be transverse to the centerline of the pavement and shall be from 1/8 inch to 3/16 inch in depth and width. The grooves shall be spaced on 1/2-inch to 3/4-inch centers.
5. The Engineer shall decide when the base course shall be opened to traffic and/or when placement of pavement surfacing can proceed. The base course shall not be subjected to any traffic until it has reached 75% of the design strength. If High Early Strength Concrete is used, the base course may be opened to traffic in 24 hours, or earlier if previous test data indicates adequate strengths. Traffic may be placed on the deep patch areas prior to placement of the overlay if temporary ramps, constructed of asphalt concrete cold plant mix, are installed to provide smooth transitions between patch areas and existing pavement surface.

3.02 PAVEMENT SMOOTHNESS

- A. Asphalt concrete surface courses shall be placed and finished to the grades and slopes shown on the Drawings. Surface courses shall be true to the existing pavement grade and cross section.
1. Surface Courses: When checked with a 10-foot straight edge placed parallel to the centerline, the finished surface shall show no variation more than 1/8-inch for surface courses. When surface tests indicate that surface tolerances do not meet these requirements, changes to the paving operations shall be made before beginning the next day's operations. All transverse joints shall have straight edges immediately following rolling of the joint.

2. Corrective Measures: Areas not meeting the above surface test requirements shall be corrected in such a manner as to maintain a quality pavement having the same uniform texture and appearance as the adjoining surface. Skin patching the final surface course will not be permitted. All work and material necessary to correct surface tolerance deficiencies for surface courses shall be at no cost to VBMU.
 3. The Engineer will determine the extent of removal and replacement of pavement and corrective work to be done. The Engineer may order additional density tests to delineate failure areas. The cost of these additional tests shall be at the expense of the Contractor.
- B. Fill and compact holes produced by core sampling with asphalt concrete hot mix.

3.03 CURB AND GUTTER

- A. The repair and/or construction of curb and gutter within City of Van Buren street rights-of-way shall be done in accordance with the *Van Buren Public Works Standard Specifications*, latest edition.
- B. Construct curb and gutter on a prepared sub-base, in accordance with these Specifications and the details as shown on the Drawings.
- C. The sub-grade shall be free of organic materials, soft clay, spongy material or any other objectionable material. Prepare the sub-grade in accordance with the section on base course and to a proper shape to conform to the accepted cross sections and grade.
- D. Provide concrete forms of wood or metal, straight, free from warps or kinks and of sufficient strength. Stake forms securely to resist the pressure of the concrete without spring. Prior to placing concrete, bring the forms to the true approved line and grade and keep them aligned until the concrete has set. Where a face form for a curb is used, it shall be so designed as to permit it to be securely fastened to the other forms.
- E. Moisten the sub-grade prior to placing concrete. Place the concrete, mixed to the proper consistency, in the forms and tamp thoroughly so that all honeycombing will be eliminated, and sufficient mortar will be brought to the surface. Bring the concrete to a smooth, even finish by means of wood float or trowel.
- F. Spade all faces adjacent to the forms so that after forms are removed, the surfaces will be smooth, even and free of honeycomb. Tool all edges round.
- G. Place 3/4-inch expansion joints at intervals not to exceed 60 feet or as shown on the Drawings. Score the concrete to a depth equal to one-third (1/3) the total depth of the concrete at intervals of not greater than 10 feet or less than 5 feet unless otherwise shown on the Drawings.
- H. Protect concrete from curing too rapidly. When curb and gutter or swale sections are completed, spray them with a concrete curing compound or keep them moist by using wet burlap for a period of three (3) days. Keep the surface thoroughly damp between the completion of the finishing operations and the application of the curing compound.
- I. Backfill the curb and gutter immediately after removing the forms. Backfill with selected material placed and compacted in layers not to exceed 4 inches in depth.

3.04 CONCRETE DITCH PAVING

- A. The repair and/or construction of concrete ditch paving within City of Van Buren street rights-of-way and easements shall be done in accordance with the *Van Buren Public Works Standard Specifications*, latest edition.
- B. Excavate the ditch subgrade to the required depth. Remove all soft or yielding material and replace it with suitable material, thoroughly compacted.
- C. Provide concrete forms that are clean, oiled, free from warps, sufficiently strong to maintain alignment, and securely staked and braced. Spade or vibrate the concrete to prevent honeycomb and finish with a wood float. Round all edges with a 1/4-inch edger.
- D. Tool transverse contraction joints with a 1/4-inch jointer or saw cut joints at intervals not greater than 5 feet measured longitudinally along the flow line.
- E. Install an expansion joint at each structure with a space of not less than 1 inch left between the paving and the structure. Fill the space with a poured bituminous joint filler. Maximum spacing of expansion joints shall be 50 feet and at all structures.

3.05 CONCRETE WALKS

- A. The repair and/or construction of concrete sidewalks within the City of Van Buren street rights-of-way or easements shall be done in accordance with the *Van Buren Public Works Standard Specifications*, latest edition, and in accordance with the Van Buren Sidewalk Ordinance, including amendments.
- A. Excavate the sidewalk subgrade to the required depth. Remove all soft and yielding material and replace it with suitable material, thoroughly compacted with approved mechanical equipment.
- B. Provide concrete forms that are clean, oiled, and sufficiently strong to resist springing, and securely staked and braced.
- C. Place concrete on wetted subgrade, compacted and finished with a wood float. Lightly broom the sidewalk concrete and round all edges with a 1/4-inch edger
- D. Tool transverse contraction joints with a 1/4-inch jointer or saw cut joints at intervals not greater than 4 feet measured along the length of the sidewalk.
- E. Install a 1/2-inch expansion joint at intervals of 50 feet and at the intersection with all fixed structures. Install bituminous preformed expansion joint material as the concrete is placed and seal the joint.
- F. Grade and construct the concrete walk so that it is flush with the adjacent finished grade and such that drainage will pass unimpeded across the sidewalk.

END OF SECTION 220 – PAVEMENT REPAIRS

THIS PAGE LEFT BLANK INTENTIONALLY

SECTION 230 – SITE RESTORATION

PART 1 GENERAL

1.01 SCOPE OF WORK

- A. Furnish all labor, materials, equipment and incidentals; place topsoil; provide finish grading; and apply lime, fertilizer, seed, mulch and water on all areas that have been disturbed by construction work.
- B. Completion of work shall comply with stormwater permitting requirements of Arkansas Department of Environmental Quality.
- C. The restoration of all disturbed areas shall be to the satisfaction of the property owner, the Engineer, and the City of Van Buren Municipal Utilities (VBMU).

1.02 RELATED SECTIONS

- A. Section 210 – Trenching and Backfilling
- B. Section 220 – Pavement Repair

1.03 SUBMITTALS

- A. Submit material and equipment furnished under this Section including seed mixtures and product label information to the Engineer for review. Seed certificates shall include guaranteed percentages of purity, weed content, and germination, and shall indicate the net weight and date of shipment. No seed shall be sown until the certificates have been submitted to the Engineer.

PART 2 PRODUCTS

2.01 MATERIALS

- A. Topsoil shall be fertile, friable, loamy surface soil without admixture and free of stones, stumps, roots, sticks, debris, and clay balls greater than 1 inch in diameter. Topsoil shall be stripped from naturally well-drained sites and be free of noxious weeds and other materials deleterious to plant growth. It shall have a pH range of 5.5 to 7.5 and have a minimum organic content of two (2) percent (2%).
- B. Lime shall be agricultural grade ground limestone or approved equivalent, containing not less than 85% calcium and magnesium carbonates.
- C. Fertilizer shall be a commercial grade, 10-20-10, uniform in composition, suitable for application with mechanical equipment, and conforming to State fertilizer laws. Deliver fertilizer to the site in original, unopened containers, bearing the name, trademark and manufacturer's guaranteed analysis. Store fertilizer so that it remains dry and free flowing.
- D. The seed shall be labeled in accordance with current rules and regulations of the Arkansas State Plant Board, shall have a minimum of 98% pure seed and 85% germination by weight, and shall contain no more than 1% weed seeds. A combined total of fifty (50) noxious weed seeds shall be the maximum amount allowed per pound of seed with the following exceptions: Johnson grass

seed, wild onion seed, wild garlic seed, field bindweed seed, or nut grass seed will not be allowed in any amount whatsoever. Deliver seed in original, unopened containers, bearing the name, trademark and warranty of the producer. Seed that has become wet, moldy or otherwise damaged in transit or in storage will not be acceptable.

- E. Mulch cover shall consist of straw from threshed rice, oats, wheat, barley or rye; of wood excelsior; or from hay obtained from various legumes or grasses, such as lespedeza, clover, vetch, soybeans, Bermuda, carpet sedge, Bahia, fescue, or a combination thereof. Mulch shall be dry and reasonably free from Johnson grass or other noxious weeds and shall not be excessively brittle or in an advanced state of decomposition. All material will be inspected and approved prior to use.
- F. Water shall be of irrigation quality and free of impurities that would be detrimental to plant growth.

PART 3 EXECUTION

3.01 GENERAL

- A. Seeding shall consist of furnishing and applying seed, mulch, water, and fertilizer on all areas that have been disturbed by the construction work. These areas shall include lawns, pastures, ditches, ditch banks, embankment areas, compacted fill areas, cut or fill slopes and any area disturbed by construction.
- B. Perform seeding, mulching and conditioning only during those periods within the season that are normal for such work as determined by the weather and locally accepted practice, as approved by the Engineer.

3.02 APPLICATION

- A. Unless otherwise shown on the Drawings, place topsoil to a minimum depth of 4 inches.
- B. For all areas to be seeded:
 - 1. Obtain soil samples, to a depth of 5 inches, from each major soil area, and have a lime requirement analysis conducted. Apply lime at the rate determined by the requirement test.
 - 2. Apply fertilizer at a rate of 800 lbs per acre.
 - 3. Apply grass seed, composed of the varieties (premixed) and at the rates indicated in Table 230.1 below.
 - 4. Apply mulch cover at a rate of 4,000 lbs per acre.

Table 230.1
Grass Seed Varieties and Application Rates

Dates	Variety	Lbs/Acre
Mar. 15 – Jun. 15	Bermuda Grass (Common) unhulled	25
	Bermuda Grass (Common) hulled	25
	Red Fescue	20
	Annual Rye	30
Jun. 15 – Sep. 15	Bermuda Grass (Common) unhulled	25
	Bermuda Grass (Common) hulled	25
	Red Fescue	20
Sep. 15 – Nov. 15	Bermuda Grass (Common) unhulled	10
	Red Fescue	20
	Annual Rye	30

3.03 INSTALLATION

A. Seed Bed Preparation

1. Remove and dispose of off-site all excess dirt, construction materials, trees, rubbish, debris, roots and stumps. Rake to loosen the subgrade immediately prior to the application of topsoil and remove all rubbish, sticks, roots and stones larger than 2 inches. Subgrade shall be inspected and approved by the Engineer before placing topsoil.
2. Place topsoil over approved areas to a depth sufficiently greater than required so that after natural settlement and light rolling, the complete work will conform to the lines, grades and elevations shown on the Drawings or as directed by the Engineer. Do not spread topsoil in water or while frozen or muddy.
3. Uniformly spread lime and then thoroughly pulverize the seedbed by means of disk harrows, hand raking, or other approved methods, thoroughly mixing lime and soil to a depth of 4 inches. Remove rocks, large clods, lumps, brush, roots, litter, and other objectionable foreign matter turned up during mixing, and apply water in order to maintain the desired moisture content in the soil. Follow disk harrowing with a spiked-tooth harrow to provide a finer surface texture.

B. Fertilizing

1. Apply fertilizer uniformly and incorporate it into the soil to a depth of at least 2 inches. Fertilizer may be worked into the soil alone or in conjunction with the required lime.
2. Roll the prepared surface with a hand roller weighing not more than 100 lbs/ft. of roller width. Refill with additional topsoil and regrade all depressions caused by settlement during rolling.

C. Seeding

1. Place seed within ten (10) days following soil preparation.

D. Mulching

1. Immediately after seeding, spread mulch uniformly over the entire area with power mulching equipment or by other approved method. Mulch shall be anchored or otherwise stabilized to hold the mulch in place until the seedbed has germinated. Asphalt may not be used as an anchoring agent. Mulch that is windblown or otherwise disturbed shall be replaced, and the excess shall be promptly removed from the site.

E. Water

1. After application of the mulch cover, apply water in sufficient quantity to moisten thoroughly the soil to a depth of pulverization and as necessary to germinate the seed and maintain growth at the direction of the Engineer until the completion and acceptance of the project by VBMU. The time required for application of water will not be included in the computations of contract time for completion of the project provided all other work under the contract has been completed.
2. Water used in the seeding operation will not be furnished by VBMU. Make provision to obtain water for this operation at no additional cost to VBMU.

3.04 SEEDING IN WOODED AND UNGRADED AREAS

- A. For preparation and seeding in wooded areas and where no grading is required, all of the specified materials and procedures shall be utilized except that no disking shall be performed within the drip line of trees to be preserved. The seedbed shall be prepared by the addition of a thin layer of topsoil approximately 1 inch deep.

3.05 CLEANUP

- A. Prior to final acceptance and payment, the Contractor shall remove all machinery, equipment, surplus materials, rubbish, etc., from the project. Pavement, driveways, sidewalks, and storm drainage facilities shall be cleaned, and all soils or other debris removed.

3.06 MAINTENANCE AND PROVISIONAL ACCEPTANCE

- A. Keep all seeded areas watered and in good condition, reseeding if and when necessary, until a good, healthy, uniform growth is established over the entire area. Maintain these areas in an approved condition including a minimum of two (2) mowings of all seeded and restored areas until acceptance by VBMU.
- B. Provide against washouts on slopes by an approved method. Any washouts that occur through the project warranty period shall be regraded and reseeded at the Contractor's expense until a good sod is established.
- C. An inspection by the Engineer will determine whether maintenance shall continue in any area or manner.

- D. After all necessary corrective work and cleanup has been completed, the Engineer will certify in writing the provisional acceptance of the seeded and restored areas.

END OF SECTION 230 – SITE RESTORATION

THIS PAGE LEFT BLANK INTENTIONALLY

SECTION 310 – WATER LINE IMPROVEMENTS

PART 1 GENERAL

1.01 SCOPE OF WORK

- A. Furnish all labor, materials, equipment and incidentals required to install and test water mains and water services, including all appurtenances.
- B. Coordinate all water line work with the City of Van Buren Municipal Utilities (VBMU), including water main and service line taps, connections to existing water mains requiring interruption of water service to customers, operation of isolation valves and hydrants, pressure testing, disinfection and system flushing, sampling for bacteriological testing, and installation and connection of water services.

1.02 RELATED SECTIONS

- A. Section 210 – Trenching and Backfilling
- B. Section 220 – Pavement Repair
- C. Section 230 – Site Restoration
- D. Section 320 – Water Valves, Hydrants and Meters
- E. Section 330 – Testing of Water Line Improvements

1.03 REFERENCE STANDARDS

- A. American Society of Mechanical Engineers (ASME), latest edition:
 - 1. ASME B1.20.1 Pipe Threads, General Purpose (Inch)
- B. NSF International / American National Standards Institute / (NSF/ANSI), latest edition:
 - 1. NSF/ANSI Standard 14: Plastic Piping Systems Components and Related Materials
 - 2. NSF/ANSI Standard 61: Drinking Water System Components - Health Effects
 - 3. NSF/ANSI Standard 372: Drinking Water System Components - Lead Content
- C. American Society for Testing and Materials (ASTM), latest edition:
 - 1. ASTM A48 Standard Specification for Gray Iron Castings
 - 2. ASTM A536 Standard Specification for Ductile Iron Castings
 - 3. ASTM B88 Standard Specification for Seamless Copper Water Tube
 - 4. ASTM C33 Standard Specification for Concrete Aggregates

5. ASTM D1784 Standard Classification System and Basis for Specification for Rigid Poly(Vinyl Chloride) (PVC) Compounds and Chlorinated Poly(Vinyl Chloride) (CPVC) Compounds
6. ASTM D1785 Standard Specification for Poly(Vinyl Chloride) (PVC) Plastic Pipe, Schedules 40, 80, and 120
7. ASTM D2239 Standard Specification for Polyethylene (PE) Plastic Pipe (SIDR-PR) Based on Controlled Inside Diameter
8. ASTM D2241 Standard Specification for Poly(Vinyl Chloride) (PVC) Pressure-Rated Pipe (SDR Series)
9. ASTM D2737 Standard Specification for Polyethylene (PE) Plastic Tubing
10. ASTM D3035 Standard Specification for Polyethylene (PE) Plastic Pipe (DR-PR) Based on Controlled Outside Diameter
11. ASTM F441 Standard Specification for Chlorinated Poly(Vinyl Chloride) (CPVC) Plastic Pipe, Schedules 40 and 80

D. American Water Works Association (AWWA), latest edition:

1. AWWA C104 Cement-Mortar Lining for Ductile Iron Pipe and Fittings for Water
2. AWWA C105 Polyethylene Encasement for Ductile iron Pipe Systems
3. AWWA C110 Ductile iron and Gray-Iron Fittings
4. AWWA C111 Rubber Gasket Joints for Ductile iron Pressure Pipe and Fittings
5. AWWA C150 Thickness Design of Ductile iron Pipe
6. AWWA C151 Ductile iron Pipe, Centrifugally Cast, For Water
7. AWWA C153 Ductile iron Compact Fittings
8. AWWA C600 Installation of Ductile Iron Water Mains and Their Appurtenances
9. AWWA C651 Disinfecting Water Mains
10. AWWA C700 Cold-Water Meters – Displacement Type, Bronze Main Case
11. AWWA C900 Polyvinyl Chloride (PVC) Pressure Pipe and Fabricated Fittings, 4 In. Through 12 In. (100 mm Through 300 mm), for Water Transmission and Distribution
12. AWWA C901 Polyethylene (PE) Pressure Pipe and Tubing, 1/2 In. (13 mm) 3 In. Through (76 mm) for Water Service

1.04 SUBMITTALS

- A. Submit shop drawings and product data to the Engineer for review.
- B. When required by VBMU or the Engineer, submit a tabulated laying schedule that references stations and piping elevations as shown on the Drawings as well as all fittings, bends, outlets, restrained joints, tees, special deflection bells, adapters, solid sleeves and specials, along with the manufacturer's drawings and specifications indicating complete details of all items. The laying schedule shall show pipe class, class coding, station limits and transition stations for various pipe classes. Submit laying schedule to the Engineer for approval before manufacture and shipment. The location of all pipes shall conform to the locations indicated on the Drawings.
- C. Prior to shipment of pipe, submit a certified affidavit of compliance from the manufacturer stating that the pipe, fittings, gaskets, linings and exterior coatings for this project have been manufactured and tested in accordance with AWWA and ASTM standards and requirements specified herein.

1.05 QUALITY ASSURANCE

- A. Furnish all pipe and fittings from manufacturers experienced in the manufacture of the items. It is not necessary that a single manufacturer furnish all the pipe and fittings, provided that the pipe and fittings are all compatible. Design, construct and install all piping systems and appurtenances in accordance with the best practices and methods, and suitable for the intended service.
- B. Inspect and test all pipe and fittings at the factory as required by the standard manufacturing specifications.
- C. VBMU may elect to hire an independent testing laboratory, at VBMU's expense, to inspect all pipe and fittings at the plant for compliance with these Specifications.
- D. The Engineer or other representative of VBMU may inspect the pipe and fittings after delivery. The pipe will be subject to rejection at any time because of failure to meet any of the Specification requirements, even though sample pipes may have been accepted as satisfactory at the place of manufacture. The Engineer will mark pipe rejected after delivery for identification, and the Contractor shall remove the pipe from the project.
- E. Permanently mark all pipe and fittings with the following information:
 - 1. Manufacturer and date,
 - 2. Size, type, class, or wall thickness,
 - 3. Standard produced to (AWWA, ASTM, etc.).

1.06 DELIVERY, STORAGE AND HANDLING

- A. Comply with manufacturer's ordering instructions and lead time requirements to avoid construction delays.
- B. Exercise care in loading, transporting and unloading to prevent injury to the pipe or coatings. Under no circumstances shall pipe joints or fittings be dropped or skidded against each other. Use

padded slings, hooks, or pipe tongs to prevent damage to the external surface coating or internal lining of the pipe.

- C. Store materials protected from damage and exposure to harmful weather conditions. Keep the interior of all pipe joints, fittings and other appurtenances free from dirt or foreign matter.
- D. Do not stack pipe higher than the limits recommended by the pipe manufacturer. Keep the bottom tier off the ground on timbers, rails or concrete.

1.07 COORDINATION

- A. Verify at the site both the dimensions and work of other trade's adjoining items of work in this Section before commencement of items specified herein.
- B. Do not disrupt service to water or other utility customers during installation of the water line improvements except for the time required to make connections to a new water main.
- C. Notify VBMU and the Engineer at least 48 hours prior to scheduled connections of mains. Scheduling shall be subject to the approval of VBMU and the Engineer.
- D. Schedule the sequence of construction generally as follows:
 - 1. Install new mains as shown on the Drawings, including fire hydrants,
 - 2. Connect new mains to the water system as shown on the Drawings,
 - 3. Test, disinfect and sample mains as specified. After samples are approved, place mains into service.
- E. Work may proceed on one (1) or more water lines simultaneously; however, once work has commenced on any given line, continue that construction until its completion.
- F. Vary the sequence of construction as directed by the Engineer.

1.08 FIELD MEASUREMENTS

- A. Take field measurements at the site to verify or supplement indicated dimensions and to ensure proper coordination of all other construction items.

PART 2 PRODUCTS

2.01 GENERAL

- A. All materials and construction methods shall conform to these specifications and with the standards referenced herein. Manufacturer shall furnish certification of compliance with the referenced standards.
- B. Unless otherwise indicated on the Drawings, water lines 4 to 12 inches in diameter shall be ductile iron pipe or PVC pipe. Water lines that are larger than 12 inches in diameter or will be installed 8 feet or deeper from the proposed finished grade shall be constructed of ductile iron pipe.

- C. All materials and components in potable (drinking) water systems shall comply with the federal definition of “lead free” and the requirements of Public Law 111-380 titled “Reduction of Lead in Drinking Water Act”. Materials and components shall show certification in accordance with NSF Standard 61, Annex G or NSF Standard 372.

2.02 DUCTILE IRON PIPE

- A. Ductile iron (DI) pipe, 4-inch diameter and larger: Push-on joint pipe, cement lined and with a bituminous exterior coating, conforming to AWWA C104, C111 and C151. Unless otherwise noted on the Drawings or in the bid proposal, provide Class 350 pipe for 4-inch to 20-inch diameter and Class 250 for 24-inch diameter and larger in accordance with AWWA C150. Provide restrained pipe joints and install polyethylene wrap where indicated on the Drawings or as indicated on the bid proposal.

2.03 PVC PIPE

- A. Polyvinyl chloride (PVC) pressure pipe, 4-inch diameter and larger: Push-on joint pipe conforming to AWWA C900 with cast iron outside diameter, elastomeric-gasket type joints with integral bell, and minimum pressure Class 150 unless otherwise specified on the Drawings or in the bid proposal. All PVC water lines shall have a Mega-Stop Series 5000 by EBAA Iron or approved equal installed on all pipe joints to prevent the over-insertion of spigots.
- B. Polyvinyl chloride (PVC) pressure pipe, 2-inch to 3-inch diameter: Push-on joint pipe conforming to ASTM D2241 with elastomeric-gasket type joints and integral bell, and minimum pressure Class 200 unless otherwise specified on the Drawings or in the bid proposal.
- C. Polyvinyl chloride (PVC) pressure pipe, 1/2-inch to 1-1/2-inch diameter: Type I, Grade 1 PVC 1120 compounds; conforming to ASTM D1784, Cell Class 12454-B and ASTM D1785; and Schedule 80 unless otherwise specified on the Drawings or in the bid proposal.
- D. Chlorinated polyvinyl chloride (CPVC) pressure pipe: Type IV, Grade 1 CPVC 4120 compounds; conforming to ASTM D1784, Cell Class 23447 and ASTM F441; and Schedule 80 unless otherwise specified on the Drawings or in the bid proposal.

2.04 FITTINGS

- A. Fittings: Ductile iron, cement lined, bituminous exterior coated, polyethylene wrapped, conforming to AWWA C110 or C153 (compact fittings); pressure Class 350 unless otherwise specified on the Drawings or in the bid proposal. Furnish and install restrained push-on joint or restrained mechanical joint fittings unless otherwise designated on the Drawings.
- B. Furnish mechanical joints with anchor fittings or restrained glands if specified on the Drawings or in the bid proposal. Design restrained glands suitable for use with the pipe material, similar and equal to Megalug retainer glands as manufactured by EBAA Iron Sales, Inc.

2.05 SERVICE LINES

- A. Water service line shall be 3/4 or 1-inch diameter or as shown on the Drawings and shall be either copper or plastic tubing. Copper tubing shall conform to ASTM B88 and shall be type K suitable for flared fittings.

- B. Flexible plastic tubing shall be manufactured of high density polyethylene (HDPE) in accordance with AWWA C901; NSF Standard 14 and 61; and ASTM D2239, D2737 and D3035. The outside diameter of all plastic tubing shall be same as copper tubing. All plastic tubing shall be capable of maintaining a pressure of 200 psi at 23 degrees C for 1,000 hours, shall have a minimum working pressure rating of 200 psi and DR of 9, and shall be approved by NSF International. If compression fittings are used on plastic tubing, stainless steel stiffener inserts shall be used at each end. Flexible plastic tubing for service lines shall be Pure-Core SDR 9 CTS by J.M. Eagle or approved equal.
- C. Service line street crossings shall be installed in 4-inch diameter Schedule 40 PVC pipe and color-coded blue. Service line crossings shall also be marked with magnetic tape or 12 gauge copper tracer wire.

2.06 SERVICE METERS

- A. Meters shall be furnished and set by Van Buren Municipal Utilities upon payment of the meter set fee. Meters shall be set in the meter setter and meter box installed by the Contractor.

2.07 SERVICE METER BOXES AND SETTERS

- A. Meter boxes shall be plastic with a heavy duty plastic lid unless otherwise noted on the Drawings or as specified below. Meter boxes shall be by DFW Plastics, Inc. or approved equal. The heavy duty plastic lid shall be by DFW Plastics, Inc. with a touch read pad space or approved equal. The words "WATER METER" shall be cast or molded into the lid.
- B. Meter boxes installed in sidewalk and light traffic areas shall be as follows:
 - 1. 5/8" x 3/4" meters: Ford Yoke Box part number YM 241-233-T with Cast Iron Locking Lid and 2-inch hole for touch read pad or approved equal,
 - 2. 1" meters: Ford Yoke Box part number YLB141=444=NL-T with Cast Iron Locking Lid and 2-inch hole for touch read pad or approved equal,
- C. For 1-1/2" and 2" meters in paved areas and sidewalks: DFW Meter Pit Part No. DFW-3636-DR-36"x36" plastic meter pit or approved equal with East Jordan Ring and Lid part number – 2750 A AHTD – Reversible Ring.
- D. For 5/8" x 3/4" to 2" meters in heavier traffic areas: DFW Meter Pit Part No. DFW-3636-DR-36"x36" plastic meter pit or approved equal with East Jordan Ring and Lid part number – 2750 A AHTD – Reversible Ring.
- E. Meters shall minimally be 5/8" x 3/4" unless otherwise noted on the Drawings or in the proposal.
- F. Meter setters shall be installed in accordance with the manufacturer's recommendations and shall be Ford 70 Series Coppersetter or approved equal in the following sizes:
 - 1. For 5/8" x 3/4" meters: VB72-7W-41-33-NL
 - 2. For 1" meters: VB74-10W-41-44-NL
 - 3. For 1-1/2" meters: VBB76-12B-11-66-NL (By Prior Approval Only)

4. For 2" meters: VBB77-12B-11-77-NL (By Prior Approval Only)

- E. Material requirements and installation details for 3-inch and larger water meters shall be preapproved by VBMU. Minimally, 3-inch and larger meters require a concrete meter vault and bypass piping with isolation valves.

2.08 CORPORATION STOPS AND SERVICE SADDLES

- A. Corporation stops shall be 3/4 or 1-inch nominal size and shall be bronze with AWWA threads on inlet end. Outlet end shall be flared or compression. Corporation stops to be Ford F1000-3, F1000-4 or approved equal.
- B. Service saddle bodies shall be cast malleable or ductile iron or cast bronze, tapped for AWWA threads. A neoprene gasket shall be cemented in place to saddle body. The saddle shall have either a single or a double strap. Saddle straps shall be flattened to increase bearing surface on the pipe and shall be galvanized, cadmium plated, or stainless steel. For ductile iron pipe, the saddle shall be Smith-Blair 313 (double bale) or approved equal. For C-900 PVC pipe, the saddle shall be Ford S90 or approved equal.
- C. When indicated on the Drawings, curb stops shall be Ford B-43-232W-NL (for 5/8" x 3/4" meters), B-43-444W-NL (for 1" meters) or approved equal.

2.09 MISCELLANEOUS FITTINGS

- A. Couplings for joining sections of pipe shall be manufactured of gray cast iron in accordance with ASTM A48. Flanges may be of malleable iron conforming to ASTM A48 or of ductile iron conforming to ASTM A536. Gaskets shall be of a permanent and set resistance material. Bolts shall conform to AWWA C111.
- B. Adapters for connecting pipes of dissimilar materials shall be manufactured of gray cast iron in accordance with ASTM A48. Flanges may be of fine-grained malleable iron conforming to ASTM A48 or of ductile iron conforming to ASTM A536. Gaskets shall be of a natural rubber compound that will provide permanence and resistance to set. Bolts for adapters shall be high strength steel or iron and shall be galvanized.
- C. Repair clamps shall be made of stainless steel Type 302 or 304, or of gray iron conforming to ASTM A48. Gaskets shall be of a natural rubber compound that will provide permanence and resistance to set. Bolts and nuts shall be high strength steel or iron and shall be coated and treated for corrosion protection. Repair clamps shall be of full circle design and shall have adequate length to properly repair line defects and thereby prevent future leakage at the repaired point.
- D. Miscellaneous fittings and adapters for service lines shall be wrought copper, cast bronze or brass conforming to the applicable sections of NSF Standard 61, NSF Standard 372, and the federal Public Law 111-380 "Reduction of Lead in Drinking Water Act". The supplying manufacturer shall provide certification indicating compliance.

2.10 TRACER WIRE

- A. All non-metallic pipe installed for mains shall be laid with tracer wire. Tracer wire shall be AWG TDW #12 solid copper and installed in a continuous non-interrupted circuit. Tracer wire junction boxes shall be installed at intervals shown on the Drawings, but not exceeding 1,000 feet unless specifically authorized by the Engineer.

2.11 CONCRETE

- A. Concrete shall have a compressive strength of not less than 2,500 psi, unless noted otherwise.

2.12 GRAVEL BEDDING

- A. The granular fill used as gravel bedding shall be crushed stone, crushed gravel, or gravel. The materials shall be well graded containing several sizes of particles ranging from 3/4-inch maximum to No. 4. Unless otherwise approved by the Engineer, the material shall meet the gradation requirements of ASTM C33, Gradation 67.

2.13 POLYETHYLENE ENCASEMENT (PIPE WRAP)

- A. Polyethylene encasement shall be a high-density, cross-laminated polyethylene film with a minimum thickness of 0.008 inches (8 mils) and conforming to AWWA C105. The film shall be black with 2 percent (2%) carbon black, be weather-resistant, and have product markings as defined in AWWA C105. Polyethylene encasement shall be furnished in either flat tube or sheet form.
- B. Tape for installation of polyethylene encasement on pipe and fittings and for the field repair of missing or damaged film shall be suitable for use with polyethylene, a minimum of 2 inches wide, and have a minimum thickness of 0.010 inches (10 mils). Tape shall be Polyken #900 Utility Pipeline Tape, Scotchrap 50 All-Weather Corrosion Protection Tape, or approved equal. Duct tape is not permitted.
- C. Store polyethylene encasement material in accordance with the manufacturer's instructions and in such a manner that it is not exposed to direct sunlight. Exposure during installation shall not exceed forty-eight (48) hours.

PART 3 EXECUTION

3.01 TRENCH EXCAVATION AND BACKFILL

- A. General: Refer to Section 210, Trenching and Backfill.

3.02 PIPE INSTALLATION

- A. General: Unload pipe, fittings and accessories near the place where they are to be laid in the trench, and handle with care to avoid damage. Cutting of pipe shall be done by means of an approved type of mechanical cutter.
- B. Placement of Pipe:
 - 1. Clean and inspect all sections of pipe, fittings and accessories for damage immediately prior to placement in the trench. Reject all defective materials and remove them from the project. Place pipe, fittings and accessories in the trench, and position them utilizing hoisting equipment. Lay pipe true to line and grade, with uniform bearing under the full length of the pipe barrel.
 - 2. Connect pipe joints and fittings in accordance with the pipe manufacturers' recommendations. Gaskets and lubricants shall be the type recommended by the pipe

manufacturer. Insert the spigot end of the pipe into the bell to the required depth and in such manner as to avoid displacement of the gasket. Jointing of mechanical-joint pipe shall be accomplished such that the gland is positioned evenly by tightening alternately the bolts spaced 180 degrees apart.

3. At times when pipe laying is not in progress, close the open ends of the pipe with a watertight plug. This provision shall apply during the lunch period, overnight, or any other time when work is not in progress.
4. No pipe shall be laid in wet trench conditions that preclude proper bedding, or on a frozen trench bottom, or when in the opinion of the Engineer, the trench conditions or the weather are unsuitable for proper installation.

C. Concrete Thrust Blocking

1. Install concrete thrust blocking at pipe bends, tees, fire hydrants, and other locations shown on the Drawings. Place the concrete between solid ground and the fitting to be anchored. Care shall be taken to place the thrust block such that the pipe and fitting joints will be accessible for repair.
2. The shape and contact area of the concrete thrust blocks shall be as shown on the Drawings and as directed by the Engineer. The contact area of backing shall be as required to prevent movement of the joint, but in no case shall the contact area be less than one square foot.

D. Connections to Mains

1. Connect new water mains to existing mains as shown on the Drawings.
2. Prior to valving off the existing main, assemble all equipment and fittings before excavating and exposing the main. Coordinate closing and opening of valves with VBMU. Connect to the new main using adapters and fittings specified. Bedding, backfilling, concrete blocking and other related items shall be as specified in other sections of this specification.
3. The main shall be connected and a corporation stop installed near the point of connection to permit expelling air from the line. Installation of the tap shall be as directed by the Engineer.

E. Installation of Polyethylene Encasement

1. When noted on the Drawings or in the bid proposal, place polyethylene encasement, either in tube or sheet form, around all buried cast or ductile iron pipe joints and fittings, valves, fire hydrants, tapping saddles, sleeves, couplings, and any other appurtenance with exposed bolts.
2. Install polyethylene encasement in accordance with AWWA C105 by personnel trained in the proper application of encasement. Install polyethylene tubing in accordance with either Method A or B, and polyethylene sheets in accordance with Method C. Install tape in accordance with AWWA C105 and the Polyethylene Encasement Installation Guide published by the Ductile Iron Pipe Research Association (DIPRA).
3. Provide adequate padding of encased pipe joints and fittings when lifting with tongs, cables, or chains to prevent damage to the polyethylene material.

4. Repair any rips, punctures, or other damage to the polyethylene film with tape or with a short length of polyethylene sheet or tube cut open, wrapped around the pipe to cover the damaged area, and secured in place with tape.

3.03 SERVICES

A. Service Taps and Service Lines

1. Service taps shall be made by installation of corporation stops and service saddle on the water mains. Taps shall be made at an approximate forty-five degree (45°) angle from the vertical.
2. Place service lines to the line and grade shown on the Drawings or as established by the Engineer. Place service lines at right angles to the water main. Lay service lines to a minimum depth of 18 inches below the finish ground surface, except at street crossings where the minimum cover below subgrade shall be 30 inches. Full lengths of tubing shall be used; no splices shall be installed between the service tap and the water meter.
3. The trench shall have a minimum width of 6 inches and a trench bottom free of rocks or boulders. The bottom of the trench shall be flat, smooth and even to provide a surface with a uniform bearing for the pipe.
4. If rock is encountered in the bottom of the trench, it shall be removed and a minimum bedding depth of 4 inches provided between the trench bottom and the service line pipe. Fill the excavated area below the grade line with sand or select material free of rocks, boulders, debris of any kind, or other objectionable matter, or material that may be injurious to the pipe. Tamp the bedding material prior to installation of the pipe.
5. Place and tamp the backfill material in layers not exceeding 4 inches in thickness. Use only backfill material that is free from stones, rocks, and clods and is not frozen. Tamp the backfill uniformly along the full length of the pipe to a point 4 inches (minimum) above the top of the pipe. The backfill densities shall be the same as those specified in other Sections of the specifications depending upon the location of the service line.
6. Service lines extending beneath existing pavements, which are to remain in place, shall be installed by boring or other subsurface method. The method used shall be approved by the Engineer and shall be a method that will avoid subjecting the service tubing to excessive stress. If obstructions are encountered and installation of a service line cannot be accomplished by boring, the service line shall be installed by the open trench method. Cutting and replacement of existing pavements shall be as specified in Section 220, Pavement Repairs and as shown on the Drawings.
7. Tubing shall be connected using the specified fittings and in such a manner to avoid excessive stress on the line.

B. Service Meter Boxes

1. Install meter boxes as shown on the Drawings and as approved and directed by VBMU. Unless otherwise noted, set meter boxes in the greenspace between the back of the street curb and the sidewalk, or at the customer's property line.
2. Contractor shall avoid installing meter boxes in driveways or sidewalks, or within 5 feet of any electrical or communication pedestal, electrical transformer, junction box, or other

hazardous appurtenance or obstruction. When installed adjacent to a sidewalk, the top of the box shall be flush with the sidewalk surface. Except as noted in the following paragraph, where a service meter box interferes with the installation of a sidewalk, the meter box must be relocated, or the sidewalk installed around the meter box.

3. VBMU will consider allowing meter boxes to be installed in sidewalks and in paved areas on a case-by-case basis, but the meter box shall be installed flush with the finished surface of the concrete or asphalt. See also paragraph 2.07.B for meter box requirements.
4. The meter and setter shall be approximately centered within the box. All meter boxes to have a station number, indicated on the Drawings, for location purposes.

3.04 STREET CROSSINGS

- A. Installation of water mains at street crossings shall be in open cuts unless boring is authorized in writing by the Engineer. Excavation, trenching, backfilling and pipe installation shall be as specified in Section 210, Trenching and Backfilling and as shown on the Drawings.
- B. Replacement of pavement shall be as specified in Section 220, Pavement Repairs and as shown on the Drawings. See Subsection 1.01 of Section 220 for additional city and state permitting and repair requirements. The surface of the replacement shall match the existing grade and shape of the pavement.
- C. The Contractor is responsible for obtaining all street crossing permits and repairing the pavement in accordance with the requirements of the City of Van Buren, Crawford County, or ARDOT.

3.05 DISINFECTION

- A. All materials, work, workmanship and methods shall be in accordance with the latest revision of the AWWA C651 – Disinfecting Water Mains.
- B. Samples of water shall be taken by the Contractor as directed by the Engineer and shall be submitted for analysis by the Arkansas Department of Health. A copy of the test results shall be furnished to the Engineer. A minimum of two (2) consecutive safe samples are required on each line section. Samples are to be collected on successive days.
- C. The disinfection procedures shall be repeated as necessary until all samples indicate that the water is safe and approved by the Arkansas Department of Health.

END OF SECTION 310 – WATER LINE IMPROVEMENTS

THIS PAGE LEFT BLANK INTENTIONALLY

SECTION 320 – WATER VALVES AND HYDRANTS

PART 1 GENERAL

1.01 SCOPE OF WORK

- A. Furnish all labor, materials, equipment and incidentals required to install all buried valves and valves in underground vaults, along with actuators and all accessories as shown on the Drawings and as specified herein.
- B. Coordinate the installation of all valves and hydrants with the City of Van Buren Municipal Utilities (VBMU), including water main taps, installation of valves and hydrants on existing water mains requiring interruption of water service to customers, and installation and functional field testing of water system control valves.

1.02 RELATED SECTIONS

- A. Section 210 – Trenching and Backfilling
- B. Section 310 – Water Line Improvements
- C. Section 330 – Testing of Water Line Improvements

1.03 REFERENCE STANDARDS

- A. American Society of Mechanical Engineers (ASME), latest edition:
 - 1. ASME B1.20.1 Pipe Threads, General Purpose (Inch)
- B. NSF International / American National Standards Institute / (NSF/ANSI), latest edition:
 - 1. NSF/ANSI Standard 61: Drinking Water System Components - Health Effects
 - 2. NSF/ANSI Standard 372: Drinking Water System Components - Lead Content
- C. American Society for Testing and Materials (ASTM), latest edition:
 - 1. ASTM A48 Standard Specification for Gray Iron Castings
 - 2. ASTM A126 Standard Specification for Gray Iron Castings for Valves, Flanges, and Pipe Fittings
 - 3. ASTM A153 Standard Specification for Zinc Coating (Hot-Dip) on Iron and Steel Hardware
 - 4. ASTM A276 Standard Specification for Stainless Steel Bars and Shapes
 - 5. ASTM A536 Standard Specification for Ductile Iron Castings
 - 6. ASTM D2000 Standard Classification System for Rubber Products in Automotive Applications

D. American Water Works Association (AWWA), latest edition:

1. AWWA C111 Rubber Gasket Joints for Ductile iron Pressure Pipe and Fittings
2. AWWA C502 Dry-Barrel Fire Hydrants
3. AWWA C509 Resilient-Seated Gate Valves for Water Supply Service
4. AWWA C512 Air-Release, Air/Vacuum, and Combination Air Valves for Waterworks Service
5. AWWA C542 Electric Motor Actuators for Valves and Slide Gates
6. AWWA C550 Protective Interior Coatings for Valves and Hydrants
7. AWWA C600 Installation of Ductile Iron Water Mains and Their Appurtenances
8. AWWA C651 Disinfecting Water Mains
9. AWWA C900 Polyvinyl Chloride (PVC) Pressure Pipe and Fabricated Fittings, 4 In. Through 12 In. (100 mm Through 300 mm), for Water Transmission and Distribution

E. Steel Structures Painting Council (SSPVC), latest edition:

1. SSPC SP-6 Surface Preparation Specification No. 6 Commercial Blast Cleaning

1.04 SUBMITTALS

- A. Material and Equipment Submittals: Submit to the Engineer for review all information required to establish compliance with these Specifications. Submittals shall include the following:
1. Manufacturer's literature, illustrations, specifications and engineering data including dimensions, sizes, construction materials, valve and actuator weights, and protective coatings.
 2. Where applicable or as requested by the Engineer, submit calculations for actuator torque and actuator wiring details including ladder diagrams and point-to-point wiring.
- B. Test Reports: Submit four (4) copies of all certified shop test results specified herein.
- C. Operation and Maintenance Manuals: Submit one (1) hard copy of each O&M manual on paper plus one (1) electronic copy in indexed PDF format. O&M manuals shall include copies of all approved Shop Drawings. Submit manuals in three-ring binders with reinforced punched page edges and with spine and cover title information.
- D. Certificates: Prior to shipment of valves and accessories, submit a certified affidavit of compliance from the manufacturer stating that all valves for this project have been manufactured and tested in accordance with AWWA and ASTM standards. Submit certified testing results and certification of proper installation.

1.05 QUALITY ASSURANCE

- A. Manufacturer's Qualifications:
 - 1. Valves and appurtenances provided under this Section shall be the standard product in regular production by manufacturers whose products have proven reliable in similar service for at least five (5) years. If required, the manufacturer shall furnish evidence of installation in satisfactory operation.
 - 2. All units of the same type shall be the product of one (1) manufacturer.
- B. Design Criteria: All valves and appurtenances shall be new and in perfect working condition. Valves shall be designed for continuous use with a minimum of maintenance and service required and shall perform the required function without exceeding the safe limits for stress, strain or vibration. In no case will used or damaged valves be acceptable. The selection of equipment to meet the specified design conditions is the responsibility of the Contractor. Both workmanship and material shall be of the very best quality and shall be entirely suitable for the service conditions specified.
- C. Source Quality Control
 - 1. Shop test valves in accordance with the referenced AWWA or other standard.
 - 2. Obtain each type of valve from no more than one (1) manufacturer.

1.06 DELIVERY, STORAGE AND HANDLING

- A. Store all equipment in covered storage off the ground.
- B. Protect threads and seats from corrosion and damage. Coat rising stems and exposed stem valves with a protective oil film and maintain coatings until time of use.
- C. Furnish covers for all openings.
 - 1. All valves 3-inch and larger shall be shipped and stored on site until time of use with wood or plywood covers on each valve end.
 - 2. All valves smaller than 3-inch shall be shipped and stored as above except that heavy cardboard covers may be furnished instead of wood.
- D. Store equipment to permit easy access for inspection and identification. Any corrosion in evidence at the time of acceptance by VBMU shall be removed, or the valve shall be removed from the job.

PART 2 PRODUCTS

2.01 GENERAL

- A. All buried valves shall open counter-clockwise.
- B. The use of a manufacturer's name and/or model or catalog number is for the purpose of establishing the standard of quality and general configuration desired.
- C. Valves shall be of the size shown on the Drawings or as noted and as far as possible, equipment of the same type shall be identical and from one (1) manufacturer.
- D. Valves shall have the name of the maker, nominal size, flow directional arrows, working pressure for which they are designed and standard to which they are manufactured cast in raised letters on some appropriate part of the body.
- E. Valves shall be rated for the adjoining piping system pressures as indicated on the Drawings. Unless otherwise noted, valves shall have a minimum working pressure as designated below or be of the same working pressure as the pipe they connect to, whichever is higher, and suitable for the pressures noted where they are installed.
 - 1. 3 to 12-inch diameter: 200 psi.
 - 2. 14 to 36-inch diameter: 150 psi.
- F. Valves shall be of the same nominal diameter as the pipe or fittings to which they are connected. Except as otherwise noted, joints shall be mechanical joints, with joint restraint where the adjacent piping is required to be restrained.
- G. Valves shall be especially constructed for buried service.
- H. Valves and hydrants shall conform to the applicable sections of NSF Standard 61, NSF Standard 372, and the federal Public Law 111-380 "Reduction of Lead in Drinking Water Act". The supplying manufacturer shall provide certification indicating compliance.
- I. Contractor shall successfully demonstrate the proper operation of all valves prior to acceptance.

2.02 VALVE BOXES

- A. Valve boxes shall be of the cast iron extension type. Boxes may be screw type, with a lap of 6 inches when in the most extended position. Lids shall be marked with the inscription "WATER" cast into the top, and bases shall be of the proper size for the valve. Aluminum or plastic covers are not acceptable. A means of lateral support for the valve extension shaft shall be provided in the top portion of the valve box.
- B. The boxes tops, extensions and bottoms shall be similar and equal to Tyler Union two (2) Piece Valve Box Series 6850 or Three-Piece Valve Box Series 6860, screw-type, with 5 1/4-inch shaft. Valve boxes shall have one (1) priming coat and two (2) coats of coal tar paint.
- C. The upper section of each box shall have a bottom flange of sufficient bearing area to prevent settling. The bottom of the lower section shall enclose the stuffing box and operating nut of the valve and shall be oval.

- D. Valve box risers shall be similar and equal to Tyler Union #69 Screw Type or Slip Type Adjustable Riser. Fixed type risers shall accommodate the original valve box lids, and adjustable type risers shall be furnished with new lids. The Contractor is responsible for correctly sizing risers to fit existing valve boxes and lids.
- E. Contractor shall avoid installing valve boxes in driveways or sidewalks, or within 5 feet of any electrical or communication pedestal, electrical transformer, junction box, or other hazardous appurtenance or obstruction. When installed adjacent to a sidewalk or driveway, the top of the box shall be flush with the concrete or asphalt surface. Except as noted in the following paragraph, where a valve box interferes with the installation of a sidewalk or driveway, the valve and valve box must be relocated, or the sidewalk or driveway must be installed around the valve box.
 - 1. VBMU will consider allowing valve boxes to be installed in sidewalks and driveways on a case-by-case basis, but the valve box shall be installed flush with the finished concrete or asphalt surface.
 - 2. The location of all distribution system isolation valves and valve boxes shall be approved by VBMU.
- F. When noted on the Drawings, buried valves shall be provided with extension shafts, operating nuts and valve boxes as follows:
 - 1. Valve extension shafts shall be Type 304 stainless steel and the operating nut shall be 2 inches square. Shafts shall be designed to provide a factor of safety of not less than four. The extension shall include a box wrench, 1-1/8 inches square, made from 3/16-inch stainless steel and welded to the lower end of the stem extension and which will fit over the valve's operating nut.
 - 2. Valve operating nuts shall be pinned to the shafts (box wrench). All fasteners shall be Type 304 stainless steel. Welds on stem extensions (top and bottom nut) shall be 1/8-inch to 3/16-inch fillet weld around full circumference.
 - 3. Install a round center guide made from 1/8-inch or 3/16-inch steel plate on the valve stem extension approximately 6 inches from the upper end. The diameter of the guide shall be slightly less than the inside diameter of the valve box. The guide shall be affixed to the stem extension in such a way that it can rotate freely on the stem.
 - 4. Top of the operating nut shall be located 12 to 24 inches below the rim of the valve box.

2.03 GATE VALVES

- A. General:
 - 1. Unless otherwise approved, all gate valves, 3 inches and larger, shall be resilient seated gate valves conforming to the requirements of AWWA C509.

- B. Gate valves 2-inch diameter and smaller:
 - 1. FIPT x FIPT, Ductile Iron, Non-rising stem, 2-inch square operating nut, with minimum non-shock working pressure of 150 psi,
 - 2. Valves shall be AVK Model 03-063-TNN, CLOW C509, or approved equal,
 - 3. Valves smaller than 2-inch diameter shall be reviewed on a case-by case basis.

2.04 RESILIENT SEATED GATE VALVES

- A. Resilient seated gate valves shall be of cast iron or ductile iron, bronze mounted, with mechanical joints, a non-rising stem, and 2-inch AWWA operating nut. Valves shall be manufactured in accordance with AWWA C509 and shall be Mueller A-2360-20 or A-2361-20 or approved equal. Unless otherwise noted, resilient seated gate valves shall be rated for the following minimum working pressures:
 - 1. 3 to 12-inch diameter: 200 psi,
 - 2. 14 to 36-inch diameter: 150 psi.
- B. Valves shall be provided with a minimum of two (2) O-ring stem seals.
- C. Bonnet and gland bolts and nuts shall be either fabricated from a low alloy-steel for corrosion resistance or electroplated with zinc or cadmium. The hot-dip process in accordance with ASTM A153 is not acceptable.
- D. Wedges shall be totally encapsulated.
- E. Units shall be UL and FM approved.
- F. The valve manufacturer shall furnish an affidavit that the gate valves have been manufactured and tested in accordance with AWWA C509.

2.05 TAPPING SLEEVES AND TAPPING VALVES

- A. Tapping sleeves shall be Smith-Blair Model 663 or approved equal. Tapping sleeve shall have a Type 304 stainless steel body with circumference rubber gasket rated for water service and conforming to ASTM D2000. Sleeves shall be rated for 250 psi service (4-inch to 8-inch), 200 psi service (10-inch to 24-inch), or 150 psi service (26-inch to 30-inch). Stainless steel sleeves with iron tapping flanges are not acceptable. All hardware shall be Type 304 stainless steel.
- B. Field verify existing water line type and pipe O.D. before ordering the tapping sleeve. The location of tapping sleeves shall be approved by VBMU.
- C. Include a 3/4-inch NPT test plug, and pressure test the sleeve in the presence of the Engineer or a representative of VBMU before commencing tap.
- E. Tapping valves shall conform to the requirements specified above for resilient seated gate valves except that one (1) end shall be flanged and one (1) mechanical. Tapping valves shall be provided with an oversized opening to permit the use of full size cutters. Tapping valves shall be Mueller T-2360 or approved equal.

- F. The valve manufacturer shall furnish an affidavit that the tapping valves have been manufactured and tested in accordance with AWWA C509.

2.06 MAIN LINE PRESSURE REDUCING VALVES

- A. Pressure reducing valves for main water lines shall be Model 90-48 as manufactured by Cla-Val Company, or an approved equal. The pressure reducing valve shall incorporate a low-flow bypass, X46A flow clean strainer, X43 “Y” strainer, and isolation valves. The discharge pressure shall be set as shown on the Drawings.
- B. Unless otherwise noted on the Drawings, main line pressure reducing valves shall be installed in a concrete vault.

2.07 FIRE HYDRANTS

- A. Fire hydrants shall be three-way with two (2) hose nozzles and one (1) pumper nozzle, similar and equal to Mueller Super Centurion 250 Fire Hydrant, Catalog No. A-423. Hydrants shall be furnished with a mechanical joint base shoe, and all fittings shall be anchor type. Unless otherwise indicated on the Drawings, the inlet connection shall be 6-inch diameter.
- B. Hydrants shall have incorporated in their design, a breakable connection feature including a safety stem coupling immediately above the bury line. This breakable connection shall have a lower breaking strength than the remainder of the unit.
- C. Hydrants shall be furnished and set for a minimum depth of cover of 42 inches unless otherwise indicated on the Drawings. Provide the appropriate fire hydrant extension necessary to place the centerline of the pumper nozzle a minimum of 18 inches above finished grade. Where fire hydrant extensions are required, they shall be of the proper design to accommodate the make of fire hydrant installed.
- D. The hydrant manufacturer shall furnish an affidavit that the fire hydrants have been manufactured and tested in accordance with AWWA C502.
- E. Contractor shall avoid installing fire hydrants or their watch valves and boxes in sidewalks or driveways, or within 5 feet of any electrical or communication pedestal, electrical transformer, junction box, or other hazardous appurtenance or obstruction. When installed adjacent to a sidewalk, the top of the watch valve box shall be flush with the sidewalk surface. Except as noted in the following paragraph, where a fire hydrant interferes with the installation of a sidewalk, the hydrant and watch valve must be relocated, or the sidewalk installed around the fire hydrant.
 - 1. VBMU will consider allowing the watch valve to be installed in a sidewalk or a driveway on a case-by-case basis, but the valve box shall be installed flush with the finished concrete or asphalt surface. In no case shall a fire hydrant be installed in a sidewalk or driveway.
 - 2. Fire hydrants installed in parking lots or immediately adjacent to driveways shall include the installation of steel traffic bollards to protect the hydrant.
 - 3. The location of fire hydrants and traffic bollards shall be approved by VBMU.
- F. Field paint hydrants and traffic bollards with a yellow color as approved by VBMU.

2.08 FLUSHING HYDRANTS

- A. Flushing hydrants shall be of the non-freezing type with a 2-inch hose nozzle and a 2-inch FIP inlet. Flushing hydrants shall be set at the locations as shown in the Drawings and shall have a depth of bury that will meet the elevations given in the Drawing or a depth of 30 inches, whichever is greater. The hydrant shall have a locking operating rod and shall be serviceable from above grade. Flushing hydrants shall be Eclipse Model No. 77 Mainguard Hydrant as manufactured by the Kupferle Foundry Company.
- B. Contractor shall avoid installing flushing hydrants or their isolation valves and boxes in sidewalks or driveways, or within 5 feet of any electrical or communication pedestal, electrical transformer, junction box, or other hazardous appurtenance or obstruction. When installed adjacent to a sidewalk, the top of the isolation valve box shall be flush with the sidewalk surface. Except as noted in the following paragraph, where a flushing hydrant interferes with the installation of a sidewalk, the hydrant and isolation valve must be relocated, or the sidewalk installed around the flushing hydrant.
 - 1. VBMU will consider allowing the isolation valve to be installed in a sidewalk or a driveway on a case-by-case basis, but the valve box shall be installed flush with the finished concrete or asphalt surface. In no case shall a flushing hydrant be installed in a sidewalk or driveway.
 - 2. The location of flushing hydrants shall be approved by VBMU.

2.09 ALTITUDE VALVE

- A. Altitude valves shall be suitable for two (2) way flow and shall be Cla-Val Model 210-16 or approved equal.

2.10 MISCELLANEOUS FITTINGS

- A. Miscellaneous fittings and adapters for service lines shall be wrought copper, cast bronze or brass conforming to the applicable sections of NSF Standard 61, NSF Standard 372, and the federal Public Law 111-380 "Reduction of Lead in Drinking Water Act." The supplying manufacturer shall provide certification indicating compliance.

2.11 SURFACE PREPARATION AND SHOP COATINGS

- A. Except for finished or bearing surfaces, the interior ferrous metal surfaces for potable water service valves shall be blast cleaned in accordance with SSPC SP-6 and painted with a minimum of 10 mils of a fusion epoxy coating formulated for potable water use, similar and equal to Pro-Gard epoxy by Mueller. The coating used must comply with AWWA C550, be certified to NSF 61, and appear on the current edition of the United States Environmental Protection Agency's list entitled "Accepted Categories and Subcategories of Coating, Liners and Paints for Potable Water Usage".
- B. Exterior ferrous metal surfaces of all buried valves and hydrants shall be blast cleaned in accordance with SSPC SP-6 and given two (2) shop coats of a heavy coal tar enamel or approved two-component coal tar epoxy paint. Gate valves shall be coated with fusion epoxy in accordance with the interior coating requirements described above.

PART 3 EXECUTION

3.01 INSPECTION AND PREPARATION

- A. During installation of all valves and appurtenances, verify that all items are clean, free of defects in material and workmanship and function properly.
- B. All valves shall be closed and kept closed until otherwise directed by the Engineer and VBMU.

3.02 INSTALLATION OF BURIED VALVES AND VALVE BOXES

- A. Buried valves shall be cleaned and manually operated before installation. Buried valves and valve boxes shall be set with the stem aligned in true vertical position and in the center of the valve box. Valves shall be set on a firm foundation and supported by tamping pipe bedding material under the sides of the valve.
- B. The valve box shall be supported during backfilling and maintained in vertical alignment with the top flush with finish grade. Earth fill shall be carefully tamped around each valve box for the full excavation depth and for a distance of not less than 4 feet on all sides of the box, or to the undisturbed wall of the trench if less than 4 feet. The valve box shall be set so as not to transmit traffic loads to the valve.
- C. Before backfilling, all exposed portions of any bolts shall be coated with two (2) coats of a polyamide epoxy-coal tar paint, similar and equal to Series 46H-413 Hi-Build Tneme-Tar by Tnemec Co., Inc.
- D. Install a 2' x 2' x 4" (minimum) concrete collar, utilizing 3,000 psi fiber-reinforced concrete, around each new valve box located outside of pavement surfaces or sidewalks and around all valve boxes that have been modified or replaced. Precast concrete collars are not permitted.
- E. Install valve boxes in pavement areas to receive asphalt or concrete paving prior to the start of surfacing operations. Adjust valve boxes in designated reconstruction areas prior to placement of the final pavement surfacing. Set boxes level with the new roadway grade and cross slope. Repair any structural damage to the pavement section due to Contractor's negligence at no additional cost to VBMU.
- F. Where designated on the Drawings, remove and replace existing valve boxes with new boxes and lids of the type specified in this Section. Install box extensions as necessary to obtain the specified grade. Install compacted backfill around boxes as specified above. Existing valve boxes shall be salvaged and delivered to VBMU.

3.03 INSTALLATION OF TAPPING SLEEVES AND VALVES

- A. Contact VBMU and obtain permission to tap any "live" water line. Follow all procedures and timetables required by VBMU.
- B. Installation of tap shall be made under pressure, and flow through the existing water line shall be maintained. The diameters of the tap shall be a minimum of 1/4-inch less than the inside diameter of the branch line.

- C. The entire operation shall be conducted by workers experienced in the installation of tapping sleeves and valves. Unless otherwise noted on the Drawings, the tapping machine shall be furnished by the Contractor.
- D. Determine the location of the line to be tapped to confirm that the proposed location will be satisfactory, and that no interference will be encountered such as joints or fittings. No tap or sleeve will be made closer than three feet from a pipe joint.
- E. Set the tapping sleeve and valve with its box squarely centered on the line to be tapped. Provide adequate support under the sleeve and valve during the tapping operation. Install a concrete pad under the valve as noted on the Drawings. Install thrust blocks or other permanent restraint acceptable to the Engineer behind all tapping sleeves. Proper tamping of supporting pipe bedding material and backfill around and under the valve and sleeve is mandatory for buried installations.
- F. After completing the tap, flush the valve to ensure that the valve seat is clean. Follow all testing and disinfection procedures as described in Section 310, Water Line Improvements and AWWA C651.

3.04 INSTALLATION OF FIRE HYDRANTS

- A. Install fire hydrants at the locations indicated on the Drawings or as directed by VBMU or the Engineer. Install all hydrants plumb with their nozzles parallel with or at right angles to the curb, and with the pumper nozzle facing the curb. Install hydrants at the established grade, with nozzles 18 inches (minimum) to 24 inches (maximum) above the ground.
- B. Unless otherwise indicated on the Drawings, connect each hydrant to the main with a 6-inch ductile iron pipe branch and a 6-inch gate (watch) valve to provide independent control of the hydrant.
- C. Tie each hydrant shoe to the main with approved restrained joints. Install concrete blocking behind the shoe so that the drains and fitting joints are accessible.
- D. Provide a drainage pit at each fire hydrant with 3 cubic yards of 1/2-inch washed gravel conforming to ASTM C33.

3.05 FIELD TESTS AND ADJUSTMENTS

- A. Conduct a functional field test of each valve in the presence of the Engineer and a representative of VBMU to demonstrate that each part of all components functions together correctly. All testing equipment required shall be furnished by the Contractor.

3.06 MANUFACTURER'S SERVICE

- A. Furnish the services of an operator certified or trained by the tapping equipment manufacturer to provide on-site instruction during wet tapping of the existing water mains indicated on the Drawings.

END OF SECTION 320 – WATER VALVES AND HYDRANTS

SECTION 330 – TESTING OF WATER LINE IMPROVEMENTS

PART 1 GENERAL

1.01 SCOPE OF WORK

- A. Furnish all labor, materials, tools, equipment and related items required to perform pressure and leakage testing of pressure pipelines.
- B. Coordinate all testing of water lines with the City of Van Buren Municipal Utilities (VBMU), including operation of isolation valves and hydrants, pressure testing, disinfection and system flushing, and sampling for bacteriological testing.

1.02 RELATED SECTIONS

- A. Section 310 – Water Line Improvements
- B. Section 320 – Water Valves and Hydrants

1.03 REFERENCE STANDARDS

- A. American Water Works Association (AWWA), latest edition:
 - 1. AWWA C600 Installation of Ductile Iron Water Mains and Their Appurtenances

PART 2 PRODUCTS

2.01 WATER FOR TESTING

- A. VBMU will provide water for the testing of pipelines. Notify VBMU 24 hours prior to scheduling the water line testing. VBMU may elect to install a flow meter at a fire hydrant or on an existing water main adjacent to the project site for the Contractor's use, and the Contractor is responsible for all additional piping, valves and other connection appurtenances. Excessive or wasteful usage of water shall not be tolerated. Water valves on the existing water distribution system may only be operated by VBMU personnel.

PART 3 EXECUTION

3.01 GENERAL

- A. Conduct hydrostatic pressure and leakage tests on all pressure pipelines carrying water.
- B. Furnish all labor and equipment, including test pump with regulated bypass meters and gauges, required for conducting pipeline tests. Furnish equipment and necessary piping as required to transport water used in testing from source to test location.
- C. Schedule time and sequence of testing, subject to observation and approval by VBMU and the Engineer. Provide adequate labor, tools and equipment to operate valves. Coordinate all valve operation with VBMU. Locate and repair any leaks discovered during the initial filling of the pipeline or during the course of the tests.

3.02 CLEANING

- A. At the conclusion of the work, thoroughly clean all pipelines by flushing with water to remove all dirt, stones, pieces of wood, or other material that may have entered the pipes during the construction period. Remove debris cleaned from the lines from the low end of the pipeline.

3.03 TEST PROCEDURES WATER LINE

A. General

- 1. After laying pipe and consolidating backfill, subject all newly laid pipe or any isolated section thereof, to hydrostatic pressure testing. Conduct the pressure testing for the duration as described below, unless otherwise specified or noted on the Drawings. Disconnect all meters, fixtures, devices or appliances that are connected to the pipeline system, and which might be damaged if subjected to the specified test pressure. Plug or cap the ends of branch lines during the testing procedures.
- 2. Fill each isolated (capped or plugged) section of pipe slowly with water and expel all air. If permanent air vents are not located at all high points, install corporation or blow-off cocks at such points to expel air as filling takes place. After expelling all air, close the cocks and keep the pipe filled until tested. Examine all exposed pipe, fittings, valves, hydrants and joints while under test pressure, and repair all visible leaks. Remove and replace any cracked or defective pipe, fittings, valves or hydrants discovered during testing. Replace the damaged pipe or appurtenances and repeat the testing to the satisfaction of VBMU.

- B. Do not conduct hydrostatic pressure testing until at least five (5) days have elapsed after installation of concrete thrust blocking. Do not conduct testing until at least two (2) days have elapsed for thrust block concrete containing high-early-strength cement.

C. Hydrostatic Leakage Tests

- 1. Leakage shall be defined as the quantity of water that must be supplied into the newly laid pipe, or any isolated section thereof, to maintain the specified leakage test pressure after the air in the pipeline has been expelled and the pipe has been filled with water.
- 2. Determine leakage by recording the quantity of water pumped into the pipeline through a standard water meter of a size appropriate to secure an accuracy of $\pm 2\%$ at the average flow rate pumped. The Engineer must approve other methods of measuring the quantity of water pumped prior to commencing the hydrostatic test. Pressurize the pipeline to a least 50-percent (50%) above normal operating or working pressure of the system, but never less than 150 psi. Maintain the test pressure for a period of two (2) hours.
- 3. Calculate allowable leakage in accordance with AWWA C600 and as determined by the formula:

$$L = \frac{S * D * \sqrt{P}}{133,200}$$

Where: L = the allowable leakage, in gallons per hour
S = the length of pipeline tested, in feet
D = the nominal diameter of the pipe, in inches
P = the average test pressure during the leakage tests, in psi gauge

4. In the event any section of the tested line fails to meet the above specified requirements for water tightness, determine and remedy the cause of the excessive leakage at no additional cost to VBMU, including retesting if required.

3.04 FINAL ACCEPTANCE

- A. VBMU will not accept the completed water line until the Contractor has repaired all known leaks, whether or not leakage is within allowable limits. Locate and repair all leaks at no additional cost to VBMU.
- B. The Engineer shall certify successful completion of all required pressure and leakage tests before the pipeline will be accepted by VBMU.
- C. Prior to acceptance, all public (city) fire hydrants shall be tested by VBMU or the Van Buren Fire Department for fire flow capacity.

END SECTION 330 – TESTING OF WATER LINE IMPROVEMENTS

THIS PAGE LEFT BLANK INTENTIONALLY

SECTION 410 – SANITARY SEWER LINE IMPROVEMENTS

PART 1 GENERAL

1.01 SCOPE OF WORK

- A. Furnish all labor, materials, equipment and incidentals required to install and test sanitary sewer lines, services, and all appurtenances.
- B. Coordinate all sanitary sewer line work with the City of Van Buren Municipal Utilities (VBMU), including sewer service taps, connections to existing sewer mains requiring interruption of sewer service to customers, installation and operation of bypass pumping, operation of sewage pumping stations, pressure and deflection testing of sewer mains, and installation and connection of sanitary sewer services.

1.02 RELATED SECTIONS

- A. Section 210 – Trenching and Backfilling
- B. Section 220 – Pavement Repair
- C. Section 230 – Site Restoration
- D. Section 420 – Sanitary Sewer Manholes
- E. Section 440 – Testing of Sanitary Sewer Improvements

1.03 REFERENCE STANDARDS

- A. American Society for Testing and Materials (ASTM), latest edition:
 - 1. ASTM C33 Standard Specification for Concrete Aggregates
 - 2. ASTM C1244 Standard Test Method for Concrete Sewer Manholes by the Negative Air Pressure (Vacuum) Test
 - 3. ASTM D1784 Standard Specification for Rigid Poly(Vinyl Chloride) (PVC) Compounds and Chlorinated Poly(Vinyl Chloride) (CPVC) Compounds
 - 4. ASTM D1785 Standard Specification for Poly(Vinyl Chloride) (PVC) Plastic Pipe, Schedules 40, 80, and 120
 - 5. ASTM D2241 Standard Specification for Poly(Vinyl Chloride) (PVC) Pressure-Rated Pipe (SDR Series)
 - 6. ASTM D2321 Standard Practice for Underground Installation of Thermoplastic Pipe for Sewers and Other Gravity-Flow Applications
 - 7. ASTM D2729 Standard Specification for Poly (Vinyl Chloride)(PVC) Sewer Pipe and Fittings

8. ASTM D3034 Specification for Type PSM Poly (Vinyl Chloride) (PVC) Sewer Pipe and Fittings
 9. ASTM D3212 Standard Specification for Joints for Drain and Sewer Plastic Pipes Using Flexible Elastomeric Seals
 10. ASTM F477 Standard Specification for Elastomeric Seals (Gaskets) for Joining Plastic Pipe
 11. ASTM F679 Standard Specification for Poly (Vinyl Chloride) (PVC) Large-Diameter Plastic Gravity Sewer Pipe and Fittings
 12. ASTM F949 Standard Specification for Poly (Vinyl Chloride) (PVC) Corrugated Sewer Pipe With a Smooth Interior and Fittings
- B. American Water Works Association (AWWA), latest edition:
1. AWWA C104 Cement-Mortar Lining for Ductile Iron Pipe and Fittings for Water
 2. AWWA C105 Polyethylene Encasement for Ductile iron Pipe Systems
 3. AWWA C110 Ductile iron and Gray-Iron Fittings
 4. AWWA C111 Rubber Gasket Joints for Ductile iron Pressure Pipe and Fittings
 5. AWWA C151 Ductile iron Pipe, Centrifugally Cast, For Water
 6. AWWA C600 Installation of Ductile Iron Water Mains and Their Appurtenances

1.04 SUBMITTALS

- A. Submit shop drawings and product data to the Engineer for review.
- B. When required by VBMU or the Engineer, submit a tabulated laying schedule that references stations and piping elevations as shown on the Drawings as well as all fittings, manholes, adapters, solid sleeves and specials, along with the manufacturer's drawings and specifications indicating complete details of all items. The laying schedule shall show pipe class, class coding, station limits and transition stations for various pipe classes. Submit laying schedule to the Engineer for approval before manufacture and shipment. The location of all pipes shall conform to the locations indicated on the Drawings.
- C. Prior to shipment of pipe, submit a certified affidavit of compliance from the manufacturer stating that the pipe, fittings, gaskets, linings and exterior coatings for this project have been manufactured and tested in accordance with ASTM and AWWA standards and requirements specified herein.

1.05 QUALITY ASSURANCE

- A. Provide all layout staking including establishing temporary benchmarks, alignment staking, and offset hubs. Submit a copy of the proposed sewer trench cut sheet to the Engineer for review purposes prior to commencement of work on any sewer segment.

- B. Provide equipment and labor necessary to verify proper vertical and horizontal alignment of all manholes and sewer pipe alignment 60 feet from each manhole. Submit written documentation of correct alignment, grades and elevations to the Engineer before proceeding with the sewer segment.
- C. Engineer may require additional checks of alignment, elevation and grades as necessary to verify the accuracy of the installation. Failure to achieve the vertical and horizontal alignment as specified on the Drawings shall be cause for rejection of the work, correction of which shall be at the Contractor's expense.
- D. Submit all testing documentation to the Engineer in accordance with the field testing requirements of this Section.
- E. The Engineer or other representative of VBMU may inspect the pipe and fittings after delivery. The pipe will be subject to rejection at any time because of failure to meet any of the Specification requirements, even though sample pipes may have been accepted as satisfactory at the place of manufacture. The Engineer or VBMU will mark pipe rejected after delivery for identification, and the Contractor shall remove the pipe from the project.
- F. Permanently mark all pipe and fittings with the following information:
 - 1. Manufacturer and date,
 - 2. Size, type, class, or wall thickness,
 - 3. Standard produced to (ASTM, AWWA, etc.).

1.06 DELIVERY, STORAGE AND HANDLING

- A. Comply with manufacturer's ordering instructions and lead time requirements to avoid construction delays.
- B. Exercise care in loading, transporting and unloading to prevent injury to the pipe or coatings. Under no circumstances shall pipe joints or fittings be dropped or skidded against each other. Use padded slings, hooks, or pipe tongs to prevent damage to the external surface coating or internal lining of the pipe.
- C. Store materials protected from damage and exposure to harmful weather conditions. Keep the interior of all pipe joints, fittings and other appurtenances free from dirt or foreign matter.
- D. Do not stack pipe higher than the limits recommended by the pipe manufacturer. Keep the bottom tier off the ground on timbers, rails or concrete.

1.07 COORDINATION

- A. Verify at the site both the dimensions and work of other trade's adjoining items of work in this Section before commencement of items specified herein.
- B. Do not disrupt service to utility customers during installation of the sanitary sewer improvements except for the time required to make connections to a new sewer.

- C. Notify VBMU and the Engineer at least 48 hours prior to scheduled connections of sewer. Scheduling shall be subject to the approval of VBMU and the Engineer.
- D. Work may proceed on one (1) or more sewer lines simultaneously; however, once work has commenced on any given line, continue that construction until its completion.
- E. Vary the sequence of construction as directed by the Engineer.

1.08 FIELD MEASUREMENTS

- A. Take field measurements at the site to verify or supplement indicated dimensions and to ensure proper coordination of all other construction items.

PART 2 PRODUCTS

2.01 GENERAL

- A. All materials shall conform to the standards referenced. All gasket and joint materials, lubricants, adhesives and other incidental materials shall conform to the pipe manufacturer's recommendations.
- B. Unless otherwise indicated on the Drawings, sewer lines and force mains that are larger than 12 inches in diameter or will be installed 8 feet or deeper from the proposed finished grade, shall be constructed of cement lined ductile iron pipe. All other sewer lines may be constructed of either cement lined ductile iron pipe or PVC pipe.

2.02 DUCTILE IRON PIPE

- A. Ductile iron pipe shall have push-on joints, cement lining, bituminous exterior coating, and conform to AWWA C104, C111 and C151. Unless otherwise noted on the Drawings or in the bid proposal, provide Class 350 pipe for 4-inch to 12-inch diameter, Class 250 for 14-inch to 24-inch diameter, and Class 150 for 30-inch diameter and larger in accordance with AWWA C150. Install polyethylene wrap where indicated on the Drawings or as indicated on the bid proposal.

2.03 POLYVINYL CHLORIDE (PVC) PIPE AND FITTINGS

- A. PVC solid wall gravity pipe and fittings shall be Type PSM, PVC SDR 35 with full diameter dimensions and shall conform to ASTM D3034 for sizes 4 through 12-inch diameter. Furnish straight pipe in lengths according to ASTM D3034 and furnish wyes in lengths of not more than 3 feet long. Saddle wyes will not be allowed.
- B. PVC pipe and fittings shall have bell and spigot push-on joints. The bell shall consist of an integral wall section with a solid cross-section elastomeric gasket securely locked in place to prevent displacement during assembly. Installation of elastomeric gasketed joints and performance of the joint shall conform to D3212 or ASTM F477. All PVC pipe shall have a Mega-Stop Series 5000 by EBAA Iron, or approved equal, installed on all joints to prevent the over-insertion of spigots.
- C. All fittings and accessories for sewers shall have bell and/or spigot configurations compatible with the pipe.
- D. Sewer piping shall be green in color. All sewer pipe and associated fittings shall be furnished by the same manufacturer unless otherwise approved by the Engineer.

PART 3 EXECUTION

3.01 INSTALLATION OF SEWER PIPE AND FITTINGS

- A. No single piece of pipe shall be laid unless it is straight. The centerline of the pipe shall not deviate from a straight line drawn between the centers of the openings at the ends of the pipe by more than 1/16-inch per foot of length. If a piece of pipe fails to meet this requirement check for straightness, it shall be rejected and removed from the site. Laying instructions of the manufacturer shall be explicitly followed.
- B. Defective pipe discovered after installation shall be removed and replaced with a sound pipe in a satisfactory manner at no additional cost to VBMU. Thoroughly clean all pipe and fittings before installation and keep installed piping clean until accepted by VBMU.
 - 1. Install PVC pipe and fittings in accordance with the requirements of the manufacturer, ASTM D2321, or as otherwise provided herein.
 - 2. Install ductile iron pipe and fittings in accordance with the requirements of the manufacturer, AWWA C600, or as otherwise provided herein.
- C. Excavate the trench to subgrade and place granular bedding, compacted and graded to provide firm, uniform and continuous support for the pipe. Excavate bell holes so that only the barrel of the pipe bears upon the bedding. Lay the pipe to the lines and grades indicated on the Drawings. Blocking under the pipe will not be permitted. Place granular bedding evenly on each side of the pipe to mid-diameter. Use hand tools to force the bedding under the haunches of the pipe and into the bell holes to give firm continuous support for the pipe. Place granular bedding to 12 inches above the top of the pipe. The initial 3 feet of backfill above the bedding shall be placed in 12-inch layers and carefully compacted. Generally, conduct compaction efforts evenly on each side of the pipe, and do not operate compaction equipment directly over the pipe until sufficient backfill has been placed to prevent damage to the pipe. Equipment used in compacting the initial 3 feet of backfill shall be approved by the pipe manufacturer's representative prior to use.
- D. All piping shall be sound and clean before installation. When installation is not in progress, including breaks and lunchtime, close the open ends of the pipe with a watertight plug or other approved means.
- E. Cut all pipe with a manufacturer-approved cutting machine, leaving a smooth cut at right angles to the axis of the pipe. Bevel the cut ends of pipe to be used with a bell to conform to the manufactured spigot end and make a reference mark at the same distance from the pipe end as measured from a factory marked end from the same manufacturer.
- F. The Engineer may examine each bell and spigot end to determine whether any preformed joint has been damaged prior to installation. Any pipe having defective joint surfaces shall be rejected, marked as such, and immediately removed from the job site.
- G. Each length of the pipe shall have the assembly mark aligned with the pipe previously laid and held securely until enough backfill has been placed to hold the pipe in place.
- H. Before installing a new pipe joint, check the pipe to ensure that a closed joint with the next adjoining pipe has been maintained, and that the inverts are matched and conform to the required grade.

- I. Take all precautions to prevent flotation of the pipe in the trench.
- J. When using moveable trench bracing such as trench boxes, moveable sheeting, shoring or plates to support the sides of the trench, care shall be taken in placing and moving the boxes or supporting bracing to prevent movement of the pipe, or disturbance of the pipe bedding and the backfill. As trench boxes, moveable sheeting, shoring or plates are moved, place additional pipe bedding to fill any voids created, and recompact the backfill to provide uniform side support for the pipe.

3.02 JOINTING SEWER PIPE AND FITTINGS

- A. Install pipe joints in strict accordance with the manufacturer's instructions. Lay pipe with bell ends facing upstream. Insert a rubber gasket in the groove of the bell end of the pipe, and clean and lubricate all joint surfaces. Insert the plain end of the pipe, aligning it with the bell of the pipe to which it is to be joined, and seat it in place by means approved by the pipe manufacturer. Check that the reference mark on the spigot end is flush with the end of the bell.
- B. Make all manhole connections as shown on the Drawings and as specified in Section 420. All manhole connections shall be equipped with an integral O-ring or other sealant, such that a positive watertight seal is established.

3.03 WYE BRANCHES AND MANHOLE STUBS

- A. Furnish, install and cap wye branches as shown on the Drawings or in locations directed by the Engineer. Block each wye branch and end cap with a 2" x 4" wood post that extends to a point 3 feet below the finished ground or by other means as approved by VBMU or the Engineer.
- B. Provide as-built locations for all wyes to the Engineer.
- C. Pipe stubs for manhole connections shall not exceed 4 feet in length unless otherwise directed by the Engineer. Install caps where required.

3.04 SERVICE CONNECTIONS

- A. Install service connections at a minimum slope of 2% at the locations shown on the Drawings and to the limits determined by the Engineer in the field.
- B. Service connections shall be 4-inch diameter unless otherwise shown on the Drawings.

3.05 TESTING

- A. Clean and test all piping in accordance with Section 430. Submit a testing plan including detailed procedures, methods and equipment to be used for pipeline testing at least 10 days before starting the testing for VBMU and the Engineer's review and approval. Furnish all necessary labor and equipment, including gauges, meters, pressure pumps, etc. for carrying out the specified tests. Conduct all tests in the presence of VBMU and the Engineer.

3.06 FINAL CLEANING

- A. At the conclusion of the work, thoroughly clean sewer pipes by flushing with water or other means to remove dirt, stones, pieces of wood, or other material that may have entered during the construction period. Flush the lowest segment outlet last to assure debris removal.

END OF SECTION 410 – SANITARY SEWER LINE IMPROVEMENTS

THIS PAGE LEFT BLANK INTENTIONALLY

SECTION 420 – SANITARY SEWER MANHOLES

PART 1 GENERAL

1.01 SCOPE OF WORK

- A. Furnish all labor, materials, equipment, and incidentals required to install or repair sanitary sewer manholes as shown on the Drawings and as specified herein.
- B. The work shall include monolithically cast-in-place concrete manholes with transitions to lid frames, covers, and accessories.
- C. The work shall also include precast concrete manholes with lid frames, covers and accessories. Precast manholes shall only be allowed in non-pavement areas unless approved by VBMU.
- D. Coordinate all sanitary sewer manhole work with the City of Van Buren Municipal Utilities (VBMU), including field location of existing manholes, installation of new manholes, repair and modification of existing manholes, connection of sewer service lines to existing and proposed manholes, vacuum testing of manholes, and demolition or abandonment of existing manholes.

1.02 RELATED SECTIONS

- A. Section 210 – Trenching and Backfilling
- B. Section 220 – Pavement Repair
- C. Section 230 – Site Restoration
- D. Section 410 – Sanitary Sewer Line Improvements
- E. Section 430 – Testing of Sanitary Sewer Improvements

1.03 REFERENCE STANDARDS

- A. American Society for Testing and Materials (ASTM), latest edition:
 - 1. ASTM A48 Standard Specification for Gray Iron Castings
 - 2. ASTM A536 Standard Specification for Ductile Iron Castings
 - 3. ASTM C33 Standard Specification for Concrete Aggregates
 - 4. ASTM C150 Standard Specification for Portland Cement
 - 5. ASTM C443 Standard Specification for Joints for Concrete Pipe and Manholes, Using Rubber Gaskets
 - 6. ASTM C478 Standard Specification for Precast Reinforced Concrete Manhole Sections

7. ASTM C827 Standard Test Method for Change in Height at Early Ages of Cylindrical Specimens of Cementitious Mixtures
8. ASTM C923 Standard Specification for Resilient Connectors Between Reinforced Concrete Manhole Structures, Pipes, and Laterals
9. ASTM C990 Standard Specification for Joints for Concrete Pipe, Manholes, and Precast Box Sections Using Preformed Flexible Joint Sealants
10. ASTM C1107 Standard Specification for Packaged Dry, Hydraulic-Cement Grout (Nonshrink)

1.04 SUBMITTALS

- A. Submit shop drawings and product data to the Engineer for review.
- B. Provide product data for the following:
 1. Manhole frames and covers with certification indicating conformance with the referenced ASTM standard and class or duty designation,
 2. Pipe connections to cast-in-place structures or precast concrete elements,
 3. Precast concrete base sections, riser sections, conical top sections, and flat slab tops, including certification that indicates conformance with ASTM C478,
 4. Method of repair for minor damage or honeycombing due to casting efforts.
- C. Provide certified design data for the following:
 1. Sectional plans and elevations showing dimensions and reinforcing steel placement,
 2. Structural calculations as requested by the Engineer,
 3. Concrete mix design.
- D. Provide certified test results for the following:
 1. Concrete test testing reports from an approved testing laboratory certifying conformance with the specifications,
 2. Results of field leakage tests.
- E. Manufacturer or fabricator installation instructions.

1.05 QUALITY ASSURANCE

- A. Furnish all new materials and appurtenances.
- B. Furnish product certification indicating compliance with the referenced ASTM standards and these specifications.

- C. Additional inspection criteria shall include appearance; dimensions; the presence of blisters, cracks, or honeycombs; and the general soundness of the structure.
- D. Completed manholes shall be subject to rejection at any time because of failure to meet any of the referenced standards or specification requirements. The Engineer shall mark the rejected manhole or appurtenance, and the Contractor shall demolish and/or remove the item from the project. Rejected items shall be replaced at no additional cost to VBMU.
- E. The Engineer or VBMU may elect to inspect precast concrete manholes at the place of manufacture, at work site delivery, or both. The Contractor shall assist in the scheduling of these inspections as required.

1.06 DELIVERY, STORAGE AND HANDLING

- A. Comply with manufacturer's ordering instructions and lead time requirements to avoid construction delays.
- B. Exercise care in loading, transporting and unloading to prevent damage to precast manhole sections.

1.07 COORDINATION

- A. Verify at the site both the dimensions and work of other trade's adjoining items of work in this Section before commencement of items specified herein.
- B. Do not disrupt service to utility customers during installation of the sanitary sewer improvements except for the time required to make connections to a new sewer.
- C. Notify VBMU and the Engineer at least 48 hours prior to scheduling connections to existing manholes. Scheduling shall be subject to the approval of VBMU and the Engineer.

1.08 FIELD MEASUREMENTS

- A. Take field measurements at the site to verify or supplement indicated dimensions and to ensure proper coordination of all other construction items.

PART 2 PRODUCTS

2.01 GENERAL

- A. Reference to a manufacturer's name and model or catalog number is for the purpose of establishing the standard of quality and general configuration desired.
- B. Like items of materials, equipment or appurtenances shall be the products of one (1) manufacturer in order to provide standardization for appearance, operation, maintenance, spare parts and manufacturer's service.
- C. Cement shall conform to ASTM C150, Type II cement or equal.
- D. Provide lifting lugs or holes in each precast manhole section for proper handling.

- E. Mark date of manufacture, name, and trademark of manufacturer on the inside of each precast section.

2.02 CONCRETE FOR MANHOLES

- A. Unless otherwise noted on the Drawings, cast-in-place concrete for manholes shall have a minimum 28-day compressive strength of 3,500 psi, with 4.0 to 7.0% air entrainment.
- B. Unless otherwise noted on the Drawings, concrete precast manholes shall have a minimum 28-day compressive strength of 4,000 psi and conform to ASTM C478. Precast concrete sections shall be properly cured prior to shipping.

2.03 PRECAST CONCRETE MANHOLE SECTIONS

- A. Precast concrete base sections, riser sections, conical top sections, flat slab tops, and grade rings shall conform to ASTM C478 and shall meet the following requirements:
 - 1. Design precast concrete base and flat slab top for their own weight, weight of soil at 130 pounds-per-cubic feet (pcf), and a live load equal to AASHTO H-20 truck loading (for pavement sections) or 300 pounds-per-square-foot (psf) loading (for non-pavements sections) applied at finished grade.
 - 2. Construct precast concrete bases as shown on the Drawings and as described in this Section.
 - 3. Base, riser and transition top sections shall have tongue and groove joints.
 - 4. Unless otherwise indicated on the Drawings, top sections shall be concentric cones where pipe cover exceeds 4 feet. Top section shall be a flat slab where cover over top of pipe is 4 feet or less.

2.04 MORTAR

- A. Mortar shall consist of one (1) part Type II Portland cement and two (2) parts clean sand with only enough water for workability.

2.05 GROUT

- A. Unless otherwise noted, utilize a non-shrink cementitious grout for manholes that meets or exceeds the requirements of ASTM C1107 Grades B or C. Grouts shall be Portland cement-based, contain a pre-proportioned blend of select aggregates and shrinkage compensating agents, and shall require only the addition of water. Non-shrink cementitious grouts shall not contain expansive cement or metallic particles. The grouts shall exhibit no shrinkage when tested in conformity with ASTM C827:
 - 1. General purpose non-shrink cementitious grout shall conform to the standards stated above and shall be SikaGrout 212 by Sika Corp.; Set Grout by Master Builders, Inc.; Gilco Construction Grout by Gifford Hill & Co.; Euco NS by The Euclid Chemical Co.; NBEC Grout by U. S. Grout Corp.; or equal.

2.06 JOINT SEALING MATERIAL

- A. Precast Joints: Seal tongue and groove joints of precast concrete manhole sections with a prelubricated rubber O-ring gasket. O-ring gaskets shall conform to ASTM C443; and shall be Tylox Superseal by Hamilton Kent, Reduced Friction Seal (RFS) by Press-Seal Gasket, or approved equal.
- B. Exterior Structure Joints – Sealing material for sealing exterior joints in precast manhole sections, concrete adjusting collars, cast iron adjusting rings, and cast iron frames shall be Wrapidseal manufactured by Canusa, Infi-Shield manufactured by Sealing Systems, Inc., or approved equal.
- C. Completed joints shall meet the vacuum test requirements detailed at the end of this Section.

2.07 FLEXIBLE GASKETS FOR WALL PENETRATIONS

- A. Elastomeric Waterstop Gaskets: Waterstop gaskets for pipe entrances into cast-in-place concrete manholes shall be made of elastomeric PVC and shall be Fernco Concrete Manhole Adapters (CMA's) for pipe diameters 12 inches and smaller, Fernco Large-Diameter Waterstops for pipe diameters larger than 12 inches, or approved equals.
- B. Flexible Waterstop Pipe Connections: Waterstop gaskets for pipe entrances into precast concrete manholes shall be flexible watertight connectors, made of natural or synthetic rubber, conforming to ASTM C923, and shall be A-LOK Premium as manufactured by A-LOK Products, Inc., or approved equal.

2.08 CONCRETE ADJUSTMENT COLLARS

- A. Concrete adjusting collars, used for setting the cast iron frame and covers to the required elevation, shall be made of concrete, shall have a minimum wall thickness of 6 inches, and shall have an inside diameter the same as the existing inside diameter of the top of the manhole.

2.09 MANHOLE FRAMES AND COVERS

- A. Standard Frame and Cover: Circular manhole ring and cover, cast iron, with a heavy duty load rating. Manhole covers shall have a 22-inch diameter (minimum) clear opening; have a frame height of 5-3/4 inches (minimum); and include a notch or tool entrance to permit removal of the cover, but no other "pick holes", vents or other such opening for the entrance of surface water drainage. Frame and cover shall have machined bearing surfaces to prevent rocking of the cover. Castings shall be free from cracks, holes and swells. Frames and covers shall be Class 35B gray iron conforming to ASTM A48.
 - 1. Standard manhole frames and covers (22-inch opening) shall be East Jordon Iron Works (EJ) Catalog No. 1348A/1348Z.
 - 2. Large manhole frames and covers (30-inch opening) shall be East Jordon Iron Works (EJ) Catalog No. 1322A/1322Z.
- B. Bolt-down Frame and Cover: Circular manhole ring and cover, cast iron, with a heavy duty load rating. Manhole covers shall have a 24-inch diameter (minimum) clear opening; have a frame height of 6 inches (minimum); include gasketed and threaded frame holes to receive a minimum of three (3) cam-style, machined stainless steel bolts to hold the cover in place; and include a notch or tool entrance to permit removal of the cover. Cover shall include no other "pick holes",

vents or other such opening for the entrance of surface water drainage. Castings shall be free from cracks, holes and swells. Frames shall be Class 35B gray iron conforming to ASTM A48. Covers shall be Class 35B gray iron conforming to ASTM A48 or Grade 70-50-05 ductile iron conforming to ASTM A536.

1. Bolt-down manhole frames and covers within 2 feet of finished grade shall be East Jordon Iron Works (EJ) *Camprission Watertite Assembly* (cam-lock style), Product No. 42339048W01, or approved equal. Covers shall include "Sanitary Sewer" lettering.
2. Bolt-down manhole frames and covers that are more than 2 feet above finished grade shall be East Jordon Iron Works (EJ) *Revolution Access Assembly* (pivoting lid style), Product No. 00104175R01, or approved equal. Covers shall include "Sanitary Sewer" lettering

2.10 FLEXIBLE GASKETS FOR MANHOLE FRAMES

- A. Flexible gaskets for connecting cast iron frames and concrete adjustment rings to the tops of manholes shall conform to ASTM C990 and be one (1) of the following:
 1. Preformed flexible plastic gaskets similar and equal to Ram-Nek by Henry Company.
 2. Butyl rubber gaskets similar and equal to Rubr-Nek LTM by Henry Company.

2.11 MANHOLE ADJUSTMENT RINGS

- A. Manhole adjusting rings shall be cast iron conforming to ASTM A48 or ductile iron conforming to ASTM A536. Adjusting rings shall be similar and equal to the R-1979 series manufactured by Neenah Foundry. The Contractor shall determine all dimensions and shall ensure correct sizing of the adjusting rings.

2.12 MANHOLE PATCHING MATERIAL

- A. Manhole Patching Material for filling voids and repairing walls and inverts of concrete, brick, or other masonry structures shall be a rapid-setting (10-15 minutes), fiber-reinforced, high-early strength, corrosion-resistant, hand mixed, hand-applied, calcium aluminate-based cementitious material conforming to Strong-Seal QSR as manufactured by Strong Company or approved equal. The patching material shall have a minimum compressive strength of 1,400 psi at 6 hours and shall be factory blended requiring only the addition of water at the jobsite.

2.13 MANHOLE LEAK-STOP MATERIAL

- A. Manhole Leak-Stop Material shall be used where the infiltration flow rate through the manhole wall or pipe connection is greater than can be controlled with manhole patching material. Manhole Leak-Stop Material shall be specifically formulated for leak control, rapid-setting (60 seconds), fiber-reinforced, high-early strength, corrosion-resistant, hand-mixed, hand-applied, calcium aluminate-based cementitious material conforming to Strong-Plug as manufactured by Strong Company or approved equal. The leak stop material shall have a minimum compressive strength of 1,000 psi at 24 hours and shall be factory blended requiring only the addition of water at the jobsite.

PART 3 EXECUTION

3.01 GENERAL REQUIREMENTS FOR MANHOLES

- A. Construct manholes to the dimensions shown on the Drawings and as specified herein. Unless otherwise noted in Part 1 above, manholes shall be constructed of cast-in-place concrete.
- B. Manholes constructed of fiberglass or other materials will not be allowed.
- C. Finished manhole shall have an inside diameter of 48 inches (minimum) from the base to the sloping cone section at the top of the manhole, unless otherwise noted on the Drawings. Install larger diameter manholes (minimum diameter of 5 feet) for sections deeper than 12 feet and for sewer pipe diameters larger than 24 inches to provide sufficient access and for the forming of manhole flow inverts. The inside diameter of the opening at the top of the cone section shall not be less than 26 inches. Unless otherwise noted on the Drawings, the sloping cone section shall be concentric and have a height of not less than 24 inches and not more than 36 inches.
- D. Manholes installed on existing sewer lines shall be constructed in a manner that will not disturb the alignment and grade of the existing pipe except for required alterations. Existing pipes within the manhole shall be removed as required to permit construction of the manhole invert. When authorized by the Engineer, the manhole may be constructed with the sewer pipe in place and the upper half of the pipe removed after the invert has been constructed.
- E. Do not install steps, rungs or ladders unless specifically indicated on the Drawings.
- F. Protect all work against flooding and flotation.

3.02 MANHOLE BASES

- A. The bottom of the concrete manhole base shall be level, and the minimum thickness of the concrete base below the invert of the channel shall be 12 inches.
- B. Regardless of the type of manhole construction, construct channels at the bottom of each manhole. The invert channels shall be smooth, shall be accurately shaped to a semi-circular bottom conforming to the inside shape of the adjacent sewer section, shall have a uniform slope from the inlet to the outlet pipe, shall extend up to at least half of the diameter of the pipe, and shall have smooth curves with radii as large as the size of the manhole will permit. Unless indicated on the Drawings, maintain a minimum 0.1 foot drop from the inlet invert to the outlet invert of each manhole.
- C. All manholes shall contain a concrete shelf on each side of the invert channel. The top of the shelf at the edge of the channel shall be a minimum of one-half (50%) of the largest diameter of the connecting pipe above the invert of the channel. The shelf shall rise a minimum of 1-inch per foot from the edge of the channel to the wall of the manhole. Dips or projections capable of holding water or solid materials will not be permitted.
- D. Cast-In-Place Manhole Bases
 - 1. The concrete foundation for cast-in-place manholes shall be placed as soon as practicable after the sewer pipe has been installed through the manhole location. The concrete for the base of the manhole shall be placed on a 6-inch thick (minimum) layer of crushed stone conforming to ASTM C33. Form invert channels in the concrete base during or immediately

after the placing of the manhole base and provide a brush finish as soon as the concrete has sufficiently set. Where required to correct deficiencies in the constructed concrete invert, invert channels shall be shaped and smoothed with manhole patching material.

2. In manholes where there is only one (1) inlet and one (1) outlet pipe and the sewer pipe does not change direction, the invert through the manhole shall be of split pipe or the pipe may be laid through the manhole and the upper half of the pipe removed. The pipe shall be cut in a neat and workmanlike manner prior to removing the top section of the pipe. The concrete shall set for 24 hours before any pipe inside the manhole is trimmed.

E. Precast Manhole Bases

1. Where precast manholes are used that include a bottom section containing the invert, the flow channel and shelf shall be formed during the casting process of the precast manholes. Install flexible waterstop pipe connectors at locations where sewer main pipe and sewer service pipe enter the manhole.
2. The bottom of the base section shall be level and shall be placed on a 6-inch thick (minimum) layer of crushed stone conforming to ASTM C33. Set grade stakes consisting of four #4 re-bars at the bottom of the excavation, spaced at approximately 90°, and with the tops set to the finished gravel grade.
3. Where the manhole base is not cast as part of the precast manhole assembly, construct the base as previously detailed for cast-in-place manholes and extend it a minimum of 4 inches beyond the edge of the precast manhole walls. Embed a minimum of 3 inches of the bottom precast section in the cast-in-place base and place the precast section either prior to placing concrete for the base or prior to the initial set of the concrete.

3.03 MANHOLE WALLS

A. Cast-in-Place Manhole Walls

1. Set manhole form sections plumb and level, trim to correct elevations, and anchor to the base pad. Cast-in-place manholes shall have minimum wall thickness as shown in Table 420.1.

Manhole Depth	Minimum Thickness of Wall
up to 12 feet	6 inches
over 12 feet	8 inches

2. The wall shall be poured monolithically with the base, or the base shall be provided with a construction joint and waterstop. The forms used for construction of the barrel shall be of such fabrication and set so that the walls of the manhole constructed are to the minimum thickness noted above and shall be smooth with no form marks on the interior or exterior wall exceeding 1/4 inch.
3. The concrete shall be placed uniformly around the manhole in maximum lifts of 2 feet. Each lift shall be thoroughly vibrated prior to placement of succeeding lifts. All concrete shall be free of honeycomb or other defects. The Contractor shall correct all defective areas as directed by the Engineer or VBMU.

B. Precast Manholes

1. Prior to ordering any precast manhole units, the Contractor shall verify the location and depth of all existing and proposed pipe connections to the manhole. The Contractor shall also verify that existing sewer services, connected to an existing manhole to be replaced, are active.
2. Precast manhole sections shall have a minimum wall thickness of 5 inches or as specified by the manufacturer to conform to the requirements of ASTM C478. Any precast section that has been damaged such that the water tightness of the section or joint is affected shall not be utilized.
3. Pre-formed neoprene O-ring gaskets shall be used in the joint between precast manhole wall sections. The exterior of the joint shall be grouted as necessary to form a smooth and uniform surface.
4. Exterior joint sealing material conforming to the requirements of ASTM C990 and having a minimum width of 12 inches, shall be wrapped around the outside of the manhole and centered over the joint. The installation of the joint sealing material shall conform to the manufacturer's written recommendations.
5. Allow joints to set for twenty four (24) hours before backfilling unless a shorter period is specifically approved by the Engineer.
6. Plug holes in the concrete sections required for handling with non-shrink grout or non-shrink grout in combination with concrete plugs. Finish flush on the inside.
7. Cut holes in precast sections to accommodate pipes prior to setting precast sections in place to prevent jarring that may loosen the grouted areas.

3.04 MANHOLE FRAMES AND COVERS

- A. Install cast iron frame and covers on the top of all manholes. Center the cast iron frames over the manhole cone section, carefully leveled and placed to the elevations shown on the Drawings or to an elevation as directed by the Engineer. Install concrete adjusting collars and mortar as required to set the top of the frame at the correct elevation and slope. Unless otherwise directed by the Engineer, the top of the frame and cover shall conform to the following requirements:
1. Within or adjacent to paved street or driving surfaces: Set the top at the same elevation and slope as the adjacent paved surface. Utilize a grade adjusting ring when sloping of the frame and cover is required.
 2. Within maintained lawn areas: Set the top level with the adjacent ground.
 3. Within pastureland or open areas, except near drainage channels or ditches: Set the top a minimum of 6 inches above the adjacent ground.
 4. Near drainage channels or ditches: Set the top a minimum of 12 inches above the adjacent ground or as indicated on the Drawings.

5. Within asphalt paved areas: Set manhole frame and cover to final grade prior to construction of permanent pavement. Construct a 6-foot square, 6-inch minimum thick concrete cap around the manhole frame and cover unless otherwise indicated on the Drawings.
- B. Cone Top Section: Attach the cast iron frame and concrete adjusting collars to the top of the manhole cone section using a flexible plastic or butyl rubber gasket. Construct a concrete grout cap around the cast iron frame and any concrete adjusting rings. Grout the manhole wall as necessary to form a continuous smooth and uniform surface from 3 inches below the top of the cone to 1 inch above the bottom of the cast iron frame. After the grout has cured, wrap exterior joint sealing material, having a minimum width of 12 inches, around the outside of the manhole and centered over the joints between the cast iron frame, concrete adjusting rings, and manhole wall. The installation of the joint sealing material shall conform to the manufacturer's written recommendations.
- C. Flat slab top section: If flat slab top precast sections are approved, set top section (with integral frame and cover) level and without tipping, to correct elevations. Utilize precast concrete grade rings, a maximum of 8 inches thick, to assure the frame and cover are set to finished grade.
- D. Backfill and compaction shall be as specified in Section 210, Trenching and Backfilling.

3.05 PIPING CONNECTIONS TO MANHOLES

- A. New Cast-in-Place Manholes: Install an elastomeric waterstop gasket around each pipe extending through the manhole wall and center each gasket in the wall to insure a watertight connection. Set pipe with installed gasket in place prior to placing concrete for the manhole base.
- B. New Precast Manholes: Install flexible waterstop pipe connectors during the manufacture of the precast manhole. Insert the pipe through the connector to the depth recommended by the manhole manufacturer. After the pipes have been installed, grout the invert channel to the spring line of the pipe to provide smooth flow through the manhole. Do not apply grout at the pipe connection on the outside of the manhole unless directed by the waterstop manufacturer.
- C. Pipe Connections to Existing Manholes:
 1. At locations where a new sewer pipe is to join an existing manhole, the work shall consist of making an opening in the manhole wall, inserting the new pipe and an elastomeric waterstop gasket to the elevation shown on the Drawings, constructing necessary drop connections, and reconstructing the manhole invert.
 2. Core openings in the manhole for the pipe (the use of hammers not permitted). Install an elastomeric waterstop gasket in the cored opening between the manhole and pipe and repair the hole in the concrete wall with manhole patching material. The patching material shall extend a minimum of 1 inch beyond the inside and outside surface of the wall and a minimum of 3 inches beyond the edge of the hole. The patch material shall cure for a minimum of one hour prior to wastewater flowing across it.
 3. If the connecting pipe requires modification to the existing invert channel, the existing channel shall be removed to the extent necessary for a new invert channel to be constructed to provide a smooth flow through the manhole.
 4. If approved by VBMU, the Contractor may temporarily block and/or divert sewage flows to facilitate construction operations. Otherwise, the Contractor shall provide bypass pumping

around the manhole in question. No bypassing of sewage flows to ditches, streams, storm sewers, or the ground will be permitted.

- D. Pipe Stub-Outs: Where shown on the Drawings or as directed by the Engineer, install pipe stub-outs in manholes for future extension or for service connections. Construct pipe stub-outs as specified above for pipe connections. Close or seal pipe stubs for future connections with a gasketed watertight plug or standard glued fitting. Unless otherwise noted, the stub-out pipe shall extend a minimum of 3 feet from the edge of the manhole.

3.06 MANHOLE DROPS

- A. Construct manhole drops at locations where the invert of the inlet sewer main pipe enters a manhole at a greater depth than 2 feet above the invert of the outlet pipe. The pipe and fittings for the drops shall be of the same material, type, and size as the horizontal inlet pipe. The drops shall be constructed to the dimensions and in accordance with the details shown on the Drawings. The horizontal sewer pipe shall extend through the manhole wall. Concrete shall be used to backfill around the vertical pipe drops and fittings from the bottom of the excavation to 6 inches above the top of the horizontal inlet pipe. Extend concrete encasement to the undisturbed earth at the trench line of the incoming sewer pipe. Interior manhole drops are not permitted.

3.07 REPAIR AND RECONSTRUCTION OF EXISTING MANHOLES

- A. Preparation for Repairs:

- 1. Prior to performing any work or repairs on the existing manhole, plug the pipes entering the manhole to prevent foreign material from entering the manhole or sewer pipe slated for repair. Pump incoming sewage around the manhole to a downstream manhole. Bypassing of sewage flows to ditches, streams, storm sewers, or the ground will not be permitted.
- 2. Remove foreign material from the manhole invert using a minimum 1,500-psi water spray. Pump out or otherwise remove cleaning water from the manhole and dispose in a downstream manhole as necessary.

- B. Invert Channel Repairs

- 1. Where shown on the Drawings or as directed by the Engineer, repair broken or damaged manhole inverts using manhole patching material. Remove loose and protruding brick, mortar, and concrete using a mason's hammer and chisel, scraper, or other equipment approved by the Engineer. Fill or repair all holes, cracks, and other defective areas in the manhole invert using hand-applied manhole patching material.
- 2. Uniformly trowel a coating of manhole patching material onto the entire invert to a minimum thickness of 1/2 inch in an expeditious manner. Extra care shall be taken to insure complete filling of the void at the pipe connection with manhole patching material. Extend the coating out onto the invert bench to the walls of the manhole or, if shown on the Drawings, a sufficient distance to tie into the manhole grout liner, which will be spray-applied following the invert repair work. The finished coated surfaces shall be smooth and free of ridges. Mix, handle, and apply of the patching material in accordance with the manufacturer's written recommendations. Allow the patching material to cure for a minimum of 30 minutes prior to allowing wastewater to flow across it.

C. Repairs to Existing Pipe Connections:

1. Where shown on the Drawings or as directed by the Engineer, repair existing pipe connections. Remove the concrete, brick, or mortar around the pipe connection to the manhole to a minimum distance of 3 inches beyond the outside edge of the pipe and to minimum depth of 5 inches from the inside edge of the manhole wall. Install an elastomeric waterstop gasket around the sewer pipe and repair the hole and damaged manhole invert with manhole patching material.

3.08 MANHOLE GRADE ADJUSTMENT

- A. Adjust existing manholes to grade using grade adjustment rings; by removal and replacement of the frame and cover; or by reconstruction, modification or replacement of the top portion of the structure as shown on the Drawings or as directed by the Engineer. Any portion of the remaining manhole structure damaged due to the negligence of the Contractor shall be repaired by the Contractor without compensation. The top of the frame and cover shall conform to the general requirements as previously described in this Section.
- B. Backfill and compaction shall be as specified in Section 210, Trenching and Backfilling.
- C. At locations where the existing manhole is buried, VBMU will assist the Contractor in locating the manhole.
- D. Raising top less than 4 inches: Where the top of the manhole is to be raised less than 4 inches, install a cast iron grade adjustment ring(s) in the existing frame. The rings shall be firmly seated in the existing manhole frames and shall be non-rocking. Adjust manholes in pavement areas prior to the start of the pavement overlay operations to the proposed finish grade.
- E. Raising top between 4 and 24 inches: Where the top of the manhole is to be raised between 4 and 24 inches, remove the existing frame and cover. Using concrete adjusting collars and mortar as required, set the top of the frame to the correct elevation and slope. Reinstall the existing frame and cover as described previously in this Section, including the installation of flexible plastic gaskets and joint sealing material. Where directed by the Engineer, install a new cast iron frame and cover and deliver the existing frame and cover to VBMU.
- F. Raising top over 24 inches: Material requirements and installation details for raising manhole tops over 24 inches shall be preapproved by VBMU. Where the top of the manhole is to be raised over 24 inches, insert a new manhole wall section onto the existing manhole below the cone section. Remove and salvage the existing cast iron frame and remove and dispose of the cone shaped portion of the manhole. Clean and grind the top of the remaining manhole to a smooth uniform surface. Patch and repair the edge using mortar as required.
 1. Install a new precast reinforced concrete cylindrical manhole wall section, having an inside diameter the same as the existing inside diameter of the manhole and having a minimum wall thickness of 5 inches. Install the new section on top of the remaining portion of the existing manhole barrel using a flexible plastic gasket.
 2. Install a new precast concrete manhole cone section having a minimum wall thickness of 5 inches on the new cylindrical section using pre-formed neoprene O-ring gasket.
 3. Reinstall the existing frame and cover using concrete adjusting collars and mortar as required to set the top of the frame at the correct elevation and slope. Where directed by the Engineer,

install a new cast iron frame and cover and deliver the existing frame and cover to VBMU. The installation of the frame and cover shall be as previously described in this Section, including the installation of flexible plastic gaskets and joint sealing material at the joints in the newly constructed wall and cone sections.

- G. Lowering Top: Material requirements and installation details for lowering manhole tops shall be preapproved by VBMU. Where the top of the manhole is to be lowered, remove the existing frame and cover. Depending on the elevation and condition of the existing manhole cone section and the depth to which the manhole needs to be lowered, remove the existing manhole cone and portions of the wall as necessary to achieve the required elevation as directed by the Engineer. The installation of the new manhole wall and cone sections and the installation of the frame and cover the grade shall be as previously described in this Section.
- H. Where a manhole structure interferes with the construction of a sidewalk, the grade of the manhole cover must be flush with the finished surface of the concrete sidewalk, and the adjustment (raising or lowering) of any manhole must be preapproved by VBMU. If the grade of the sidewalk or the grade of the manhole cover cannot be satisfactorily adjusted, the sidewalk must be installed around the manhole.

3.09 REMOVING AND ABANDONING MANHOLES

- A. Prior to the removal or abandonment of an existing manhole, remove the frames and covers and deliver them to VBMU. Plug all pipes entering the manhole with concrete for a minimum distance of 12 inches from the inside wall of the manhole.
- B. Remove designated manholes in their entirety including foundation or base unless otherwise noted on the Drawings or as directed by the Engineer. Dispose of all materials off-site and backfill the hole with compacted borrow.
- C. For manholes designated to be abandoned, remove the top portion of the manhole to a depth of 3 feet below the adjacent surface and disposed of off-site. Plug all pipe penetrations with low slump, non-shrink concrete or grout, and fill the remaining portion of the manhole with flooded sand consolidated by means of vibratory equipment. Use on-site material to complete the backfilling. Flowable Fill or other special backfill material shall be used where noted on the Drawings or as directed by the Engineer.

3.10 ABANDONING PIPE CONNECTIONS TO EXISTING MANHOLES

- A. At locations where an existing pipe is to be abandoned at an existing manhole, plug the end of the pipe at the manhole by packing the pipe with a low slump, non-shrink concrete or grout for a minimum distance of 12 inches from the inside wall of the manhole.
- B. Reshape the invert with manhole patching material to form a new smooth channel flow through the manhole and a new bench as required. Prior to performing any work on the manhole invert, plug the remaining pipes entering the manhole to prevent foreign material from entering the manhole. Remove all foreign material from the manhole invert using a minimum 1,500-psi water spray. The minimum thickness of the patching material shall be 1/2 inch, and the finished surfaces shall be smooth and free of ridges. Mix, handle, and apply the patching material in accordance with the manufacturer's written recommendations. Allow the patching material to cure for a minimum of 30 minutes prior to allowing wastewater to flow across it.

- C. While plugging pipes and repairing manhole inverts, provide temporary bypassing pumping of the sewage around the manhole to another downstream manhole.

3.11 MANHOLE TESTING

- A. Clean and test all new manholes in accordance with Section 430. Test existing manholes that have been repaired or relined as indicated on the Drawings or as directed by the Engineer. Submit a testing plan including detailed procedures, methods and equipment to be used for manhole testing at least 10 days before starting the testing for Engineer's review and approval. Furnish all necessary labor and equipment, including gauges, meters, vacuum pumps, etc. for carrying out the specified tests. Conduct all tests in the presence of the Engineer.

3.12 FINAL CLEANING

- A. At the conclusion of the work, thoroughly clean sewer manholes by flushing with water or other means to remove dirt, stones, pieces of woods, or other material that may have entered during the construction period. Remove debris and do not allow it to be flushed into downstream sections of the collection system.

END OF SECTION 420 – SANITARY SEWER MANHOLES

SECTION 430 – TESTING OF SANITARY SEWER IMPROVEMENTS

PART 1 GENERAL

1.01 SCOPE OF WORK

- A. Furnish all labor, materials, equipment and related items required to perform inspection and testing of sanitary sewer piping and manholes.
- B. Coordinate all inspection and testing of sanitary sewer lines and manholes with the City of Van Buren Municipal Utilities (VBMU), including pressure and deflection testing of gravity sewer lines, pressure testing of force mains, vacuum testing of existing and proposed manholes, and conducting closed-circuit television (CCTV) inspections of sewer lines.

1.02 RELATED SECTIONS

- A. Section 330 – Testing of Water Line Improvements
- B. Section 410 – Sanitary Sewer Line Improvements
- C. Section 420 – Sanitary Sewer Manholes

1.03 REFERENCE STANDARDS

- A. American Society for Testing and Materials (ASTM), latest edition:
 - 1. ASTM C1244 Standard Test Method for Concrete Sewer Manholes by the Negative Air Pressure (Vacuum) Test Prior to Backfill
 - 2. ASTM F1417 Standard Practice for Installation Acceptance of Plastic Non-pressure Sewer Lines Using Low-Pressure Air

1.04 SUBMITTALS

- A. Submit copies of all field leakage test reports and electronic copies of all CCTV videos.

PART 2 PRODUCTS

2.01 WATER FOR TESTING

- A. Notify VBMU 24 hours prior to scheduling sewer line testing. The Contractor is responsible for obtaining suitable water from an approved source for exfiltration testing of gravity sewer lines. In certain cases, VBMU may elect to provide water for exfiltration testing and will install a hydrant meter at a nearby fire hydrant. The Contractor is responsible for all additional hoses, valves and other connection appurtenances. The Contractor shall also provide an approved air gap or other means of preventing backflow of contaminated water into the potable water system. Excessive or wasteful usage of water shall not be tolerated. Water valves on the existing water distribution system may only be operated by VBMU personnel.

PART 3 EXECUTION

3.01 GENERAL

- A. Field-test the entire length of installed gravity sewer lines for alignment and water tightness.
- B. Furnish all labor and equipment, including a pressure pump for conducting pipeline tests, a vacuum pump for manhole tests, meters, and gauges.
- C. Perform a final CCTV inspection following the installation of new sewer lines or the rehabilitation of existing sewer lines to document all work performed. Copies of CCTV videos shall be submitted to VBMU on a flash drive or portable hard drive. The cost of performing the final CCTV inspection shall be considered incidental to the cost of constructing the sanitary sewer improvements, and final payment for work will not be considered until post-construction CCTV videos are received, reviewed and accepted by VBMU. Similarly, sanitary sewer improvements by a Developer's Contractor will not be accepted into the Van Buren sewer collection system until post-construction CCTV videos of all construction have been received, reviewed and accepted by VBMU.
- D. Schedule time and sequence of testing, subject to observation and approval by VBMU and the Engineer. Locate and repair any leaks or alignment issues discovered the course of the tests at no additional cost to VBMU.

3.02 CLEANING

- A. At the conclusion of the work and prior to testing, thoroughly clean all sewers and manholes by flushing with water or other means to remove all dirt, stones, pieces of wood, or other material that may have entered the pipes during the construction period. Remove debris cleaned from the lines from the low end of the sewer. Remove all temporary pipeline plugs or other obstructions after cleaning and/or testing.

3.03 TEST PROCEDURES FOR GRAVITY SEWER LINES

- A. Gravity Sewer Lines, General: Install and backfill gravity sewers, and then test pipe using either Exfiltration Water Testing or Low Pressure Air Testing. Test all gravity pipelines using the Allowable Deflection Test.
- B. Exfiltration Water Testing of Gravity Sewers
 1. Fill the section of pipe with water and allow it to stand for a sufficient time to adsorb such water as it will and for the escape of all air from the line. Carefully examine the sections undergoing testing for leakage. Repair all known leaks, regardless of these test requirements.
 2. Fill the pipeline to a reference level in a manhole or reservoir of sufficient capacity to allow a reference level to be established. The reservoir must be of sufficient capacity to prevent the water level from dropping below the crown of the pipe during the 24-hour test period. If the water level drops below the crown of the pipe, the test shall be voided and run again until such time that the water level is maintained above the crown throughout the duration of the test.
 3. At the end of a 24-hour period, add water as necessary to the pipeline to bring the water level back to the referenced line. Accurately measure all added water with an approved water meter to establish an exfiltration rate.

4. Leakage during the above test shall not exceed a rate equal to 50 gallons per inch of internal diameter per mile per 24 hours.
5. Repair all observed leaks regardless of the measured leakage rate.
6. Exfiltration testing results are not acceptable under circumstances wherein the groundwater elevation is above the pipe being tested. Groundwater monitoring test procedures shall be used to confirm the groundwater level for exfiltration testing.

C. Low Pressure Air Testing of Gravity Sewers

1. Perform this low pressure air testing in accordance with ASTM F1417 or other appropriate procedures. For safety reasons, limit air testing to pipe sections 24-inch diameter and smaller (average inside diameter). Lines larger than 24-inch diameter may be air tested at each joint.
2. For sections of pipe 24-inch diameter and smaller, compute the minimum time allowed for the pressure to drop from 3.5 psi to 2.5 psi by the following equation:

$$T = \frac{0.085 * D * K}{Q}$$

Where: T = time for pressure to drop 1.0 psi gauge, in seconds
K = 0.000419 * D * L, but not less than 1.0
D = average inside diameter, in inches
L = length of line of same pipe size being tested, in feet
Q = rate of loss, assume 0.0015 ft³/minute/square feet internal surface

3. Repair all observed leaks regardless of the air test results.

D. Allowable Deflection Test

1. Conduct pipe deflection testing on all gravity pipes constructed of flexible materials.
2. Pipe deflection measured not less than ninety (90) days after the backfill has been completed as specified shall not exceed five percent (5%). Compute pipeline deflection by multiplying the amount of deflection (nominal diameter less minimum diameter when measured) by 100 and dividing by the nominal diameter of the pipe.
3. Measure deflection with a rigid mandrel (Go/No-Go) device, cylindrical in shape and constructed with a minimum of nine or ten (9 or 10) evenly shaped arms or prongs. Submit drawings of the mandrel with complete dimensions to the Engineer for each diameter of pipe to be tested. Manually pull the mandrel through all sewer lines.
4. Uncover any section of sewer not passing the mandrel, and replace bedding and backfill to prevent excessive deflection, at no additional cost to VBMU. Retest all repaired pipe.
5. Provide a mandrel approved by the manufacturer of epoxy lined sewer pipes, particularly those lined with Protecto 401 liner. In general, sizing mandrels for epoxy lined pipes shall be plastic balls with grooves to allow the passage of debris, or metallic mandrels with polyethylene or other plastic skid plates at pipe contact points.

3.04 TEST PROCEDURES FOR PRESSURE PIPELINES

- A. Test pressurized sewer pipelines (force mains) in accordance with Section 330, Testing of Water Line Improvements.

3.05 FIELD TESTING OF NEW MANHOLES

- A. Vacuum test each new manhole prior to acceptance. Test manholes after piping connections have been made and prior to backfilling. Provide all vacuum pumps, gauges, testing equipment and plugs necessary for the testing of manholes. The Engineer's representative must be present for all testing to be approved. Repair any manholes that do not pass and retest.
- B. Conduct tests in accordance with ASTM C1244 after all pipe connections have been made, and prior to backfilling the manhole. Temporarily plug all pipe penetrations using suitably sized pneumatic or mechanical plugs.
- C. Place a metal cover with suitable gasket over the top of the manhole frame. The metal cover shall be provided with valved pipe connections for attaching the vacuum pipe and a vacuum gauge reading inches of mercury or psi. Apply a reduced pressure condition equal to 10 inches of mercury (5 psi). The manhole shall be considered as exhibiting adequate exfiltration if the pressure does not drop the equivalent of 1 inch of mercury within the time limitations shown in Table 430.1.

**Table 430.1
Manhole Vacuum Test Duration**

MH Depth	48-inch Diameter	60-inch Diameter	72-inch Diameter	96-inch Diameter	120-inch Diameter
4-ft.	10 seconds	13 seconds	16 seconds	23 seconds	29 seconds
6-ft.	15 seconds	20 seconds	24 seconds	34 seconds	43 seconds
8-ft.	20 seconds	26 seconds	33 seconds	45 seconds	57 seconds
10-ft.	25 seconds	33 seconds	41 seconds	56 seconds	71 seconds
12-ft.	30 seconds	39 seconds	49 seconds	67 seconds	85 seconds
14-ft.	35 seconds	45 seconds	57 seconds	78 seconds	100 seconds
16-ft.	40 seconds	52 seconds	67 seconds	89 seconds	114 seconds
18-ft.	45 seconds	59 seconds	73 seconds	100 seconds	128 seconds
20-ft.	50 seconds	65 seconds	81 seconds	111 seconds	142 seconds
22-ft.	55 seconds	72 seconds	89 seconds	122 seconds	156 seconds
24-ft.	59 seconds	78 seconds	97 seconds	133 seconds	170 seconds
26-ft.	64 seconds	85 seconds	105 seconds	144 seconds	185 seconds
28-ft.	69 seconds	91 seconds	113 seconds	155 seconds	199 seconds
30-ft.	74 seconds	98 seconds	121 seconds	166 seconds	213 seconds

Greater than 30-ft. deep or 120-inch diameter – to be confirmed by the Engineer.

3.06 FIELD TESTING OF EXISTING MANHOLES

- A. Grout Lined Manholes: At the direction of the Engineer, visually verify the absence of leaks in the manhole walls and base and perform an exfiltration test as follows:

1. Manholes 0 to 6 feet deep: If water loss is 1 inch or less in 5 minutes, the manhole is considered acceptable.
2. Manholes over 6 feet deep: If water loss is 1 inch or less (plus 1/8 inch per additional foot of manhole depth) in five minutes, the manhole is considered acceptable.

3.07 FINAL ACCEPTANCE

- A. VBMU will not accept completed sewer lines or manholes until the Contractor has repaired all visible leaks, whether or not leakage is within allowable limits. Locate and repair leaks at no additional cost to VBMU.
- B. The Engineer will certify successful completion of all required pressure and leakage tests before the pipeline is accepted by VBMU.

END SECTION 430 – TESTING OF SANITARY SEWER IMPROVEMENTS

THIS PAGE LEFT BLANK INTENTIONALLY

SECTION 510 – ELECTRICAL IMPROVEMENTS

PART 1 GENERAL

1.01 SCOPE OF WORK

- A. Furnish all labor, materials, equipment and incidentals required to install and test electrical, controls, instrumentation, and telemetry equipment for water and wastewater projects.
- B. Coordinate the installation, field testing, and commissioning of all electrical work with the City of Van Buren Municipal Utilities (VBMU), including installation of new electric service, pumping and other equipment, switchgear, electrical controls, telemetry, and emergency standby power equipment.

1.02 RELATED SECTIONS

- A. Section 520 – Emergency Standby Generator
- B. Section 530 – Automatic Transfer Switch
- C. Section 540 – Motor Control Center
- D. Section 550 – Telemetry and Instrumentation

1.03 REFERENCE STANDARDS

- A. Underwriters Laboratory (UL), latest edition:
 - 1. UL 6 Standard for Electrical Rigid Metal Conduit - Steel
 - 2. UL 6A Standard for Electrical Rigid Metal Conduit - Aluminum and Stainless Steel
 - 3. UL 360 Standard for Liquid-Tight Flexible Metal Conduit
 - 4. UL 514B Standard for Conduit, Tubing, and Cable Fittings
 - 5. UL 651 Standard for Schedule 40, 80, Type EB and A Rigid PVC Conduit and Fittings
 - 6. UL 797 Standard for Electrical Metallic Tubing - Steel
- B. American National Standards Institute (ANSI), latest edition:
 - 1. ANSI C80.1 Electric Rigid Steel Conduit (ERSC)
 - 2. ANSI C80.3 Electrical Metallic Tubing - Steel (EMT-S)
 - 3. ANSI C80.5 Electrical Rigid Metal Conduit - Aluminum (ERMC-A)

- C. American Society for Testing and Materials (ASTM), latest edition:
 - 1. ASTM F512 Standard Specification for Smooth-Wall Poly(Vinyl Chloride) (PVC) Conduit and Fittings for Underground Installation
- D. National Fire Protection Association (NFPA), latest edition:
 - 1. NFPA 70 National Electrical Code
- E. National Electrical Manufacturer Association (NEMA), latest edition:
 - 1. NEMA VE 1 Metal Cable Tray Systems
 - 2. NEMA MG 1 Motors and Generators

1.04 SUBMITTALS

- A. Submit shop drawings and product data to the Engineer for review for all electrical, controls, instrumentation, and telemetry to be used on a project.
- B. Submittal quantities shall be defined in the project specifications and conditions.

1.05 FEES, PERMITS, AND INSPECTIONS

- A. Obtain any and all required permits in connection with this work under the Contract and pay any and all fees in connection therewith. Arrange with the serving utility companies for the connections to all utilities and pay all charges for same including inspection fees and meters if required.
- B. Under this section of work the Contractor shall, upon completion of the work, furnish a certificate of final inspection to the Engineer from the inspection department having jurisdiction.

1.06 DELIVERY, STORAGE AND HANDLING

- A. Comply with manufacturer's ordering instructions and lead time requirements to avoid construction delays.
- B. Exercise care in loading, transporting and unloading to prevent injury to equipment.
- C. Store materials to protect from damage and exposure to harmful weather conditions.
- D. Equipment shall be covered and tightly sealed against the entrance of dust, dirt, and moisture.

1.07 COORDINATION

- A. Cooperate with all other trades to ensure the general progress of the work. Allow other trades access for the installation of their work and storage of materials.
- B. Schedule work according to the master schedule and follow the general construction closely.
- C. Work with other trades on the placement of equipment, such as conduits, fixtures, and outlets, to prevent interference with the installation of other work.

- D. The locations and elevations of equipment shown on the Drawings are approximate and may be subject to slight revisions as necessary at the time the work is installed. Final locations should be confirmed with the Engineer in advance of construction. Minor changes in location shall be made at no cost by the Contractor.
- E. Vary the sequence of construction as directed by the Engineer and in coordination with VBMU.

1.08 FIELD MEASUREMENTS

- A. Take field measurements at the site to verify or supplement indicated dimensions and to ensure proper coordination of all other construction items.

PART 2 PRODUCTS

2.01 GENERAL

- A. All materials shall conform to the standards referenced.
- B. All materials and equipment used on this project shall be new and of equal or greater quality than specified in the Drawings and Specifications.

2.02 RIGID STEEL CONDUIT (RSC)

- A. RSC shall be hot-dip galvanized steel. Threads shall be hot galvanized after cutting. RSC shall be produced in accordance with UL 6 and ANSI C80.1 and shall be listed by a nationally recognized testing laboratory with follow-up service.

2.03 ELECTRICAL METALLIC TUBING (EMT)

- A. EMT shall be steel, electrically welded, hot zinc galvanized and produced to ANSI Specifications C-80.3 and Federal Specification WW-C-563A latest revisions and shall carry the Underwriters Laboratories label.

2.04 LIQUIDTIGHT FLEXIBLE METALLIC CONDUIT (LFMC)

- A. The Type UL Liquidtight Flexible Steel Conduit shall be formed from a zinc coated galvanized low carbon steel strip having a uniform width and thickness. The construction shall be in accordance with UL 360 and CSA C22.2 Number 56 requirements. The finished Type LFMC dimensions shall be in accordance with Table 5.1 of UL 360.
- B. A rugged moisture, oil and sunlight resistant polyvinyl chloride (PVC) jacket shall be applied directly over the flexible metal conduit with a wall thickness in accordance with Table 4.1 of UL 360.

2.05 PVC NON-METALLIC CONDUIT

- A. Schedule-40 and Schedule-80 PVC Electrical Conduits shall be listed, in accordance with the National Electrical Code, for use with 90°C conductors in underground, above ground, encased, or exposed applications.

2.06 PVC COATED RIGID CONDUIT (CGRS)

- A. CGRS conduit must be UL Listed. The PVC coating must have been investigated by UL as providing the primary corrosion protection for the rigid metal conduit. Ferrous fittings for general service locations must be UL Listed with PVC as the primary corrosion protection. Hazardous location fittings, prior to plastic coating must be UL listed. All conduit and fittings must be new, unused material. Applicable UL standards may include UL 6 - Standard for Electrical Rigid Metal Conduit - Steel and UL 514B - Standard for Conduit, Tubing, and Cable Fittings.

2.07 RIGID ALUMINUM CONDUIT (RAC)

- A. RAC must be listed by Underwriters' Laboratories to UL 6A - Standard for Electrical Rigid Metal Conduit - Aluminum and Stainless Steel and be manufactured to ANSI C80.5.

PART 3 EXECUTION

3.01 INSTALLATION

- A. Holes for raceway penetration into sheet metal cabinets and boxes shall be made accurately with a hole punch. Cutting openings with a torch or other device will not be acceptable.
- B. Raceway entry into equipment shall be carefully planned. Cutting of the enclosure framework to accommodate poorly planned raceways will not be acceptable.
- C. Cabling inside equipment shall be carefully planned, routed, and laced. Cables shall be placed such that they do not cause obstruction.
- D. Equipment shall be set level and plumb. Equipment shall be braced and secured for a rigid fit.

3.02 EXCAVATION AND BACKFILLING

- A. The Contractor shall perform all excavation and backfilling necessary for the installation of the electrical system. The work shall include shoring and dewatering of ditches to keep them dry until the work has been installed. All shoring required to protect the excavation and safeguard employees shall be properly performed according to code.
- B. All excavations shall be made to the proper depth with allowances made for floor slabs, forms, beams, finished grades, etc. Ground under conduits shall be compacted prior to raceway installation.
- C. All backfill shall be made with selected soil, free of rocks and debris. The backfill shall be mechanically tamped in 6-inch layers to secure a 90% density ratio.
- D. All excavated material not suitable and not used in the backfill shall be removed to a disposal area as directed by the Engineer.
- E. Field check and verify all locations of underground utilities prior to any excavating. In the event existing utilities are broken, they are to be repaired to the original condition.
- F. Where the excavation requires the opening of existing walks, drives, or other existing equipment, these facilities shall be cut as required to facilitate the new construction. The sizes of the cut shall

be kept to a minimum. After installation is complete, repair the existing walks, drives, or other pavement to original condition or to match the new installation.

3.03 CUTTING AND PATCHING

- A. Cutting and patching required under this section shall be done in a workmanlike manner. Cutting lines shall be uniform and smooth.
- B. Use concrete saws for large cuts in concrete and use core drills for small round cuts in concrete.
- C. Where openings are cut through masonry walls, provide lintel or other structural supports to protect the existing masonry. Adequate support shall be provided during the cutting operation to prevent damage to the masonry.
- D. Patch concrete openings that are to be filled with nonmetallic, nonshrink grout. Finished concrete patching shall be smooth and shall be uniform with surrounding surfaces

3.04 FLASHING

- A. Provide waterproof flashing for each penetration of exterior walls and roofs.
- B. Flashing for conduit penetrations through built-up roofs shall be made with patch panel completely filled with pitch.

3.05 CLEANING AND TESTING

- A. Remove all temporary labels, dirt, paint, grease, and stains from all exposed equipment. Upon completion of work, clean equipment and the installation such as to produce a first class job suitable for occupancy. No loose parts or scraps of equipment shall be left at the site.
- B. Repair any scars to paint with kits supplied by the manufacturer.

END OF SECTION 510 – ELECTRICAL IMPROVEMENTS

THIS PAGE LEFT BLANK INTENTIONALLY

SECTION 520 – EMERGENCY STANDBY GENERATOR

PART 1 GENERAL

1.01 SCOPE OF WORK

- A. Provide a diesel fueled standby generator according to the specifications defined herein. Include generator manufacturer authorized startup and checkout after the generator has been installed by the Contractor. A written report will be required stating that the set has been installed according to factory requirements. Provide two (2) hours of training for City of Van Buren Municipal Utility personnel on the proper operation of the generator set (genset) at each site.
- B. Warranty papers shall reflect that factory warranty begins on the date of the approved authorized startup and checkout.
- C. The generator set must be fully fueled by the Contractor upon completion of acceptance testing.
- D. The generator manufacturer shall note in the proposal any other lubricants or fluids required to be provided by others for the generator set.
- E. Coordinate the installation, field testing, and commissioning of all emergency standby electrical equipment and controls with the City of Van Buren Municipal Utilities (VBMU), and coordinate all start up with the field testing and commissioning of the automatic startup switch.

1.02 RELATED SECTIONS

- A. Section 510 – Electrical Improvements
- B. Section 530 – Automatic Transfer Switch

1.03 REFERENCE STANDARDS

- A. Underwriters Laboratory (UL), latest edition:
 - 1. UL 142 Standard for Steel Aboveground Tanks for Flammable and Combustible Liquids
 - 2. UL 2200 Standard for Stationary Engine Generator Assemblies
- B. National Fire Protection Association (NFPA), latest edition:
 - 1. NFPA 70 National Electrical Code
 - 2. NFPA 110 Standard for Emergency and Standby Power Systems
- C. National Electrical Manufacturer Association (NEMA), latest edition:
 - 1. NEMA MG 1 Motors and Generators

- D. American National Standards Institute (ANSI), latest edition:
 - 1. ISO 8528-5 Reciprocating Internal Combustion Engine Driven Alternating Current Generator Sets

1.04 REGULATORY REQUIREMENTS

- A. The generator set shall be listed to UL 2200 - Standard for Stationary Engine Generator Assemblies.
- B. The generator set shall conform with NFPA 70 - National Electrical Code, and NFPA 110 - Standard for Emergency and Standby Power Systems.
- C. The generator set shall conform with NEMA MG-1 - Motors and Generators.

1.05 SUBMITTALS

- A. Six (6) complete equipment submittal packages are required to be provided with the proposal for the Engineer's evaluation and VBMU's consideration.
- B. Submit copies of all testing and commissioning reports to the Engineer.

1.06 WARRANTY

- A. The entire emergency standby generator set, including engine, alternator, controls, and accessories, shall be covered by a two (2) year limited warranty. The warranty shall include all parts, material, labor, and travel charges.

PART 2 PRODUCTS

2.01 MANUFACTURERS

- A. The manufacturer must maintain a company or vendor based service organization within a three (3) hour radius of the project site and shall be capable of coordinating emergency maintenance and repairs at the project site within twenty-four (24) hours maximum response time.
- B. The manufacturer model must be current production, commercial grade. The manufacturer must have been engaged in regular production of natural gas generator sets for a minimum of ten (10) years and be ISO 9001 certified. All proposed equipment must be new.

2.02 RATINGS

- A. The project ratings will indicate required voltage, phase, power factor, kW, kVA, and amps at 1000 feet altitude, -18C/40C ambient temperature, 0 to 100% RH condensing.

2.03 GENERATOR SET ENGINE

- A. The standby generator engine shall supply prime mover capability to power the ratings specified in Paragraph 2.02.A. and all accessories. The engine speed shall be 1800 RPM.
- B. The engine shall be diesel fueled, radiator and fan cooled.

- C. The engine induction system shall be air filters and be a replaceable dry element type air cleaner.
- D. The engine fuel system shall be designed for operation on No. 2 diesel fuel. A primary fuel filter, water separator, manual fuel priming pump, fuel shutoff solenoid and all fuel lines must be installed at the point of manufacture.
- E. The engine speed shall be controlled by electronic governor to maintain alternator frequency. Steady state regulation is to be +/- 0.5%.
- F. The engine oiling system shall be provided by a positive displacement, mechanical, full pressure lubrication oil pump. Oil filtering shall be full flow lubrication oil filter with replaceable spin on canister element and dipstick oil level indicator.
- G. A 12 VDC electric starter system capable of three (3) complete cranking cycles of engine without overheating shall be integral to the engine.
- H. Engine mounted battery charging alternator, ampere as per the manufacturer design, and solid state voltage regulator shall be located as necessary such that output is available to charge the starting batteries when the engine is operating.
- I. The primary diesel fuel filter shall be capable of removing contaminants of 10 microns. Element shall be replaceable paper type.
- J. The engine shall have cold weather kits for heating the coolant fluid and maintaining optimal battery temperature, per the specified ambient temperature limit.
- K. The engine shall incorporate a liquid cooled, closed loop engine radiator system.
- L. The radiator shall be mounted on the engine generator base with integral engine driven circulating pump and engine driven cooling fan.
- M. The radiator and cooling system shall be rated for full load operation in rated ambient temperature as measured at the generator air inlet.
- N. The cooling system shall be filled with 50/50 ethylene glycol/water mixture.
- O. Rotating parts shall be guarded against accidental contact.
- P. Flexible fuel supply lines shall be provided with 12-inch minimum length.
- Q. Oil and coolant drain lines shall be extended to the genset base rail.
- R. The engine shall include a coolant heater at 120/240 VAC with sufficient wattage to allow the engine to start and operate down to -18°C. The Contractor shall install a proper power supply circuit for the heater as required for the voltage and load of the heater, connected to a normally served distribution circuit.
- S. Sensing elements to be located on the engine for low oil pressure shutdown, high coolant temperature shutdown, overspeed shutdown and overcrank protection.
- T. The exhaust muffler shall be provided of the size as recommended by the manufacturer and shall be of critical grade. The silencer shall be mounted externally or within the weather protective

enclosure for reduced exhaust noise. It shall be connected to the engine with a flexible, seamless, stainless steel exhaust connection.

- U. The fuel system shall include a double wall base mounted fuel tank. It shall have a stub-up area convenient for electrical conduit entry. It shall have the structural integrity to support the engine-generator set and carry the UL 142 mark. Minimum features shall include all welded construction, a lockable fuel filler cap, fuel gauge, low fuel level alarm, fuel line check valve, vent and fittings for fuel supply, return, fill and emergency vent. This tank must be supplied by the engine-generator set manufacturer and be installed before shipment. The size of the fuel tank shall allow for 24 hour continuous operation at generator set full load.
- V. Vibration isolators shall be provided between the engine-generator and welded steel base or between the base and the fuel tank.

2.04 GENERATOR SET ALTERNATOR

- A. The alternator shall be a synchronous, four pole, 2/3 pitch, revolving field, drip-proof construction, air cooled by a direct drive centrifugal blower fan, and a pre-lubricated sealed bearing design with flexible drive disc coupling directly connected to the engine. All insulation system components shall meet NEMA MG 1 temperature limits for Class H insulation system.
- B. The alternator shall be capable of delivering rated genset output kW at rated frequency and power factor at not more than 5 percent (5%) above or below rated voltage.
- C. The generator set transient response from no load to full load, and full load to no load in one (1) step shall not exceed the voltage dip, voltage overshoot, and voltage recovery as defined in ISO 8528-5.
- D. Sustained short circuit currents shall be in conformance with NEMA Standards.
- E. The neutral connection when provided, shall be electrically isolated from equipment ground and terminated in same junction box as the phase conductors.
- F. The alternator shall be equipped with a brushless rotating exciter system.
- G. The alternator shall be designed for sustained operation at 125% of the RPM specified for the engine generator set without damage.
- H. A thermostatically controlled space heater shall be provided within the alternator to maintain the stator windings above the dew point. The heater shall be sized and mounted in a location as recommended by the alternator manufacturer.
- I. The engine generator set shall include an automatic voltage regulator that is matched and tested with the engine governing system provided. The regulator shall be immune from mis-operation due to load induced voltage waveform distortion and provide a regulated output to the alternator exciter.
- J. The voltage regulation system shall be equipped with RMS phase sensing and shall control buildup of AC generator voltage to provide a linear rise and limit overshoot. The system shall include a function to reduce output voltage in proportion to frequency below a threshold of 58 to 59 HZ. The voltage regulator shall include adjustments for gain, damping, and frequency roll off. Adjustments shall be broad range and made via trim pots or digital raise-lower switches.

- K. The voltage regulator must be used to control output voltage by varying the exciter magnetic field to provide + or – 1.0% regulation during stable load conditions.
- L. A main circuit breaker shall be provided, sized by the manufacturer for voltage, phase, and ampacity. The line side connections are to be made at the factory. Output lugs shall be provided for load side connections.

2.05 GENERATOR SET CONTROLS

- A. The control system shall be mounted within the generator set and provide a suitable operator control panel. The control panel shall provide vibration isolation as necessary to the mounted controls to provide trouble free operation.
- B. Manual and automatic starting/stopping of the generator set shall be provided. Manual starting shall be from the operator panel. Automatic starting shall be provided from remote two (2) wire system.
- C. Monitoring and control functions for the generator set shall be provided. Local monitoring shall be at the operator panel. The controller shall include the capability for future remote monitoring, either by serial or Ethernet connection.
- D. The controller shall include automatic annunciation or shutdown of generator set warning or alarm functions.
- E. The control system shall include an engine cycle cranking system with adjustable settings for pre-start delay, maximum crank time, pause time between crank attempts, and idle time.
- F. The control system shall have a manual output voltage adjustment available from the operator control panel. The manual adjustment may be made by rotating a panel mounted potentiometer or alternatively with the use of an increase/decrease increment switch.
- G. The engine control shall include an E-STOP, a MAN/OFF/AUTO switch, an LCD display to provide generator status indication and annunciation of all warning and shutdown faults, and a method of data entry change via keypad or other means.
- H. The control system shall include two (2) Form A relay contacts to annunciate Generator Running and Generator Alarm/Fault to the VBMU SCADA system.

2.06 GENERATOR SET ACCESSORIES

- A. The generator set shall include a Level 2 sound attenuated enclosure and shall be factory assembled to generator set base. The enclosure shall limit the sound levels from 63 to 78 d(B)A when measured with microphones placed at 23 feet from the enclosure at 45 degree angles. The enclosure shall provide ample airflow for generator set operation at rated load in the ambient conditions specified. The housing shall have hinged side access doors and all doors shall be lockable. All sheet metal shall be primed for corrosion protection and finish painted with the manufacturer's standard color using an electro-coating paint process.
- B. The enclosure air discharge hood shall be mounted in front of the unit mounted radiator and include an integral punched screen air discharge barrier mounted in front of the normal radiator area to protect from birds and debris. The discharge hood shall be lined with acoustic foam

insulation and includes a rain gutter to channel water away from the genset interior. The discharge hood and air discharge barrier shall be made of the same enclosure material to complement the genset exterior.

- C. A heavy duty, lead acid 12VDC battery set shall be installed by the generator set manufacturer. Provide all intercell and connecting battery cables as required.
- D. Provide an automatic battery charger manufactured by the engine-generator set supplier. The output voltage is to be determined by the charge current rate. The charger must be protected against a reverse polarity connection. The battery charger is to be factory installed on the generator set.
- E. The generator set shall be provided with vibrations isolators between the engine/alternator and generator set base. Vibration isolators shall be provided in a quantity as recommended by the generator set manufacturer to provide suitable isolation to reduce the vibration to the surrounding area. The isolators shall be of the spring type construction.

PART 3 EXECUTION

3.01 FACTORY TESTING

- A. Before shipment of the equipment, the engine-generator set shall be tested under rated load for performance and proper functioning of control and interfacing circuits. Tests shall include:
 - 1. Verifying all safety shutdowns are functioning properly.
 - 2. Verify transient and voltage dip responses and steady state voltage and speed (frequency) checks.
 - 3. Two (2) sets of owner's manuals specific to the product supplied must accompany delivery of each generator set. General operating instruction, preventive maintenance, wiring diagrams, schematics and parts exploded views specific to this model must be included.

3.02 ON-SITE TESTING

- A. Perform the following minimum tests with the Engineer and VBMU:
 - 1. Ensure the engine starts (both hot and cold) within the specified time.
 - 2. Verification of engine parameters within specification.
 - 3. Verify no load frequency and voltage, adjust if required.
 - 4. Test all automatic shutdowns of the engine-generator.
 - 5. Perform a load test of the generator set, ensuring full load frequency and voltage are within specification by using site load.

END OF SECTION 520 – EMERGENCY STANDBY GENERATOR

SECTION 530 – AUTOMATIC TRANSFER SWITCH

PART 1 GENERAL

1.01 SCOPE OF WORK

- A. Provide the quantity, rating, and type of Automatic Transfer Switch (ATS) defined for the project.
- B. Include all freight and unloading to the site. Provide protective wrappings, containers, or other protection to exclude dirt and moisture while in transit.
- C. Include authorized startup and checkout in conjunction with the generator testing. A written report will be required stating that the set has been installed according to factory requirements. Provide training on operation of the switch at the same time the generator training is provided.
- D. Warranty papers shall reflect that factory warranty begins on the date of the approved authorized startup and checkout.
- E. Coordinate the installation, field testing, and commissioning of the automatic transfer switch with the City of Van Buren Municipal Utilities (VBMU), and coordinate all start up with the field testing and commissioning of the emergency standby generator.

1.02 RELATED SECTIONS

- A. Section 510 – Electrical Improvements
- B. Section 520 – Emergency Standby Generator

1.03 REFERENCE STANDARDS

- A. Underwriters Laboratory (UL), latest edition:
 - 1. UL 142 Standard for Steel Aboveground Tanks for Flammable and Combustible Liquids
 - 2. UL 1008 Standard for Transfer Switch Equipment
 - 3. UL 2200 Standard for Stationary Engine Generator Assemblies
- B. National Electrical Manufacturer Association (NEMA), latest edition:
 - 1. NEMA 250 Enclosures for Electrical Equipment (1,000 Volts Maximum)
- C. National Fire Protection Association (NFPA), latest edition:
 - 1. NFPA 70 National Electrical Code
 - 2. NFPA 110 Standard for Emergency and Standby Power Systems

1.04 REGULATORY REQUIREMENTS

- A. The ATS shall conform with UL 1008 - Standard for Transfer Switch Equipment.
- B. The ATS shall conform with NFPA 70 - National Electrical Code and NFPA 110 - Standard for Emergency and Standby Power Systems.

1.05 SUBMITTALS

- A. Six (6) complete equipment submittal packages are required to be provided with the proposal for the Engineer's evaluation and VBMU's consideration.

1.06 WARRANTY

- A. The ATS shall be covered by a two (2) year limited warranty. The warranty shall include all parts, material, labor, and travel charges.

PART 2 PRODUCTS

2.01 MANUFACTURERS

- A. Where shown on the project Drawings, Automatic Transfer Switches shall be service entrance rated. Construction of service entrance rated switches shall include a service disconnect for the utility entrance with mechanically interlocked contactors for the switching device. Switches that utilize mechanically actuated circuit breakers for both utility and emergency feeds are not allowed. Stored energy circuit breakers for large ampacity switches are allowed.

2.02 RATINGS

- A. Ratings for voltage, phase, amps, and NEMA enclosure, plus any accessories, are defined within the specification.

2.03 MECHANICALLY HELD TRANSFER SWITCH

- A. The transfer switch unit shall be electrically operated and mechanically held. The electrical operator shall be a single-solenoid mechanism, momentarily energized. Main operators which include overcurrent disconnect devices will not be accepted. The switch shall be mechanically interlocked to ensure only one (1) of two (2) possible positions, normal or emergency.
- B. The switch shall be positively locked and unaffected by momentary outages so that contact pressure is maintained at a constant value and temperature rise at the contacts is minimized for maximum reliability and operating life.
- C. All main contacts shall be silver composition. Switches rated 600 amperes and above shall have segmented, blow-on construction for high withstand current capability and be protected by separate arcing contacts.
- D. Inspection of all contacts shall be possible from the front of the switch without disassembly of operating linkages and without disconnection of power conductors. A manual operating handle shall be provided for maintenance purposes. The handle shall permit the operator to manually stop the contacts at any point throughout their entire travel to inspect and service the contacts when required.

- E. Designs utilizing components of molded-case circuit breakers, contactors, or parts thereof which are not intended for continuous duty, repetitive switching or transfer between two (2) active power sources are not acceptable.
- F. Where neutral conductors must be switched, the ATS shall be provided with fully-rated neutral transfer contacts.
- G. Where neutral conductors are to be solidly connected, a neutral terminal plate with fully-rated AL-CU pressure connectors shall be provided.

2.04 TRANSFER SWITCH MICROPROCESSOR CONTROLLER

- A. The controller shall direct the operation of the transfer switch. The controller's sensing and logic shall be controlled by a built-in microprocessor for maximum reliability, minimum maintenance, and inherent serial communications capability. The controller shall be connected to the transfer switch by an interconnecting wiring harness. The harness shall include a keyed disconnect plug to enable the controller to be disconnected from the transfer switch for routine maintenance.
- B. The controller shall be enclosed with a protective cover and be mounted separate from the transfer switch unit for safety and ease of maintenance. Sensing and control logic shall be provided on printed circuit boards. Interfacing relays shall be industrial grade plug-in type with dust covers.

2.05 ENCLOSURES

- A. Outdoor installations shall be provided with NEMA Type 3R Secure or NEMA Type 4 Secure enclosures as specified by the product model number.
- B. Indoor installations shall be provided with NEMA Type 1 or NEMA Type 12 enclosures as specified by the product model number.

2.06 ACCESSORIES

- A. The transfer switches shall be provided with programmable engine exerciser for weekly operation.
- B. The transfer switches shall be provided with strip heater and thermostat for all outdoor installations.
- C. The transfer switches shall be provided with integral transient voltage surge suppression (TVSS) that protects the switch and sensing circuitry from harmful voltage events. The TVSS must protect the sensing circuit of the Normal utility voltage, even while the switch is Emergency position.

2.07 DISCONNECT AND OVERCURRENT PROTECTION DEVICE

- A. For those automatic transfer switches less than 1000 amperes, the normal connection shall be provided with a thermal magnetic rated molded case circuit breaker with current ratings as shown on the Drawings. It shall have a thermal magnetic trip unit.
- B. For those automatic transfer switches rated above 1000 amperes, the normal connection shall be provided with a stationary mount, insulated case circuit breaker with a solid-state trip unit. The trip unit shall have an adjustable long time, short time, instantaneous, and ground fault trip settings. The insulated case circuit breaker shall trip open when the ground fault setting is exceeded.

- C. The withstand and close ratings shall be 22kA for devices 200A and below, 42kA for devices to 400A, and 65kA for devices to 1200A.

PART 3 EXECUTION

3.01 VOLTAGE AND FREQUENCY

- A. The voltage of each phase of the normal source shall be monitored, with pickup adjustable to 95% of nominal and dropout adjustable from 70% to 90% of pickup setting.
- B. Single-phase voltage and frequency sensing of the emergency source shall be provided.

3.02 TIME DELAYS

- A. An adjustable time delay shall be provided to override momentary normal source outages and delay all transfer and engine starting signals.
- B. An adjustable time delay shall be provided on transfer to emergency, adjustable from 0 to 5 minutes for controlled timing of transfer of loads to emergency.
- C. A generator stabilization time delay shall be provided after transfer to emergency.
- D. An adjustable time delay shall be provided on retransfer to normal, adjustable to 30 minutes. Time delay shall be automatically bypassed if emergency source fails and normal source is acceptable.
- E. A 5-minute cooldown time delay shall be provided on shutdown of engine generator.
- F. All adjustable time delays shall be field adjustable without the use of special tools.

3.03 ADDITIONAL FEATURES

- A. A set of contacts rated 5 amps, 32 VDC shall be provided for a low-voltage engine start signal. The start signal shall prevent dry cranking of the engine by requiring the generator set to reach proper output and run for the duration of the cool down setting, regardless of whether the normal source restores before the load is transferred.
- B. A push-button type test switch shall be provided to simulate a normal source failure.
- C. A push-button type switch to bypass the time delay on transfer to emergency, the engine exerciser period on the retransfer to normal time delay whichever delay is active at the time the push-button is activated.
- D. Terminals shall be provided for a remote contact which opens to signal the ATS to transfer to emergency and for remote contacts which open to inhibit transfer to emergency and/or retransfer to normal.
- E. Form A contacts shall be provided to annunciate ATS in Utility and ATS in Emergency to the VBMU SCADA system.

- F. Indicating lights shall be provided, one (1) to indicate when the ATS is connected to the normal source (green) and one (1) to indicate when the ATS is connected to the emergency source (red). Also provide indicating lights for both normal and emergency source availability.
- G. Terminals shall be provided to indicate actual availability of the normal and emergency sources, as determined by the voltage sensing pickup and dropout settings for each source.
- H. Engine Exerciser - An engine generator exercising timer shall be provided, including a selector switch to select exercise with or without load transfer.
- I. Inphase Monitor - An Inphase monitor shall be inherently built into the controls. The monitor shall control transfer so that motor load inrush currents do not exceed normal starting currents and shall not require external control of power sources.

END OF SECTION 530 – AUTOMATIC TRANSFER SWITCH

THIS PAGE LEFT BLANK INTENTIONALLY

SECTION 540 – MOTOR CONTROL CENTER

PART 1 GENERAL

1.01 SCOPE OF WORK

- A. Furnish and install a motor control center (MCC) for the pump station as shown on the Drawings and as specified herein. Unless otherwise specified, all MCCs shall be 480/277V, 3-Phase, 4-Wire, 60 Hz.
- B. Coordinate the installation, field testing, and commissioning of the motor control center with the City of Van Buren Municipal Utilities (VBMU), including any start up involving telemetry improvements.

1.02 RELATED SECTIONS

- A. Section 510 – Electrical Improvements
- B. Section 550 – Telemetry

1.03 REFERENCE STANDARDS

- A. Underwriters Laboratory (UL), latest edition:
 - 1. UL 50 Standard for Enclosures for Electrical Equipment, Non-Environmental Considerations
 - 2. UL 67 Standard for Panelboards
 - 3. UL 508 Standard for Industrial Control Equipment
 - 5. UL 845 Motor Control Centers
 - 6. UL 1283 Standard for Electromagnetic Interference Filters
 - 7. UL 1449 Standard for Surge Protective Devices
 - 4. UL 61800-5-1 Adjustable Speed Electrical Power Drive Systems
- B. National Electrical Manufacturer Association (NEMA), latest edition:
 - 1. NEMA ICS 3 Instructions for the Handling, Installation, Operation and Maintenance of Motor Control Centers Rated Not More Than 600 V
- C. National Fire Protection Association (NFPA), latest edition:
 - 1. NFPA 70 National Electrical Code
 - 2. NFPA 110 Standard for Emergency and Standby Power Systems

1.04 SUBMITTALS

- A. Submit in accordance with project requirements.
- B. Submittals are required for the following:
 - 1. MCC One - Line Diagram
 - 2. MCC Elevation
 - 3. MCC Conduit Entry and Clearance, Top and Bottom
 - 4. MCC Control and Wiring Diagrams
 - 5. Power Monitor Information and Wiring Details

1.05 O&M MANUALS

- A. Provide MCC O&M Manuals in accordance with project requirements.
- B. O & M Manuals must include all information from 1.04.B and the following additional information:
 - 1. MCC Maintenance Procedures
 - 2. MCC Spare Parts Requirements
 - 3. Power Monitor User Manuals
 - 4. Transient Voltage Surge Suppression (TVSS) User Manuals

1.06 PACKING/SHIPPING

- A. The MCC shall be separated into shipping blocks no more than three vertical sections each. Shipping blocks shall be shipped on their sides to permit easier handling at the jobsite. Each shipping block shall include a removable lifting angle, which will allow an easy means of attaching an overhead crane or other suitable lifting equipment.

1.07 STORAGE

- A. The MCC must be stored in a clean and dry environment after shipment to the jobsite, free from temperature extremes.

1.08 WARRANTY

- A. The MCC shall be warranted to be free from defects in materials and workmanship for a period of one (1) year from the date of completion and acceptance by VBMU.

PART 2 PRODUCTS

2.01 MANUFACTURERS

- A. The MCC shall be manufactured by Cutler-Hammer, Square D Company, Allen-Bradley Company, General Electric, or approved equal.

2.02 MATERIALS

- A. Steel material shall comply with UL 845 and CSA requirements.
- B. Each MCC shall consist of one (1) or more vertical sections of heavy gauge steel bolted together to form a rigid, free-standing assembly. A removable 7-gauge structural steel lifting angle shall be mounted full width of the MCC lineup at the top. Removable 7-gauge bottom channel shall be mounted underneath front and rear of the vertical sections extending the full width of the lineup. Vertical sections shall be made of welded side-frame assembly formed from a minimum of 12-gauge steel. Internal reinforcement structural parts shall be of 11-gauge steel to provide a strong, rigid assembly. The entire assembly shall be constructed and packaged to withstand all stresses included in transit and during installation.

2.03 MCC FINISH

- A. All steel parts shall be provided with UL and CSA listed acrylic/alkyd baked enamel paint finish, except plated parts used for ground connections.

2.04 STRUCTURES

- A. Structures shall be totally enclosed, dead-front, free-standing assemblies. Structures shall be capable of being bolted together to form a single assembly.
- B. The overall height of the MCC shall not exceed 90 inches. The total width of one (1) standard section shall be 20 inches. Specialty sections shall have maximum width as detailed on the Drawings.
- C. Structures shall be NEMA/EEMAC 1 general purpose.
- D. Each 20 inch wide standard section shall have all necessary hardware and bussing for modular plug-in units to be added and moved around. All unused space shall be covered by hinged blank doors and equipped to accept future units. Vertical bus openings shall be covered by manual bus shutters.
- E. Each section shall include a top plate. The plate will be removable for ease in cutting conduit entry openings.

2.05 WIREWAYS

- A. Structures shall contain a minimum of 12 inches high horizontal wireway at the top of each section and a minimum of 6 inches high horizontal wireway at the bottom of each section. These wireways shall run the full length of the MCC to allow room for power and control cable to connect between units in different sections.
- B. A full-depth vertical wireway shall be provided in each MCC section that accepts modular plug-

in units. The vertical wireway shall connect with both the top and bottom horizontal wireway and shall be isolated from unit interiors by a full height barrier. The vertical wireway shall be 4 inches wide minimum with a separate hinged door. Access to the wireways shall not require opening control unit doors.

2.06 BARRIERS

- A. All power bussing and splice connections shall be isolated from the unit compartments and the wireways. The horizontal bus shall be mounted onto a glass filled polyester support assembly that braces the bus against the forces generated during a short circuit. The horizontal bus shall be isolated from the top horizontal wireway by a two (2) piece grounded steel barrier. The barrier shall be removable to allow access to the bus and connections for maintenance.
- B. The vertical bus shall be housed in a molded glass filled polyester support that provides bus insulation and braces the bus against the forces generated during a short circuit. These supports shall have openings every 3 inches for unit stab-on connections. Each opening shall be provided with a manual shutter to close off the stab opening. These shutters shall be attached to the structure so that when they are removed, they are retained in the structure and are readily accessible for use should a plug-in unit be removed from the MCC.
- C. Barriers shall be provided in the vertical structure and unit designs to prevent the contact of any energized bus or terminal by a fishtape inserted through the conduit or wireway areas.

2.07 BUSSING

- A. All bussing and connectors shall be tin-plated or silver-plated copper.
- B. The main horizontal bus shall be rated 600A, 800A, 1200A, or 1600A continuous and shall extend the full length of the MCC. Bus ratings shall be based on 65C maximum temperature rise in a 40C ambient environment. Provisions shall be provided for splicing additional sections onto either end of the MCC.
- C. The horizontal bus splice bars shall be pre-assembled into a captive bus stack. The bus stack is installed into the end of the MCC power bus to allow the installation of additional sections. The main bus splice shall utilize four (4) bolts, two (2) on each side of the bus, for each phase. Additional bolts must not be required when splicing higher amperage bus. The splice bolts shall secure to self-clenching nuts installed in the bus assembly. It shall be possible to maintain any bus connection with a single tool. Nut and bolt bus connections to the power bus shall not be permitted.
- D. Each section that accepts plug-in units shall be provided with a vertical bus for distributing power from the main bus to the individual plug-in starter units. This bus shall be of the same material as the main bus. The vertical bus shall be connected directly to the horizontal bus stack without the use of risers or intervening connectors. It shall be possible to maintain the vertical to horizontal bus connection with a single tool. Nut and bolt bus connections to the power bus shall not be permitted.
- E. A tin-plated copper ground bus shall be provided that runs the entire width of the MCC. A compression lug shall be provided in the MCC for a 4/0 – 250 kcmil ground cable. The ground bus shall be provided with six 0.38 inch holes for each vertical section to accept customer supplied ground lugs for any loads requiring a ground conductor.

- F. Each vertical section shall have a copper vertical ground bus that is connected to the horizontal ground bus. This vertical ground bus shall be installed so that the plug-in units engage the ground bus prior to engagement of the power stabs and shall disengage only after the power stabs are disconnected upon removal of the plug-in unit.
- G. The power bus system shall be braced for a short circuit capacity of 42,000 rms amperes minimum as standard. Bus bracing rated at 65,000, 85,000, and 100,000 rms amperes shall be available.

2.08 UNIT CONSTRUCTION

- A. Units with circuit breaker disconnect through 400A frame, and fusible switch disconnects through 400A, shall connect to the vertical bus through a spring reinforced stab-on connector. Units with large disconnects shall be connected directly to the main horizontal bus with appropriately sized cable or riser bus. Stabs on all plug-in units shall be solidly bussed to the unit disconnect.
- B. All conducting parts on the line side of the unit disconnect shall be shrouded by a suitable insulating material to prevent accidental contact.
- C. Unit mounting shelves shall include hanger brackets to support the unit weight during installation and removal.
- D. A cast metal handle operator must be provided for each disconnect. With the unit stabs engaged into the vertical phase bus and the unit door closed, the handle mechanism shall allow complete ON/OFF control of the unit disconnect with clear indication of the disconnect status. All circuit breaker operators shall include a separate TRIPPED position to clearly indicate the circuit breaker tripped condition. It shall be possible to reset a tripped circuit breaker without opening the control unit door.
- E. A mechanical interlock shall prevent the operator from opening the unit door when the disconnect is in the ON position. Another mechanical interlock shall prevent the operator from placing the disconnect in the ON position while the unit door is open. It shall be possible for authorized personnel to defeat these interlocks.
- F. A non-defeatable interlock shall be provided between the handle operator and the cam lever to prevent installing or removing a plug-in unit unless the disconnect is in the OFF position.
- G. The plug-in unit shall have a grounded stab-on connector which engages the vertical ground bus prior to, and releases after, the power bus stab-on connectors.
- H. Provisions shall be provided for locking all disconnects in the OFF position with up to three padlocks.
- I. Unit construction shall combine with vertical wireway isolation barrier to provide a fully compartmentalized design.

2.09 COMBINATION MOTOR STARTERS

- A. All combination starters shall use a unit disconnect as previously specified. All starters shall utilize NEMA rated contactors except where noted on the Drawings. Starters shall be provided with a solid state three pole, external manual reset, overload relay. The overload relays shall provide integral isolated normally open and normally closed contacts.

- B. Auxiliary control circuit interlocks shall be provided where indicated. A minimum of two (2) normally open contacts shall be provided with each contactor.
- C. Each unit will wire directly to terminal blocks for motor and control wiring. Terminal blocks shall all be rated at 600 volts and at the ampacity required for the loads.
- D. When provided, control power transformers shall include two (2) primary and one (1) secondary fuse. The transformer shall be sized to power the contactor and all connected loads.
- E. Controls for the motor starters shall be as indicated on the Drawings.
- F. All combination starters shall include elapsed time meters (ETM).
- G. All combination starters shall be provided with HAND-OFF-AUTO switches.
- H. All combination starters shall be provided with green RUN indication pilot lights.

2.10 BRANCH FEEDER UNITS

- A. Unless otherwise specified on the Drawings, all branch feeder units shall be circuit breaker type with interrupting capacity equal to the bus bracing capacity shown on the Drawings.

2.11 TRANSIENT VOLTAGE SURGE SUPPRESSOR (TVSS)

- A. The MCC shall be provided with an integral TVSS. The manufacturer of the TVSS shall be the same as the manufacturer of the MCC
- B. The TVSS shall be listed and recognized in accordance with UL 1449.
- C. The TVSS must be supplied with a UL recognized circuit breaker or fusible disconnect switch and shall connect directly to the MCC vertical bus.
- D. The TVSS shall provide surge current protection for all modes of protection: Line to Line, Line to Neutral, and Line to Ground.
- E. The TVSS shall have a peak surge current rating of 160 kA per phase.
- F. The TVSS shall be rated for 480Y/277 VAC, 3 Phase, 4 Wire system voltage.
- G. The TVSS shall have UL suppression voltage rating of 800V Line-Neutral, 800V Line-Ground, and 1600V Line-Line. The TVSS shall have a maximum continuous operating voltage of 320V.
- H. The TVSS shall be supplied with an optional surge counter with reset button.
- I. The TVSS shall be provided with a form C contact which shall indicate a failure of a phase or the entire unit.

2.12 POWER CIRCUIT MONITOR

- A. The power monitor setup parameters will be stored in nonvolatile memory and retained in the event of a power interruption.

- B. The power monitor will be programmed to provide one (1) Form C output to annunciate an Undervoltage, Overvoltage, or Phase Loss Fault. The contact shall be closed state on alarm.
- C. The power monitor will be applied in 480/277V, three phase, four wire systems.
- D. The power monitor will provide real time RMS values of the following parameters:
 - 1. Voltage (Line to Line per Phase, Line to Line 3 Phase Average, Line to Neutral per Phase)
 - 2. Real Power (3 Phase Total)
 - 3. Reactive Power (3 Phase Total)
 - 4. Apparent Power (3 Phase Total)
 - 5. Power Factor (3 Phase Total)
 - 6. Frequency
 - 7. Total Harmonic Distortion (THD), Current and Voltage
 - 8. Current (Per phase, Neutral, Ground, 3 Phase Average)

2.13 SOLID STATE SOFT STARTERS (SSS)

- A. The SSSs shall be standard items, mounted into MCC buckets with accessories as defined herein.
- B. The SSS shall have output ampacity ratings as shown on the Drawings.
- C. The SSS shall have integrated bypass contactor.
- D. The SSS shall have integrated motor overload protection.
- E. The SSS shall provide soft start, kickstart, and current limit methods of starting standard NEMA motors.
- F. The SSS shall have an integral HMI for diagnostic status and fault alarms.
- G. The SSS shall have an integral HMI display for operation parameter programming.

2.14 VARIABLE FREQUENCY DRIVES (VFD)

- A. The VFDs shall be standard items, mounted into MCC buckets with accessories as defined herein.
- B. The VFD will be pulse with modulation (PWM) technology.
- C. The VFD shall be rated by continuous output current as shown on the Drawings. The VFD rating shown on the Drawings is a minimum. Do not rate the VFD to motor horsepower shown on the Drawings.
- D. The VFD shall be capable of continuous operation at 110% output current rating.

- E. The VFD shall operate variable torque loads unless otherwise indicated.
- F. The VFD must operate in an ambient temperature from 0 to 40°C.
- G. The VFD must operate in humidity conditions up to 93% at 40°C, non-condensing.
- H. The VFD must operate at an input voltage of 480 VAC +/- 10% without fault.
- I. The VFD must operate from an input frequency range of 57 to 63 Hz.
- J. The VFD efficiency shall be 97% minimum.
- K. The output carrier frequency shall be adjustable from .5 and 10 kHz.
- L. The VFD shall be capable of open loop torque control with sensorless flux vector algorithms. The VFD default setting shall be vector control. The VFD will be able to develop rated motor torque at 0.5 Hz (60 Hz base) in a sensorless flux vector (SVC) mode using a standard induction motor without an encoder feedback signal.
- M. The VFD shall have protection functions for output phase short circuits, ground faults, logic and analog output faults, overtemperature, and internal power supply faults.
- N. The VFD shall have solid state overload protection that is UL 61800-5-1 listed for Class 10 overload protection. The overload protection shall be adjustable to the driven motor full load nameplate value.
- O. The VFD shall be setup to automatically reset on all faults other than ground fault, short circuit, or internal fault.
- P. The VFD shall be setup to ride through a power loss or fluctuation.
- Q. The VFD shall have a programmable skip frequency.
- R. The VFD shall be setup to reduce frequency when an overload condition is detected.
- S. The VFD shall have programmable form C contacts for VFD Fault and VFD Run. The contacts shall be interposed through an internal control relay to provide for Normally Open or Normally Closed contact for the local Telemetry system.
- T. The VFD shall have a minimum of two (2) analog speed reference inputs, one (1) for a potentiometer in the HAND mode of operation, and one (1) for a 4-20mA input for AUTO mode of operation.
- U. The VFD shall be supplied with a keypad, mounted on the door. The keypad shall provide the ability to adjust all programming parameters. The keypad shall include at least two (2) lines of forty character text, with the capability of monitoring volts, amps, frequency, speed reference, and other VFD monitor functions.
- V. The VFD shall have adjustable acceleration and deceleration parameters with linear/S curve switchable patterns.
- W. The VFD start/stop and speed reference will be controlled via terminal inputs on the VFD.

- X. The VFD shall be provided with an integral 3% line reactor.
- Y. The VFD shall be supplied with the following operator controls.
 - 1. Industrial rated 22mm type control operators and pilot devices shall be door mounted and used independently of the keypad display to select operator control modes of LOCAL-REMOTE.
 - 2. The VFD shall be provided with a HAND-OFF-AUTO (HOA) three position selector switch. In the HAND position, the VFD will run and override any local alarms but will not run if faulted. In the AUTO position, the VFD will run from a voltage free contact from the local PLC system. An additional voltage free contact shall be provided in the AUTO position to provide a verification input to the local PLC system that the VFD is in AUTO position.
 - 3. The HAND mode of operation shall a VFD mounted potentiometer for speed reference. The AUTO mode of operation shall use the VFD 4-20mA input for speed reference.
 - 4. OFF - The Off position of the control operator shall stop the AC drive and prevent it from restarting while in the Off position.
 - 5. The VFD shall include door-mounted “VFD Run” and “VFD Fault” pilot lights. All pilot lights shall be Push-to-Test configurations.

2.15 TRANSFORMERS

- A. All insulating materials are to exceed NEMA ST20 standards and be rated for 220 degrees C UL component recognized insulation system.
- B. Transformers 15 kVA and larger shall be 150 degrees C temperature rise above 40 degrees C ambient. The transformer shall have a minimum of 4 – 2.5% full capacity primary taps.
- C. The maximum temperature at the top of the MCC bucket shall not exceed 50 degrees C rise above 40 degrees C ambient.
- D. The transformer shall be rated and identified with model number, kVA rating, Voltages, Phase, and Frequency.
- E. Transformer coils shall be of continuous wound construction and shall be impregnated with nonhygroscopic thermosetting varnish.
- F. All cores shall be constructed with low hysteresis and eddy current losses.
- G. The core of the transformer shall be visibly grounded.
- H. The transformer section shall be adequately ventilated to prevent overheating.

2.16 PANELBOARDS

- A. Interior
 - 1. Lighting and Appliance (LP) panelboards shall be rated for 120/240 VAC, single phase, three

wire, ampacity as shown on the Drawings.

2. Power panelboards (PP) shall be rated for 480/277 VAC, three phase, four wire, ampacity as shown on the Drawings.
3. The minimum short circuit current rating shall be 10,000 rms symmetrical amperes at 240 VAC for lighting and appliance panelboards.
4. The minimum short circuit current rating shall be 22,000 rms symmetrical amperes at 480 VAC for power panelboards.
5. Provide one (1) continuous bus bar per phase. Each bus bar shall have sequentially phased branch connectors suitable for bolt-on branch circuit breakers. The bussing shall be fully rated. Panelboard bus current ratings shall be determined by heat-rise tests in accordance with UL 67.
6. All current carrying parts shall be insulated from ground and phase to phase by high dielectric strength thermoplastic or equivalent.
7. Interior trim shall be of dead front construction to shield the user from live parts.
8. Nameplates shall contain system information and catalog number or factory order number. Interior wiring diagram, neutral wiring diagram, UL Listed label, and short circuit current rating shall be displayed on the interior.

B. Main Circuit Breaker

1. Main circuit breaker shall have an overcenter, trip-free, toggle mechanism which will provide quick-make, quick-break contact action. Circuit breakers shall have a permanent trip unit with thermal and magnetic trip elements in each pole. Each thermal element shall be true rms sensing and be factory calibrated to operate in a 40 degree C environment.
2. Two-pole and three-pole breakers shall have common tripping of all poles.
3. Breaker handle and faceplate shall indicate rated ampacity.
4. Circuit breaker escutcheon shall have international I/O markings, in addition to standard ON/OFF markings.

C. Branch Circuit Breakers

1. Circuit breakers shall be UL Listed with amperage ratings, interrupting ratings, and number of poles as indicated on the panelboard schedules.
2. Molded case branch circuit breakers shall have bolt-on type bus connectors.
3. Circuit breakers shall have an overcenter toggle mechanism which will provide quick-make, quick-break contact action. Circuit breakers shall have thermal and magnetic trip elements in each pole. Two-pole circuit breakers shall have common tripping of all poles.
4. There shall be two (2) forms of visible trip indication. The breaker handle shall reside in a position between ON and OFF. In addition, there shall be a red indicator appearing in the

clear window of a circuit breaker housing.

- D. The panelboard will be installed in an MCC section as shown on the Drawings

PART 3 EXECUTION

3.01 GENERAL

- A. The MCCs shall be located as shown on the Drawings.
- B. The Contractor shall supply factory authorized startup of all VFDs.
- C. The MCC shall be installed on a 4 inch housekeeping pad in the electrical room. Route circuits as shown on the Drawings.

3.02 QUALITY CONTROL

- A. The entire MCC shall go through a quality inspection per the manufacturer's ISO 9001 test sequence. A copy of this test sequence shall be provided for approval two (2) weeks prior to testing and shipment.

END OF SECTION 540 – MOTOR CONTROL CENTER

THIS PAGE LEFT BLANK INTENTIONALLY

SECTION 550 – TELEMETRY AND INSTRUMENTATION

PART 1 GENERAL

1.01 SCOPE OF WORK

- A. Furnish and install telemetry equipment for control and monitoring of water and wastewater systems utilizing instrumentation equipment defined herein.
- B. Coordinate the installation, field testing, and commissioning of telemetry improvements with the City of Van Buren Municipal Utilities (VBMU), including electrical improvements and any start up involving motor control centers or other controllers.

1.02 RELATED SECTIONS

- A. Section 510 – Electrical Improvements
- B. Section 540 – Motor Control Center

1.03 SUBMITTALS

- A. Submit in accordance with project requirements.

PART 2 PRODUCTS

2.01 REMOTE TELEMETRY UNIT (RTU)

- A. The RTU shall be supplied by VBMU's Telemetry provider, Micro-Comm Inc. of Olathe Kansas. The RTU shall be one (1) of the PLC based product offerings from Micro-Comm, based on the I/O requirements of the installation. The RTU shall provide all pump control, local status, and remote monitoring capabilities as dictated in the project specs. The telemetry services shall include all local control programming and remote monitor programming required.
- B. Each RTU installation shall be coordinated with the radio path from VBMU's primary repeater. Antenna towers shall be provided as required to ensure a reliable communication path.
- C. Each RTU installation shall include all accessories required for a complete installation.

2.02 SUBMERSIBLE PRESSURE TRANSMITTER

- A. The pressure transmitter shall be the primary method of sensing potable water level for VBMU's projects and shall be Micro-Comm Automation L5A or approved equal.
- B. The submersible pressure transmitter measures the height of liquid above the position of the transmitter in the tank referenced to atmospheric pressure.
- C. The submersible pressure transmitter must incorporate lightning and surge protection utilizing dual arrestor technology, grounded to case, eliminating both power supply surges and lightning ground strike, and must be UL approved intrinsically safe for use in hazardous locations when used with proper barrier.

- D. The transmitter must include a 270-pound tensile strength shielded and vented cable. Ventilation tube in the cable automatically compensates for changes in atmospheric pressure above the tank. The vent is protected with a maintenance free filter eliminating particulate or water droplets from entering the transducer.

2.03 ULTRASONIC LEVEL SENSOR

- A. For wastewater level sensing applications, water level shall be measured with an ultrasonic level system that is similar and equal to Pulsar Process Measurement Ultra 3.
- B. The ultrasonic controller shall be of wall mount design, NEMA4X, suitable for outdoor mounting or mounting inside an enclosure.
- C. The controllers shall have one (1) 4-20mA output programmed from 0 to 100% of the wet well level.
- D. The controllers shall have a minimum of three (3) SPDT alarm/control relays.
- E. The ultrasonic transducers must be compatible with the selected controller and meeting the physical measurement requirements of the project.

END OF SECTION 550 – TELEMETRY AND INSTRUMENTATION

STANDARD DETAILS

City of Van Buren Municipal Utilities

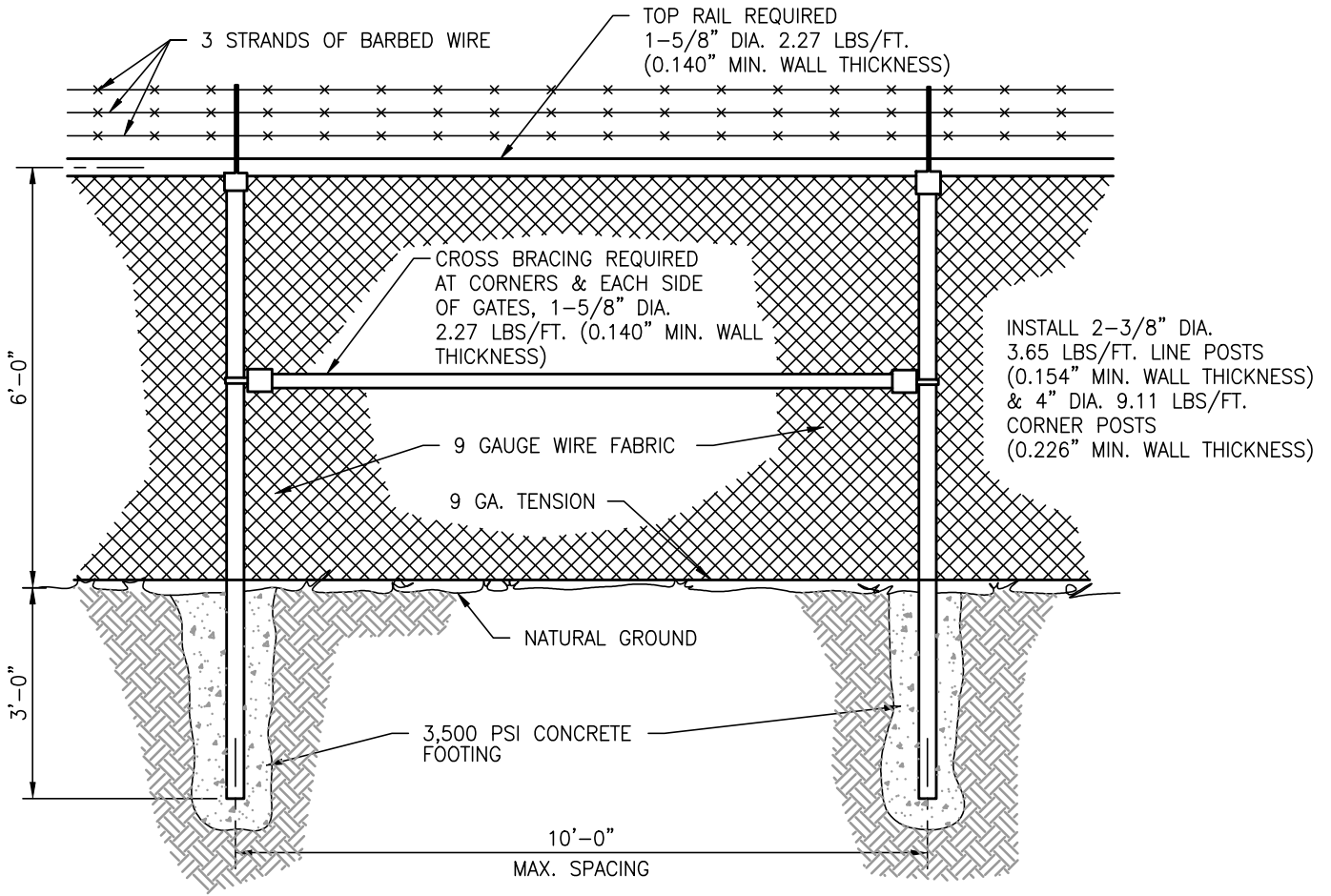

VUB MUNICIPAL UTILITIES

2806 Bryan Road • Van Buren, Arkansas
(479) 474-5067

Chain Link Security Fence

Filename: M01 FENCING-CHAIN LINK SECURITY.DWG

May 2014

Sheet:

M01

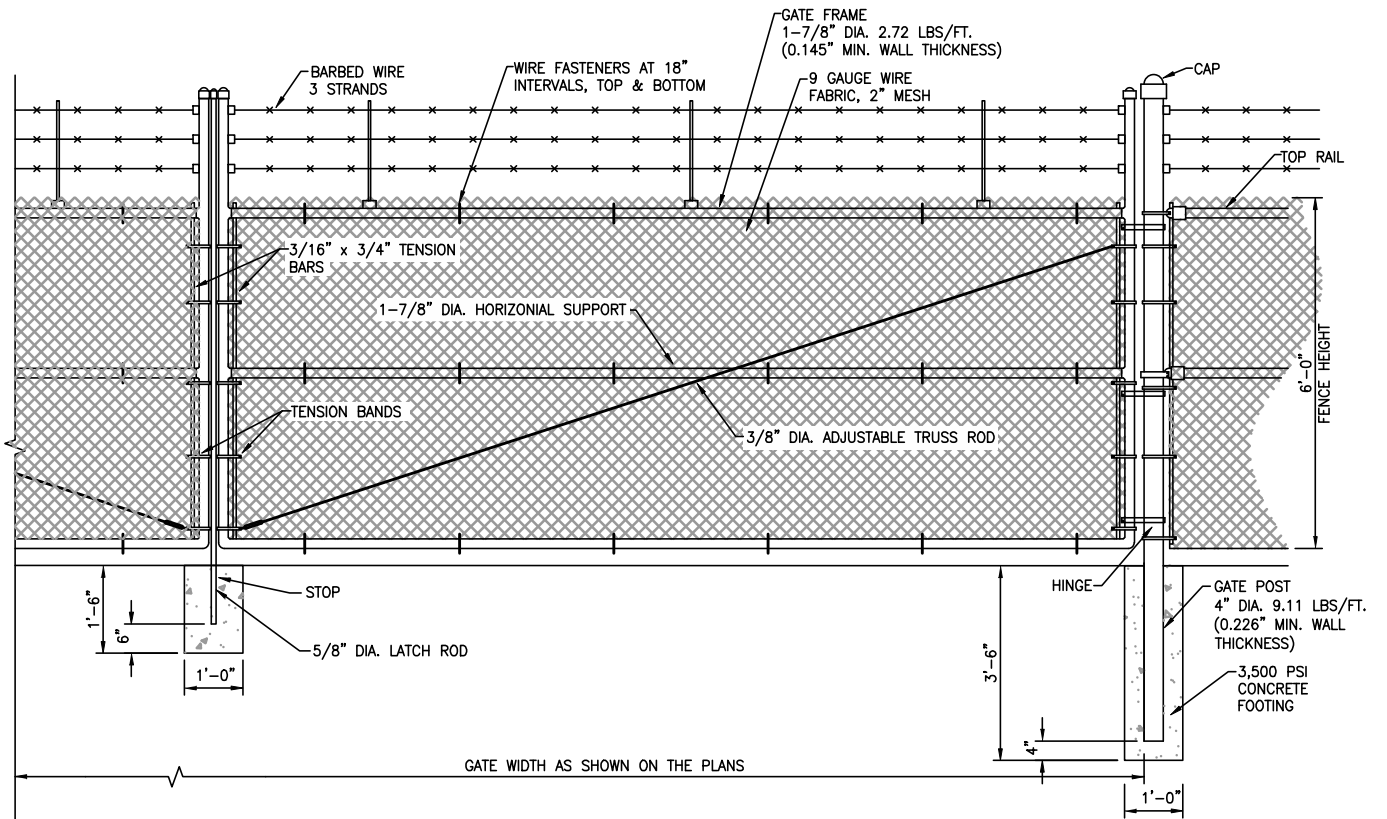

VUB MUNICIPAL UTILITIES

2806 Bryan Road • Van Buren, Arkansas
(479) 474-5067

Chain Link Fence Gate

Filename: M02_FENCING-GATE.DWG

May 2014

Sheet:

M02

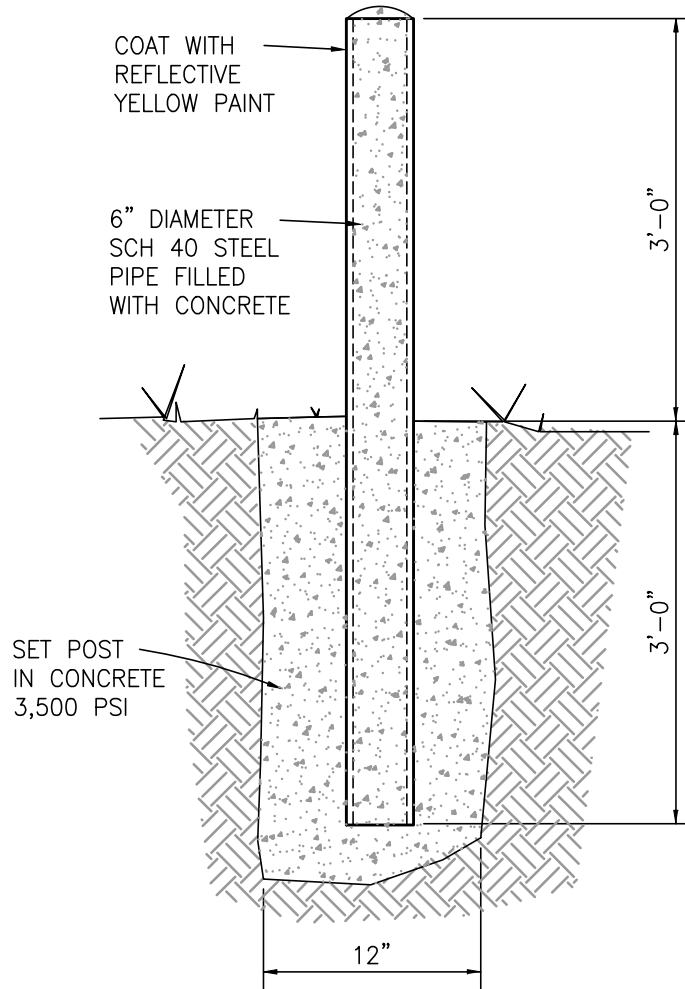

VB MUNICIPAL UTILITIES

2806 Bryan Road • Van Buren, Arkansas
(479) 474-5067

Bollard

Filename: M03 BOLLARD.DWG

May 2014

Sheet:

M03

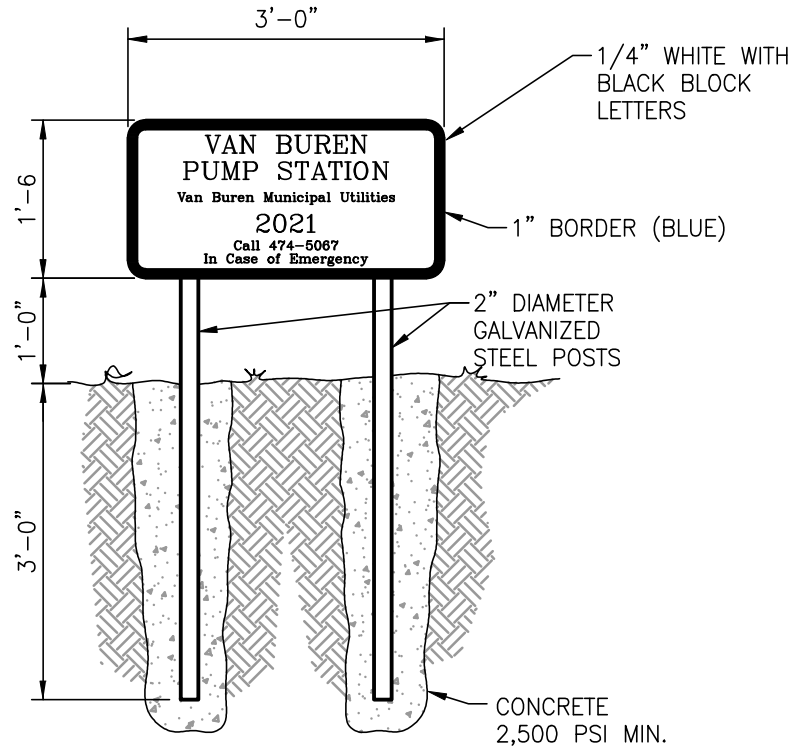

VB MUNICIPAL UTILITIES

2806 Bryan Road • Van Buren, Arkansas
(479) 474-5067

Facility Identification
Sign

Filename: M04 FACILITY ID SIGN.DWG

May 2014

Jan 2022

Sheet:

M04

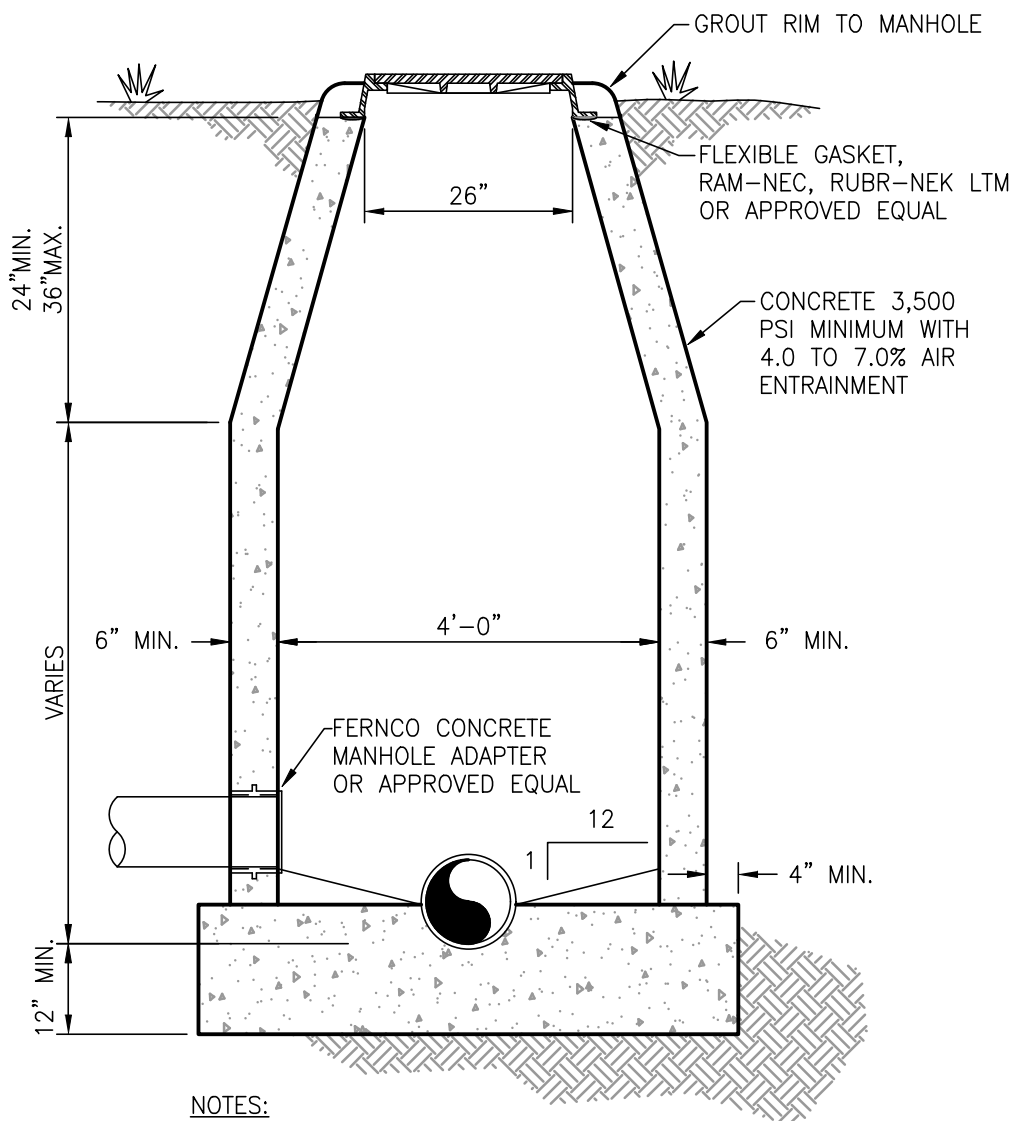

NOTES:

1. MANHOLES ARE TO BE CAST IN PLACE OR PRECAST WHERE APPROVED.
2. WATERSTOPS MUST BE USED WITH ALL TYPES OF PIPE AT MANHOLE CONNECTIONS.
3. MANHOLE RING AND COVER TO BE SIMILAR AND EQUAL TO EAST JORDAN IRON WORKS NO. 1348A/1348Z ASSEMBLY. COVER TO BE LETTERED "SANITARY SEWER".
4. WALL THICKNESS SHALL BE 8" MINIMUM FOR MANHOLES 12 FEET AND DEEPER.

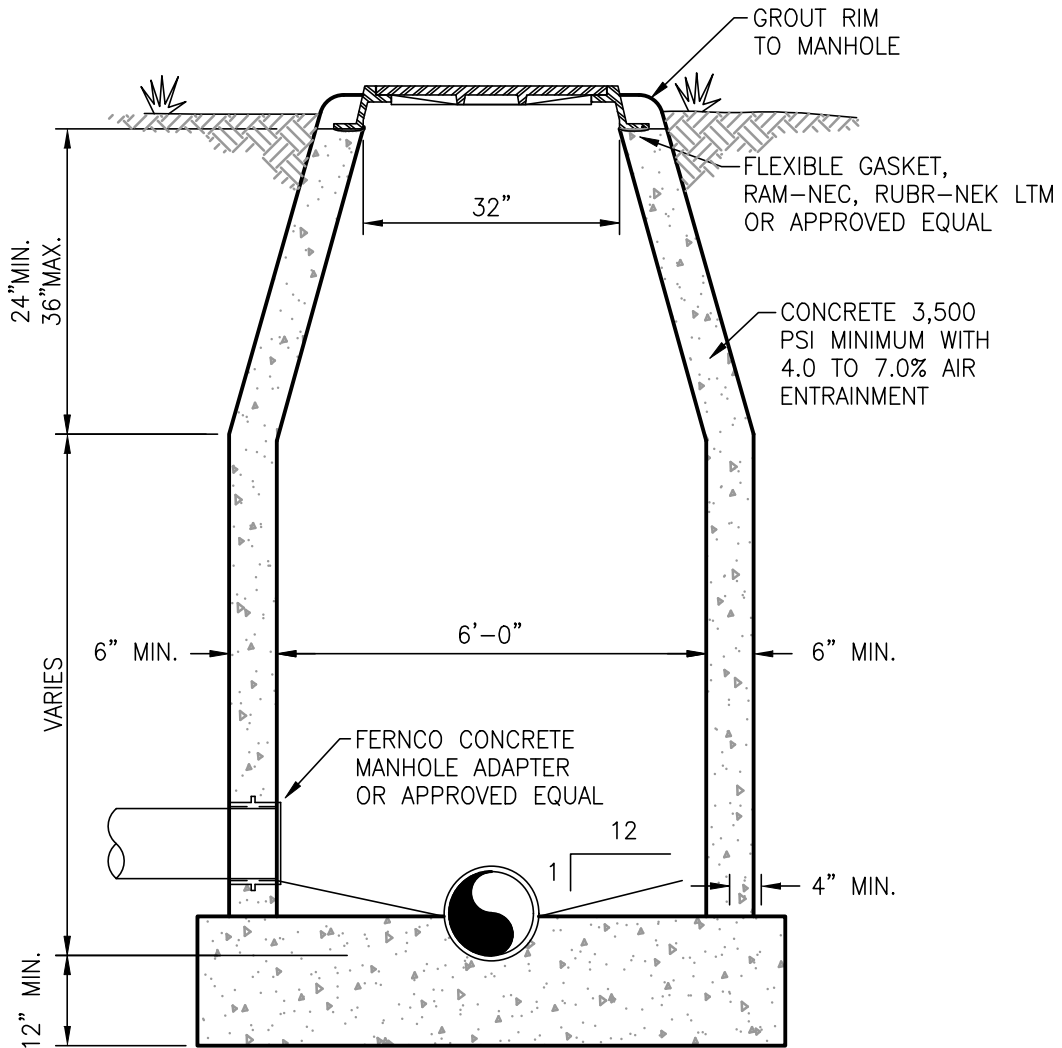

NOTES:

1. MANHOLES ARE TO BE CAST IN PLACE OR PRECAST WHERE APPROVED.
2. WATERSTOPS MUST BE USED WITH ALL TYPES OF PIPE AT MANHOLE CONNECTIONS.
3. MANHOLE RING AND COVER TO BE SIMILAR AND EQUAL TO EAST JORDAN IRON WORKS NO. 1322A/1322Z ASSEMBLY. COVER TO BE LETTERED "SANITARY SEWER".
4. WALL THICKNESS SHALL BE 8" MINIMUM FOR MANHOLES 12 FEET AND DEEPER.

VUB MUNICIPAL UTILITIES

2806 Bryan Road • Van Buren, Arkansas
(479) 474-5067

**6-Ft. Diameter
Cast-In-Place Manhole**

Filename: S02 MANHOLE 6FT.DWG

May 2014

Sheet:

S02

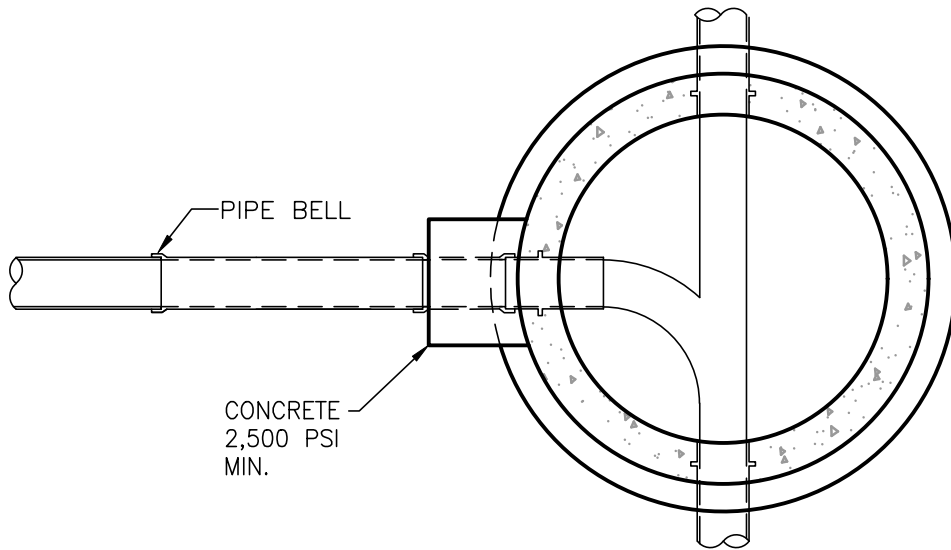

SECTION "A-A"

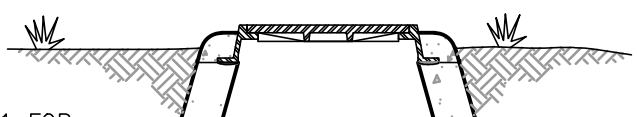

SEE DETAIL S01 FOR MANHOLE DETAILS

NOTES:

1. MANHOLES ARE TO BE CAST IN PLACE OR PRECAST WHERE APPROVED.
2. WATERSTOPS MUST BE USED WITH ALL TYPES OF PIPE AT MANHOLE CONNECTIONS.

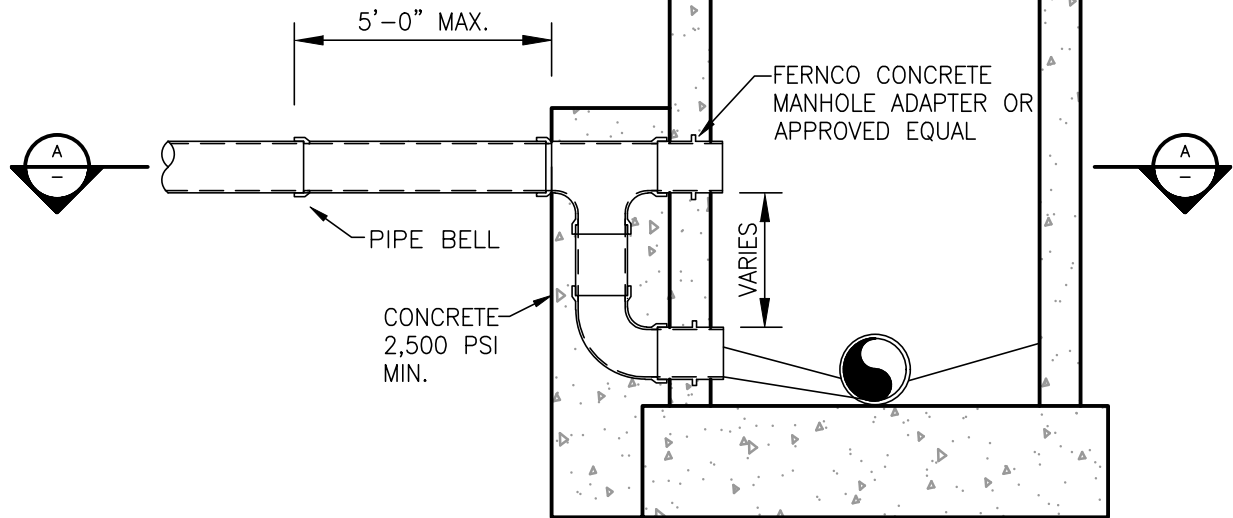

VUB MUNICIPAL UTILITIES
 2806 Bryan Road • Van Buren, Arkansas
 (479) 474-5067

Manhole Drop

Filename: S03 MANHOLE-DROP.DWG

May 2014

Sheet:
S03

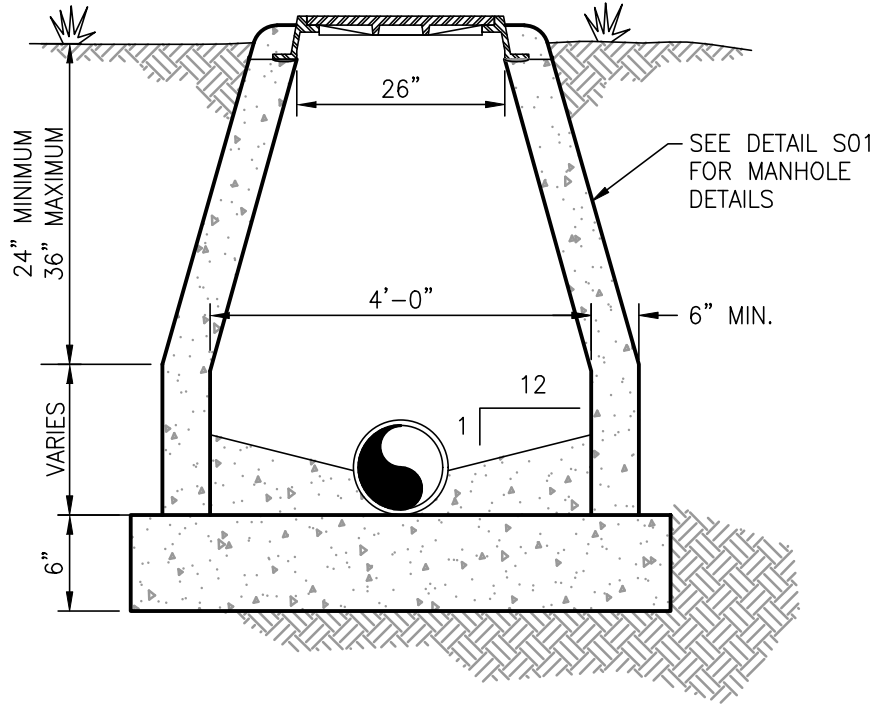

NOTES:

1. MANHOLES ARE TO BE CAST IN PLACE OR PRECAST WHERE APPROVED.
2. WATERSTOPS MUST BE USED WITH ALL TYPES OF PIPE AT MANHOLE CONNECTIONS.
3. MANHOLE RING AND COVER TO BE SIMILAR AND EQUAL TO EAST JORDAN IRON WORKS NO. 1348A/1348Z ASSEMBLY. COVER TO BE LETTERED "SANITARY SEWER".

May 2014

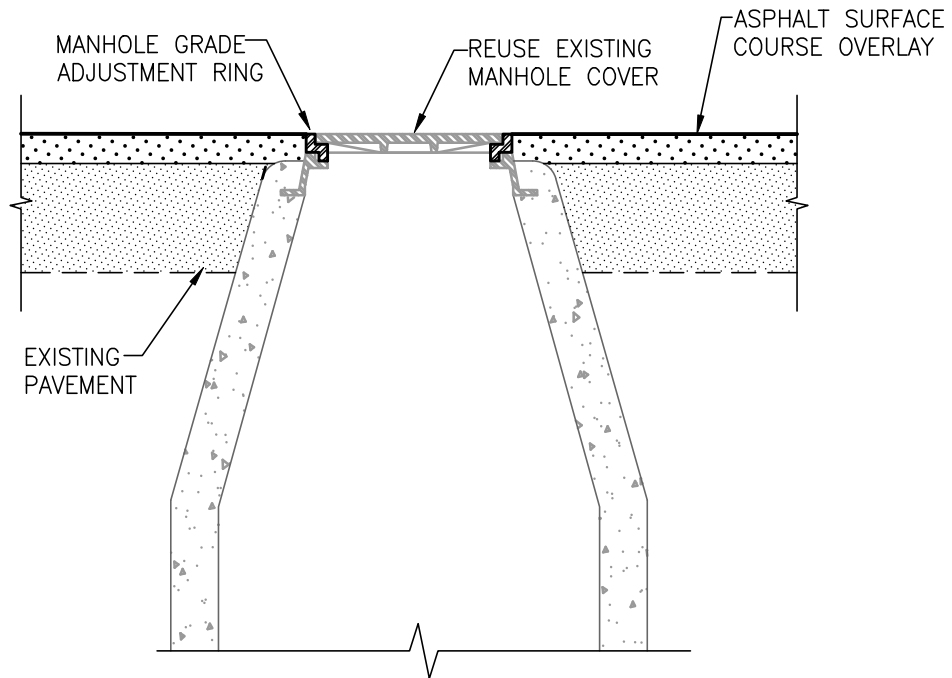

V B MUNICIPAL UTILITIES

2806 Bryan Road • Van Buren, Arkansas
(479) 474-5067

Manhole Grade Adjustment

Filename: S05 MANHOLE GRADE ADJUST.DWG

May 2014

Sheet:

S05

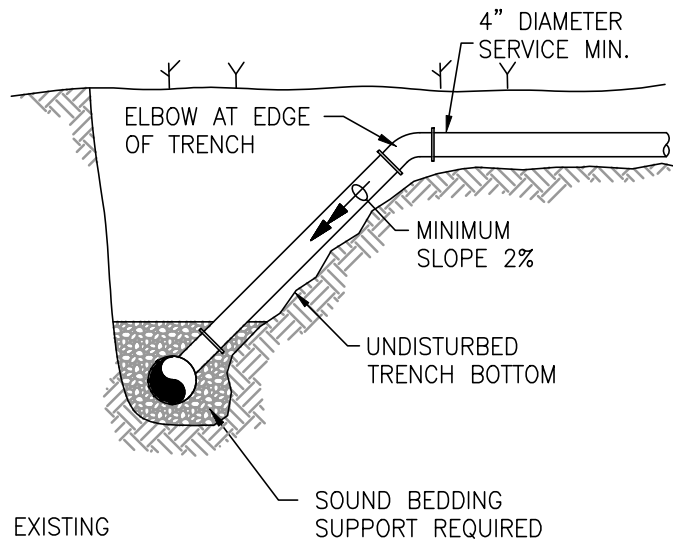

FOR CONNECTION TO EXISTING
SEWER MAIN USE ROMAC
WIDE RANGE SEWER SADDLE
MODEL NO. 218-4804U OR
APPROVED EQUAL

VB MUNICIPAL
UTILITIES

2806 Bryan Road • Van Buren, Arkansas
(479) 474-5067

Sewer Service
Lateral Connection

Filename: S06 LATERAL CONNECTION.DWG

May 2014

Jan 2022

Sheet:

S06

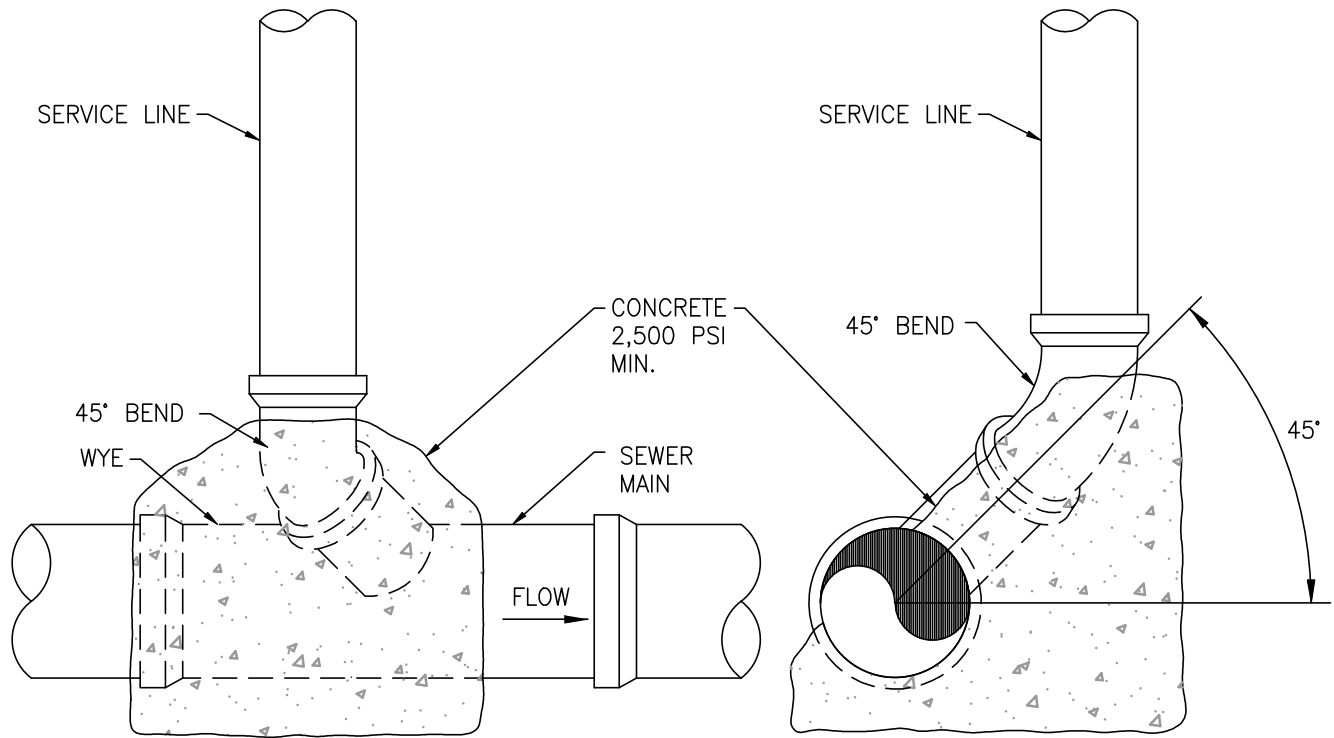

NOTE:

1. CONCRETE BLOCKING SHALL BE INSTALLED WHERE VERTICAL DROP IN THE SERVICE LINE EXCEEDS 5 FEET.

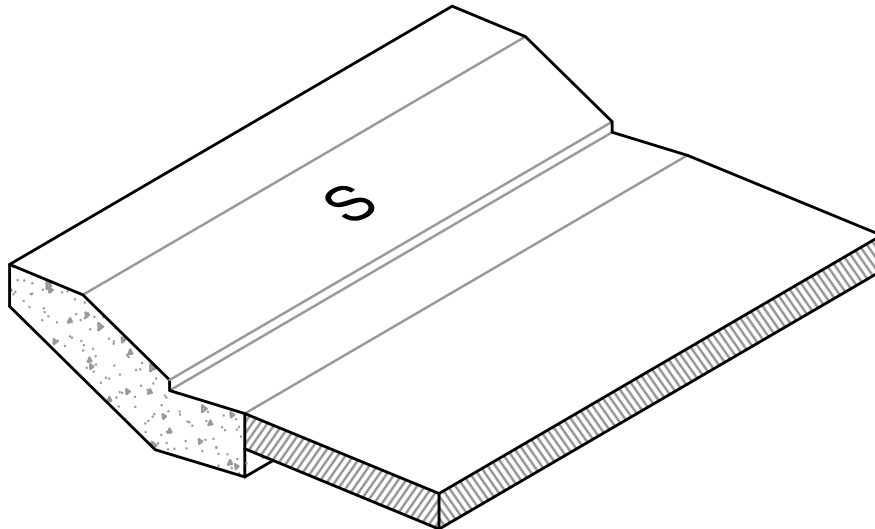

DRIVE OVER CURB

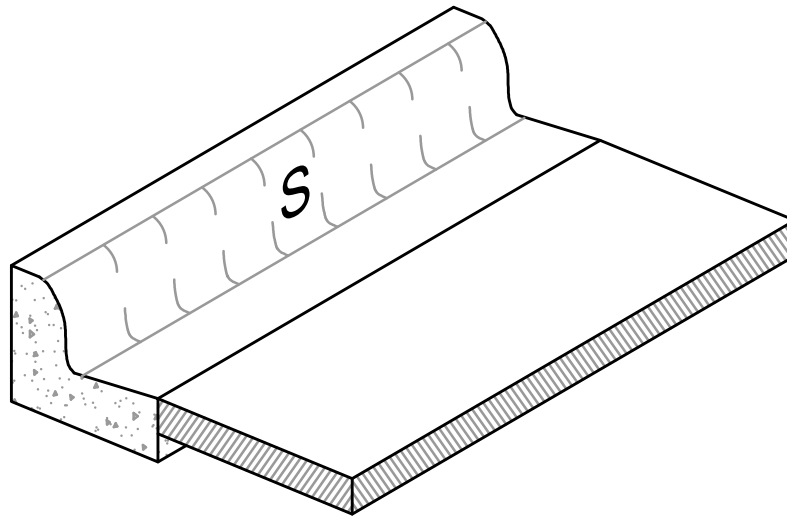

VERTICAL CURB

NOTES:

1. ALL WATER SERVICE AND SANITARY SEWER SERVICE LINE LOCATIONS SHALL BE APPROXIMATELY MARKED AS FOLLOWS WHERE THE SERVICE LINE CROSSES THE CURB:

WATER SERVICE "W" AT FACE OF CURB
SEWER SERVICE "S" AT FACE OF CURB

2. LETTERS SHALL BE A MINIMUM OF 3" TALL AND 1/4 INCH DEEP
3. LETTER SHALL BE EITHER DIE STAMPED OR ENGRAVED. HAND WRITTEN LETTERS WILL NOT BE ACCEPTED.

NOTES:

1. ALL PAVEMENT CUTS FOR UTILITY TRENCHING IN PUBLIC STREETS AND ALLEYS SHALL BE REPAIRED IN ACCORDANCE WITH THE VAN BUREN STREET CUT STANDARDS, LATEST EDITION.
2. FLOWABLE FILL (UTILITY MIX BACKFILL) FOR TRENCHES SHALL BE PROTECTED WITH BRIDGE PLATES OR A TEMPORARY SURFACE SEAL OF COLD MIX ASPHALT CONCRETE UNTIL THE FINAL PAVEMENT REPAIR IS INSTALLED. COLD MIX ASPHALT CONCRETE IS NOT ACCEPTABLE FOR FINAL REPAIR.
3. FLOWABLE FILL SHALL BE ALLOWED TO CURE FOR A PERIOD OF NOT LESS THAN 24 HOURS PRIOR TO PLACEMENT OF SURFACE. FLOWABLE FILL SHALL BE PROTECTED FROM FREEZING OR TOO RAPID CURING.
4. FLOWABLE FILL SHALL BE INSTALLED TO NEAT LINES AND SHALL NOT EXCEED THE MAXIMUM TRENCH WIDTH AS INDICATED ON THE TRENCHING DETAILS.
5. UNLESS OTHERWISE INDICATED ON THE PLANS, PC CONCRETE SURFACE REPAIR SHALL BE PORTLAND CEMENT CONCRETE WITH MINIMUM 28 DAY COMPRESSIVE STRENGTH OF 3,500 PSI, 6% ENTRAINED AIR, AND ENGINEERED FIBER REINFORCEMENT. CONCRETE REPAIR SURFACE SHALL BE FINISHED WITH A ROUGH BROOMED TEXTURE, OR MATCHING EXISTING ADJACENT SURFACES.
6. CONCRETE PAVEMENT REPAIRS SHALL NOT BE OPENED TO TRAFFIC FOR A PERIOD OF NOT LESS THAN 72 HOURS FOLLOWING PLACEMENT. BRIDGE PLATES SHALL BE USED TO PROTECT FINISHED CONCRETE ON ANY LANES REQUIRED TO BE OPENED.
7. WHEN ON-SITE BACKFILL IS APPROVED BY THE ENGINEER, IT SHALL BE FREE OF ROCKS, CLOUDS OR FROZEN MASSES OVER 3 INCHES IN DIAMETER OR ANY ORGANIC MATTER.
8. BEDDING, BACKFILL AND COMPACTION WITH ON-SITE MATERIALS IS CONSIDERED INCIDENTAL TO THE PIPE OR STRUCTURE INSTALLATION.
9. GRANULAR BACKFILL AND BEDDING SHALL BE 3/4 INCH MAX. TO NO. 4 MATERIAL IN ACCORDANCE WITH THE SPECIFICATIONS.
10. FLOWABLE FILL SHALL BE A PLANT MIXED SLURRY OF SAND, CEMENT AND FLYASH WITH A 28 DAY COMPRESSIVE STRENGTH OF 300 PSI IN ACCORDANCE WITH THE SPECIFICATIONS.
11. IF PIPE OR INLETS ARE LOCATED UNDER OR ADJACENT TO SIDEWALKS, FLOWABLE FILL OR COMPACTED GRANULAR BACKFILL SHALL BE USED FOR BACKFILL TO WITHIN 2 FEET OF FINISHED GRADE.
12. FOR DEEP TRENCHES, DEPTH OF FLOWABLE FILL SHALL BE A MAXIMUM OF 4 FEET DEEP, AS MEASURED DOWN FROM THE FINISHED SUBGRADE, UNLESS OTHERWISE DIRECTED BY THE ENGINEER. GRANULAR BACKFILL MATERIAL SHALL BE USED FROM BOTTOM OF FLOWABLE FILL TO THE TOP OF PIPE ZONE.
13. SURFACE PATCH AND DEEP PATCH SHALL EXTEND A MINIMUM OF 12 INCHES BEYOND THE OUTSIDE EDGE OF TRENCH EXCAVATION. FOR CONCRETE PAVEMENT AND APRONS, REPAIRS WITHIN 5 FEET OF AN EXISTING JOINT SHALL BE REMOVED AND REPLACED TO THE EXISTING JOINT. FOR ALL ASPHALT STREETS, IF THE SAWCUT IS WITHIN 3 FEET OF THE EDGE OF THE EXISTING ASPHALT SURFACE OR OTHER PATCH, THE EXISTING ASPHALT SHALL BE REMOVED TO THAT EDGE AND THE ENTIRE SECTION REPLACED. LONGITUDINAL SAWCUTS SHALL NOT FALL WITHIN 12 INCHES OF THE TIRE PATH.

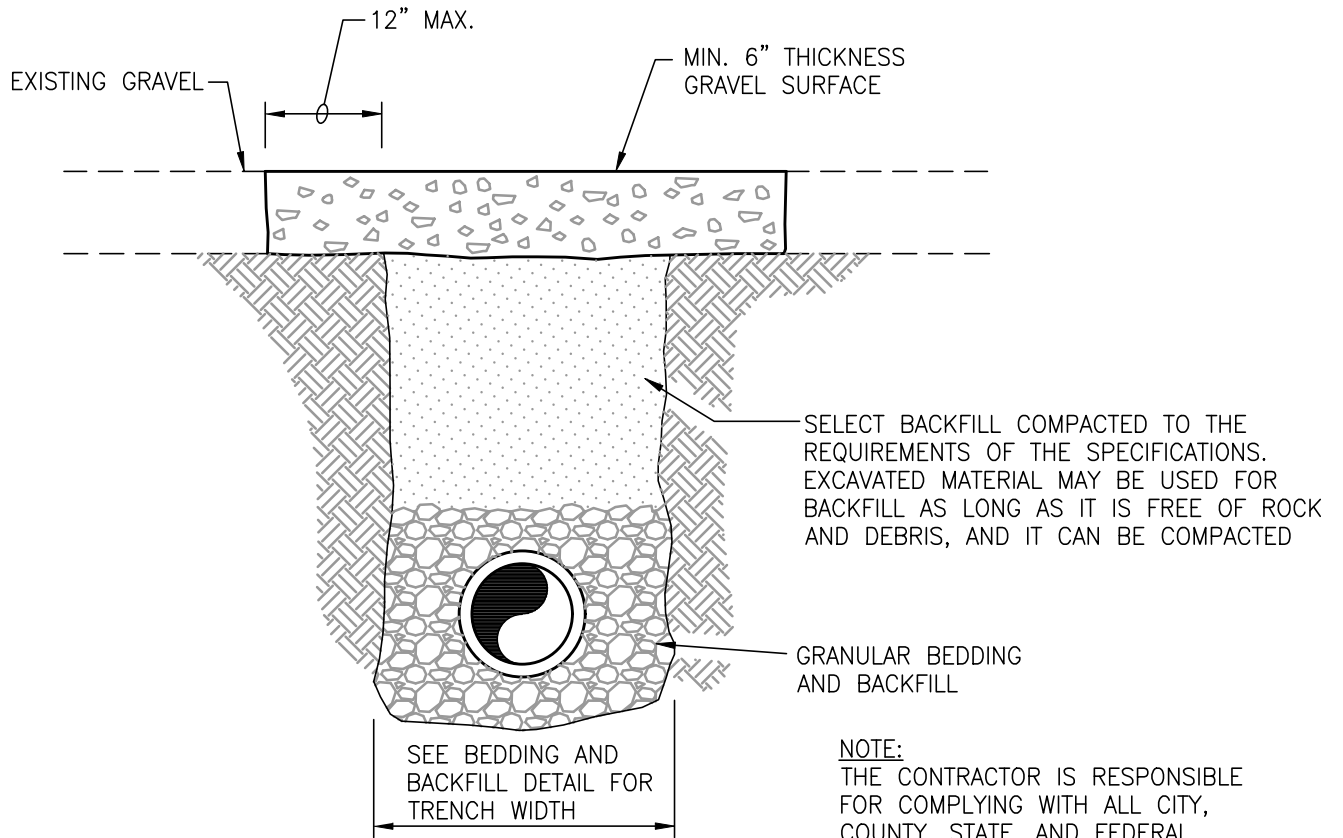

NOTE:
 THE CONTRACTOR IS RESPONSIBLE FOR COMPLYING WITH ALL CITY, COUNTY, STATE, AND FEDERAL REGULATIONS AND REQUIREMENTS FOR THE REPAIR OR REPLACEMENT OF PAVEMENTS.

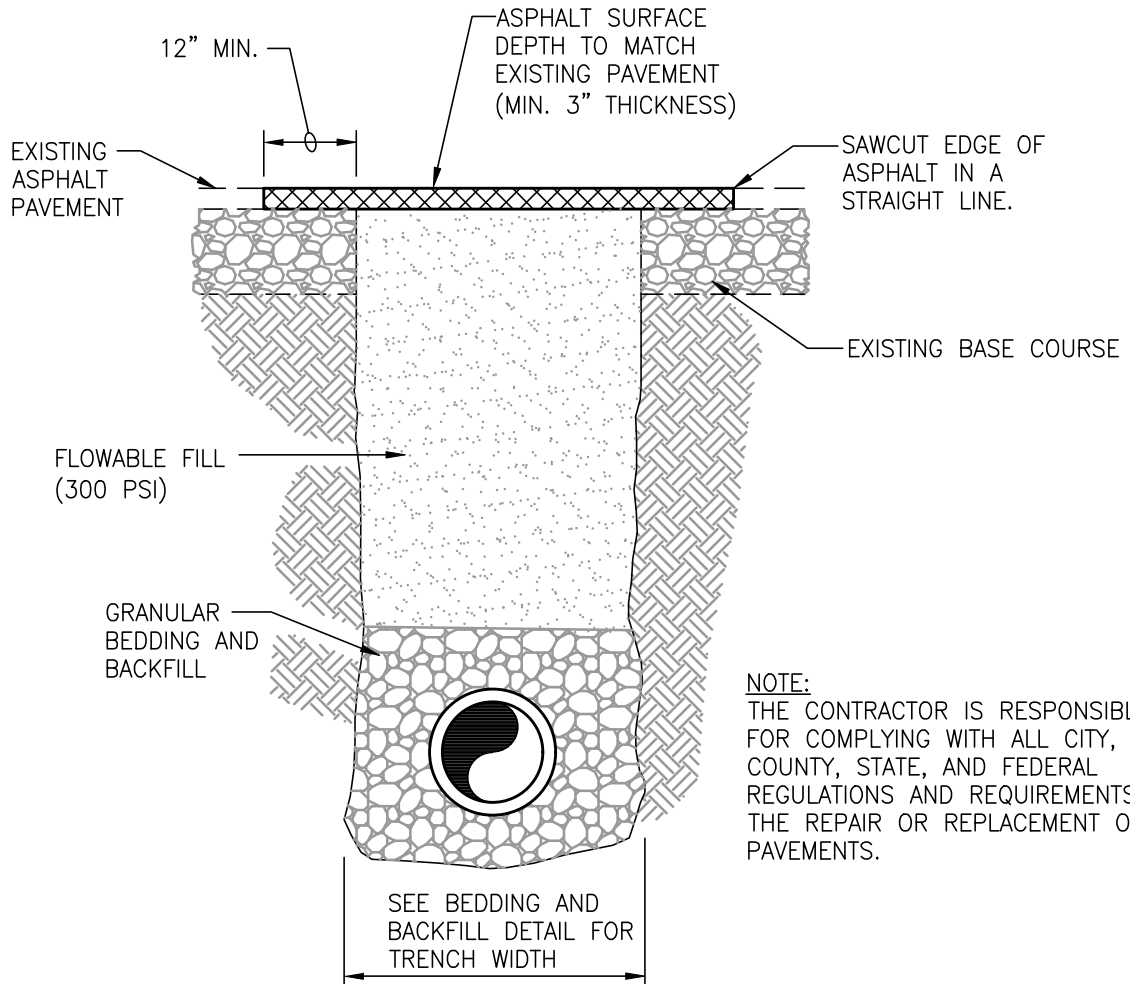

NOTE:
 THE CONTRACTOR IS RESPONSIBLE FOR COMPLYING WITH ALL CITY, COUNTY, STATE, AND FEDERAL REGULATIONS AND REQUIREMENTS FOR THE REPAIR OR REPLACEMENT OF PAVEMENTS.

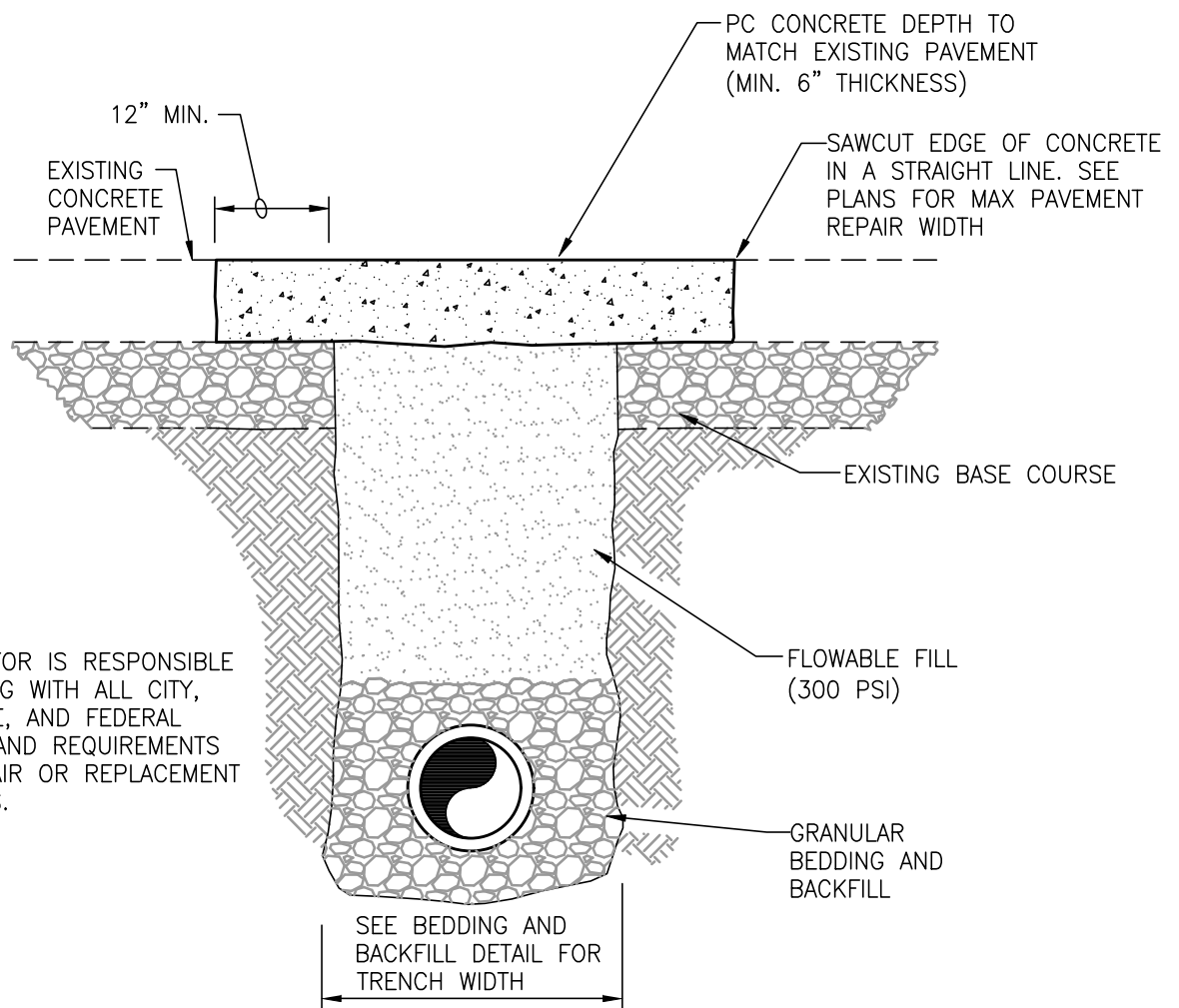

NOTE:
 THE CONTRACTOR IS RESPONSIBLE FOR COMPLYING WITH ALL CITY, COUNTY, STATE, AND FEDERAL REGULATIONS AND REQUIREMENTS FOR THE REPAIR OR REPLACEMENT OF PAVEMENTS.

VUB MUNICIPAL UTILITIES

2806 Bryan Road • Van Buren, Arkansas
 (479) 474-5067

Trench Backfill and Concrete Surface Repair

Filename: T04 TRENCH WITH CONCRETE REPAIR.DWG

May 2014

Jan 2022

Sheet:

T04

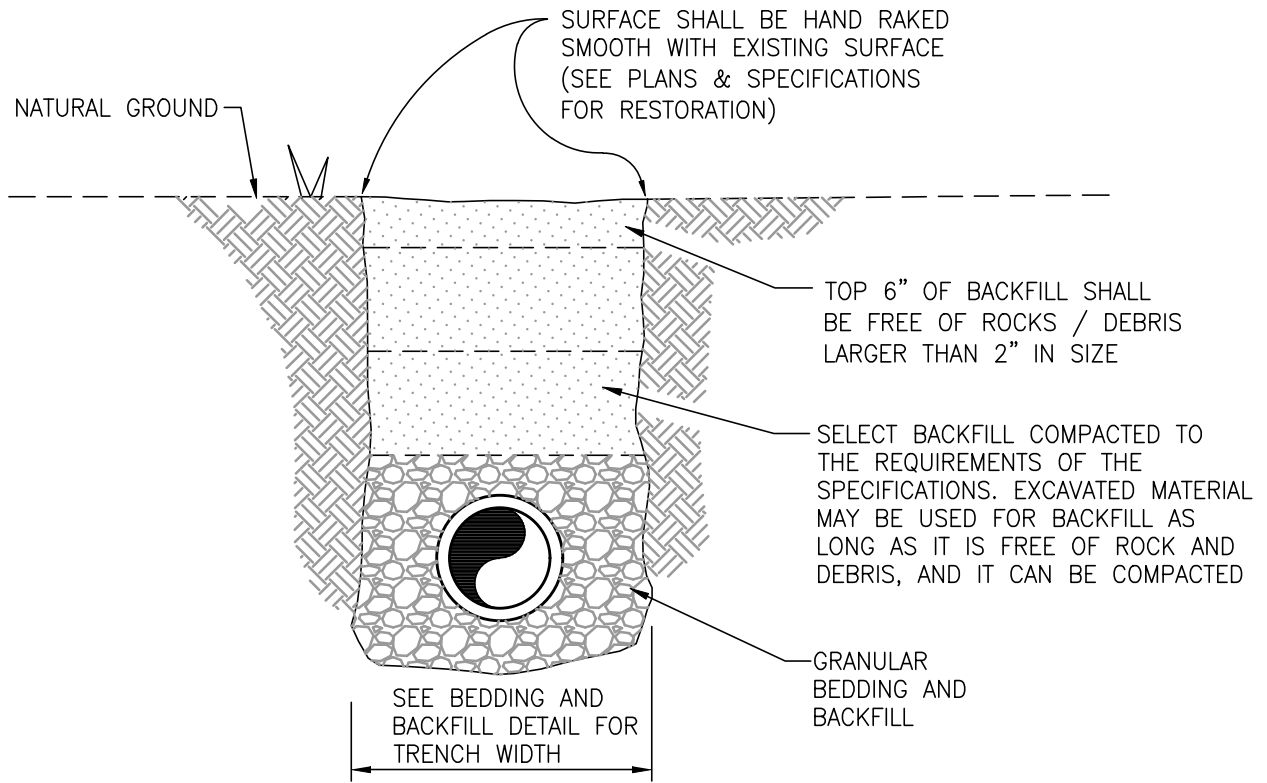

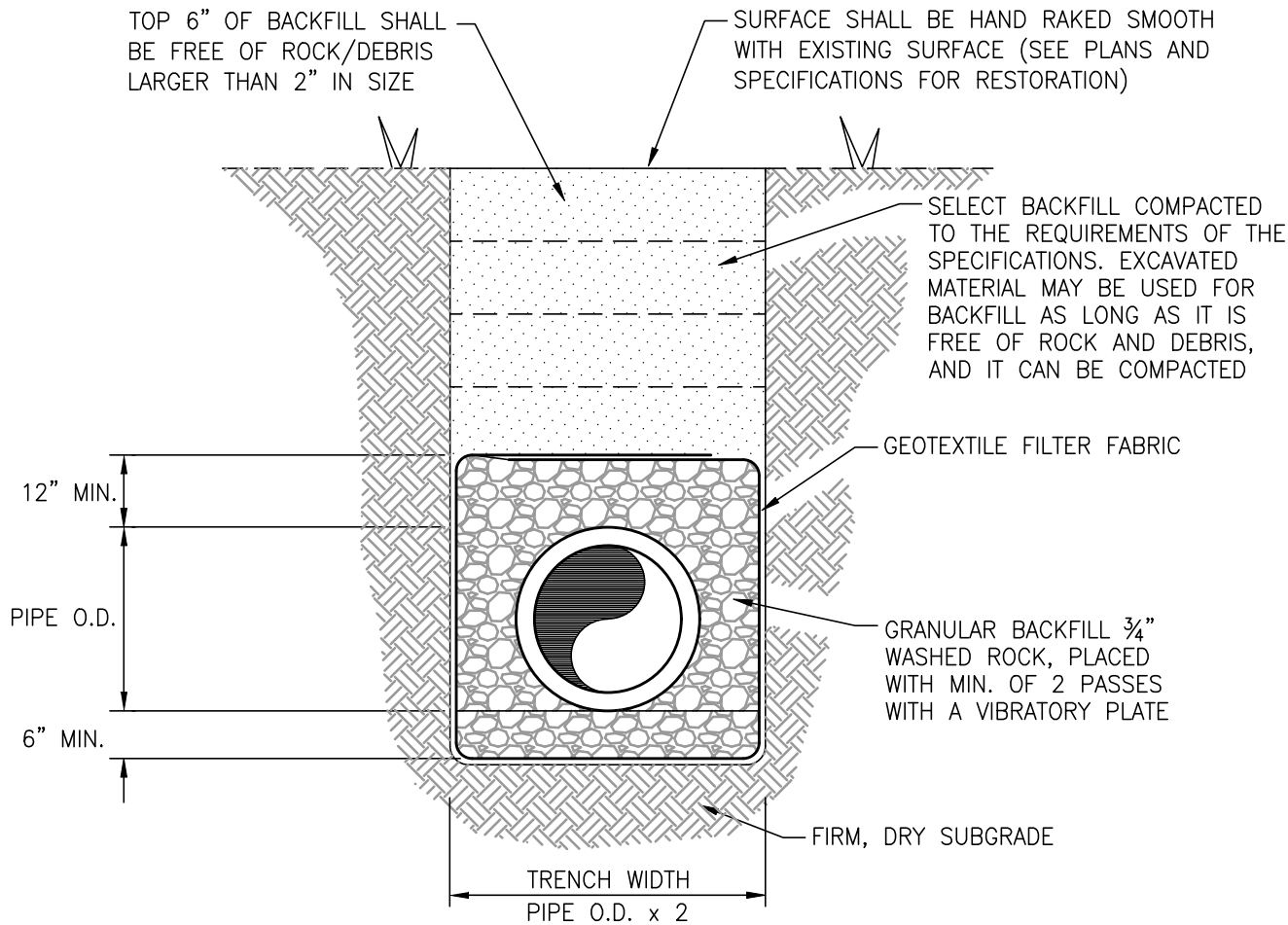

NOTES:

1. GEOTEXTILE FABRIC TO BE NON-WOVEN POLYPROPYLENE, MIRAFI 160N OR EQUAL.
2. GEOTEXTILE FABRIC TO BE CONTINUOUS AND LAPPED 24-INCHES AT ALL EDGES.

BEDDING DEPTH TABLE

WATER LINE
0.25 X PIPE I.D. (4" MIN)
SEWER LINE
6" MIN.

TRENCH WIDTH TABLE

WATER LINE
MINIMUM 18" OR OD + 12" OD + 24" MAX.
SEWER LINE
OD + 18" MIN. OD + 30" MAX.

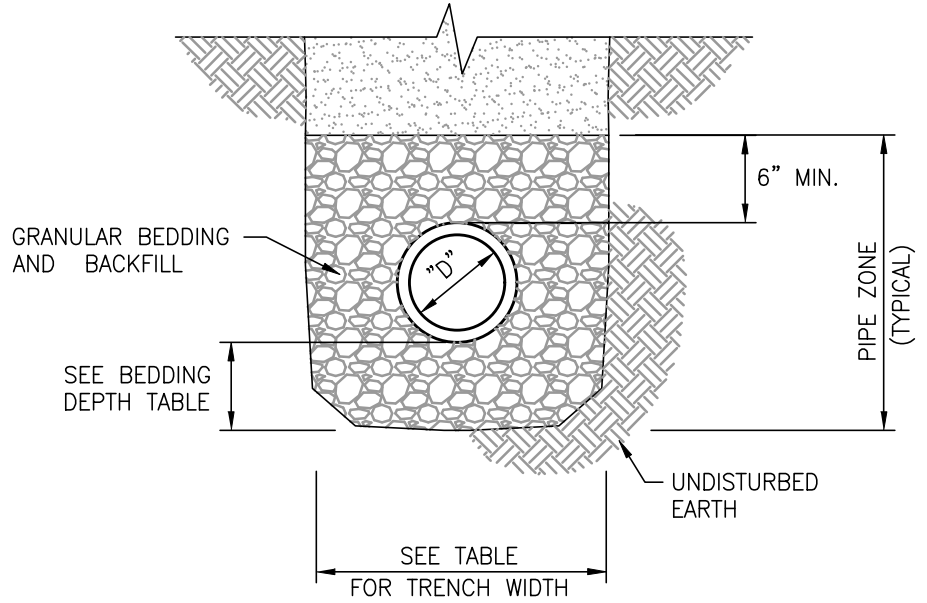

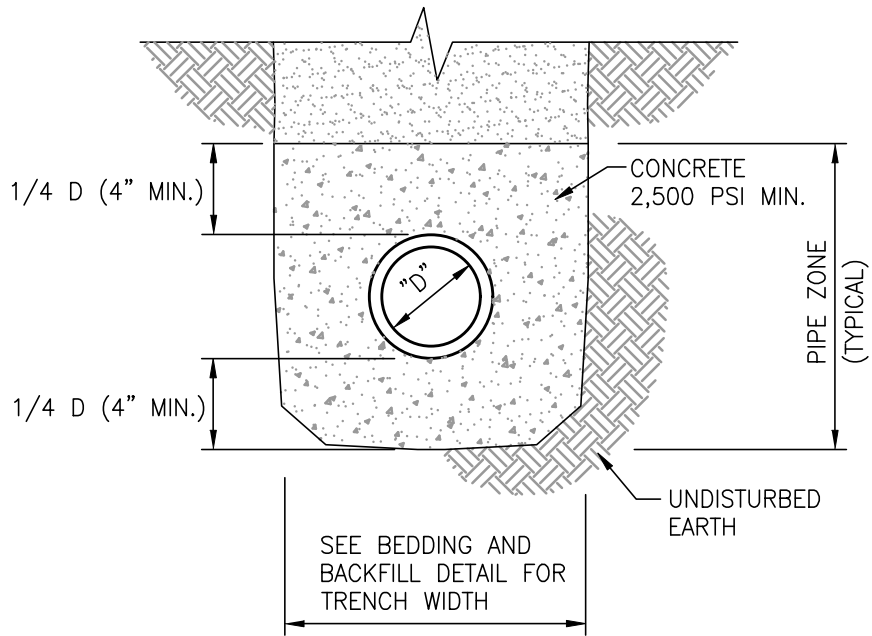

Notes:

1. CASING SHALL BE DESIGNED TO SUPPORT THE LOAD OF THE ROADWAY AND SUPERIMPOSED LOADS THEREON, AND AS A MINIMUM, SHALL EQUAL THE STRUCTURAL REQUIREMENTS FOR ROADWAY DRAINAGE FACILITIES. CASING SHALL BE COMPOSED OF MATERIALS OF SATISFACTORY DURABILITY UNDER CONDITIONS TO WHICH THEY MAY BE SUBJECTED.
2. FOR STREET CROSSINGS OR AS INDICATED ON THE PLANS, CASINGS SHALL HAVE A MINIMUM OF 3 FEET (36") OF COVER MEASURED VERTICALLY FROM THE FLOW LINE OF PARALLEL DITCHES OR 3-1/2 FEET (42") OF COVER MEASURED VERTICALLY FROM THE STREET SURFACE, WHICHEVER IS GREATER. UNLESS OTHERWISE DIRECTED BY THE STATE HIGHWAY DEPARTMENT, CASINGS SHALL HAVE A MINIMUM OF 4 FEET (48") OF COVER MEASURED VERTICALLY FROM THE FLOW LINE OF PARALLEL DITCHES OR 5 FEET (60") OF COVER MEASURED VERTICALLY FROM THE STREET SURFACE, WHICHEVER IS GREATER.
3. ALL ENCASED CROSSING OF STATE HIGHWAYS SHALL BE IN ACCORDANCE WITH THE STATE'S UTILITY ACCOMMODATION POLICY.
4. CASINGS SHOULD EXTEND THE FULL WIDTH OF THE STREET OR HIGHWAY RIGHT-OF-WAY, BUT AT A MINIMUM MUST EXTEND 6 FEET (72") BEYOND THE TOE OF THE SLOPE IN AN EMBANKMENT SECTION, THE FLOWLINE OF THE PARALLEL DITCH, OR THE BACK OF CURB FOR THE STREET OR HIGHWAY SECTION.
5. INSTALL STAINLESS STEEL BAND CASING INSULATORS, MODEL NO. 59 BY J-FOUR PIPELINE PRODUCTS OR APPROVED EQUAL. INSTALLATION SHALL BE IN ACCORDANCE WITH MANUFACTURER'S RECOMMENDATIONS.
6. SEAL EACH CASING END WITH MECHANICAL-LINKED RUBBER SEALS AND ZIPPERED END SEALS. DEPENDING ON THE SIZE OF THE CARRIER AND ENCASEMENT PIPES, THE INSTALLATION OF THE MECHANICAL-LINKED RUBBER SEALS MAY REQUIRE THE INSTALLATION OF INTERMEDIATE DUCTILE IRON SLEEVES AND A SECOND ROW OF LINKED RUBBER SEALS. THE SIZE OF THE INTERMEDIATE ROW OF LINKED RUBBER SEALS SHALL BE BASED ON MANUFACTURER'S RECOMMENDATIONS. LINKED RUBBER SEALS SHALL CONSIST OF MODULAR BOLTED SYNTHETIC RUBBER SEALING ELEMENTS SUITABLE FOR DIRECT-BURY INSTALLATIONS, AND SHALL BE LINK-SEAL BY THUNDERLINE MODULAR SEALS (PIPELINE SEAL AND INSULATOR, INC.) OR APPROVED EQUAL. ZIPPERED END SEALS SHALL BE BY J-FOUR PIPELINE PRODUCTS OR APPROVED EQUAL.



2806 Bryan Road • Van Buren, Arkansas
(479) 474-5067

Encasement Pipe Notes

Filename: T09 ENCASEMENT PIPE-NOTES.DWG

May 2014

Jan 2022

Sheet:

T09

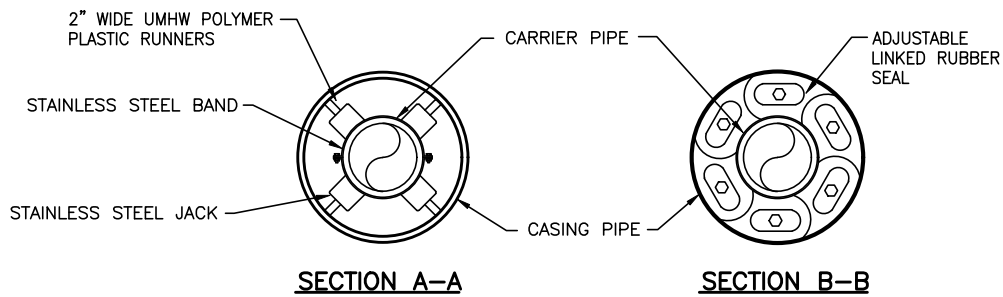
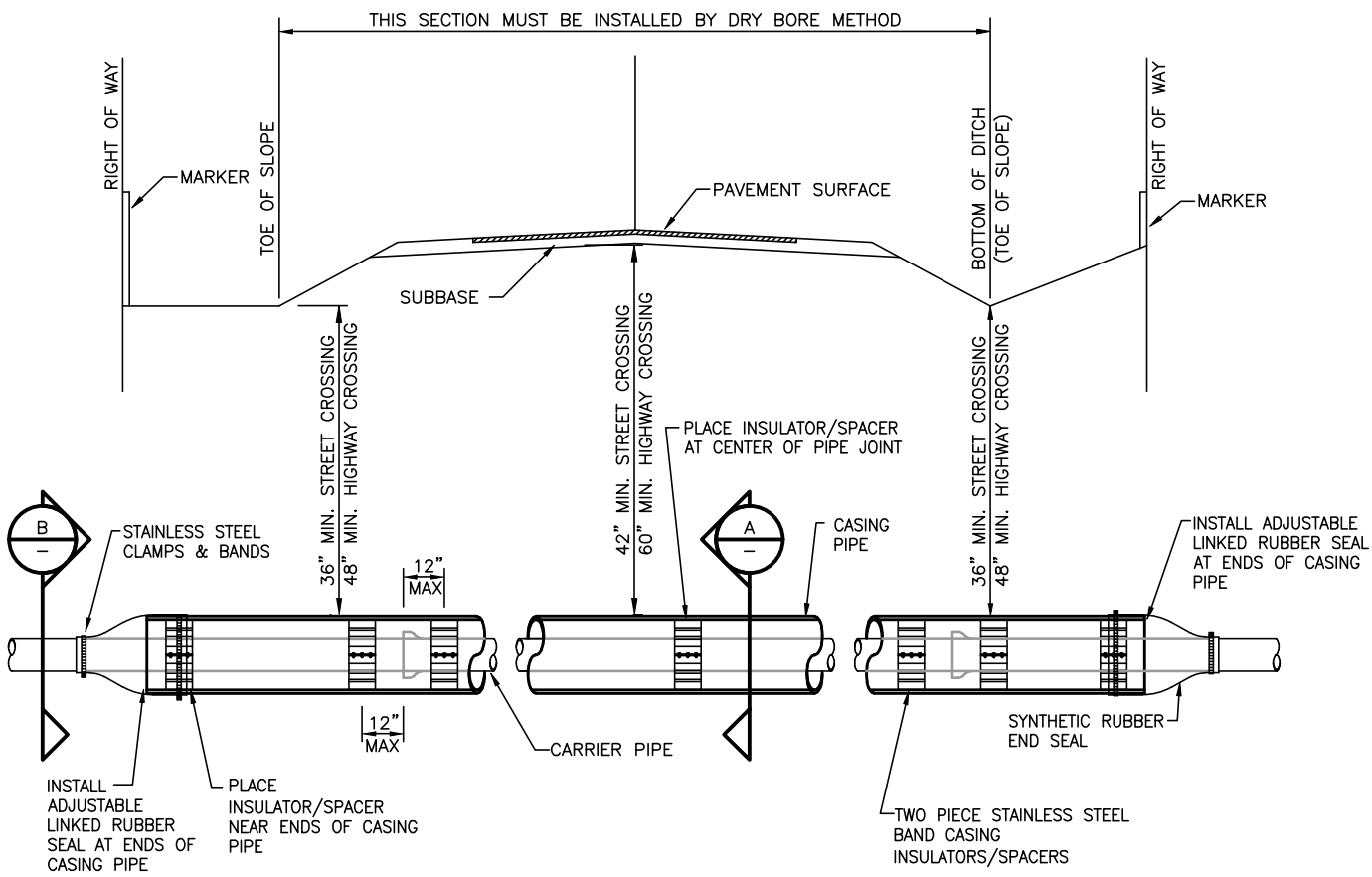

NOTES:

CARRIER & CASING SIZES											
CARRIER	4"	6"	8"	10"	12"	12"	16"	18"	20"	24"	30"
CASING	16"	16"	16"	18"	20"	24"	30"	30"	36"	36"	42"
CASING/WALL THICKNESS	.219	.219	.219	.250	.375	.438	.500	.500	.500	.500	.625

- NOTES:
1. A MIN. OF THREE SPACERS IS REQUIRED PER JOINT; SPIGOT, MIDDLE & BELL (MAX. OF 2 FT. SEPARATION OF SPACERS AT JOINT). MAX. ALLOWABLE CLEARANCE BETWEEN I.D. OF CARRIER PIPE & TOP RUNNER OF SPACER IS 1".
 2. ALL D.I. PIPE JOINTS WITHIN CASING SHALL HAVE 'FIELD LOK' GASKET BY US PIPE OR APPROVED EQUAL. EACH RESTRAINED JOINT SHALL BE IDENTIFIED WITH THE MANUFACTURER'S MARKING ON THE BELL.

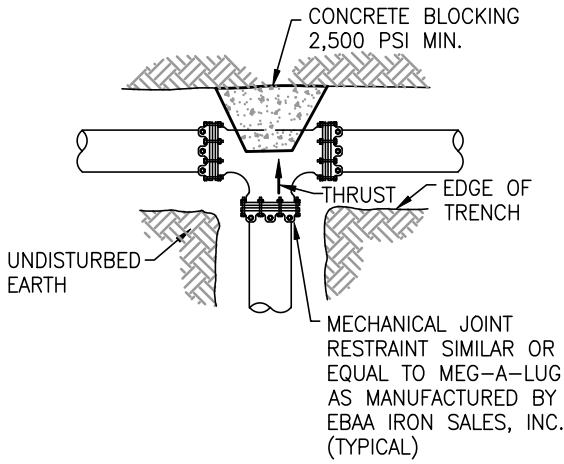

BLOCKING FOR TEES

N.T.S.

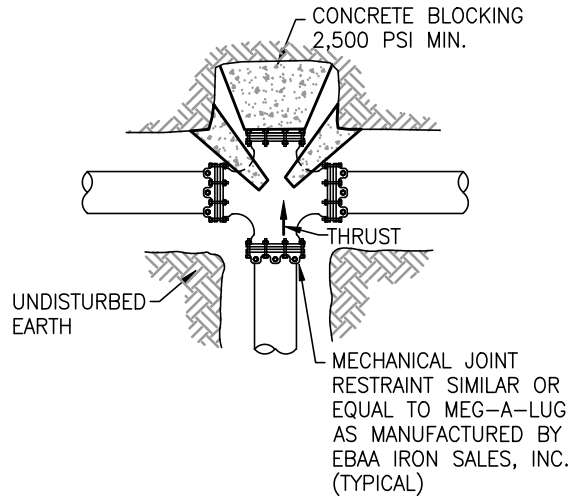

BLOCKING FOR CROSSES

N.T.S.

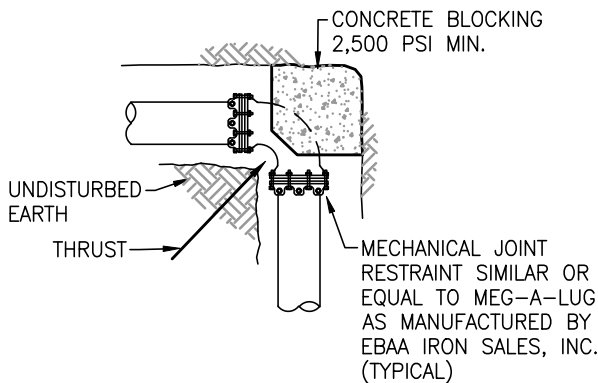

BLOCKING FOR BENDS

N.T.S.

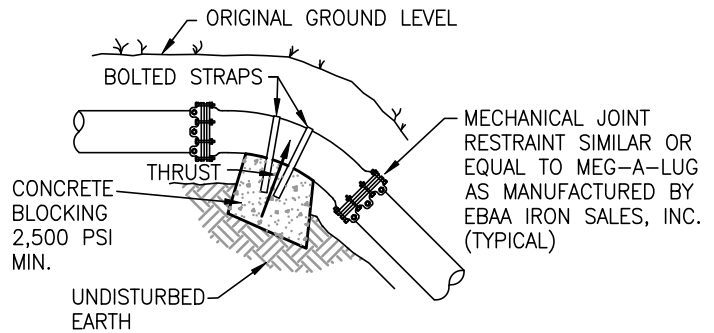

BLOCKING FOR BENDS

N.T.S.

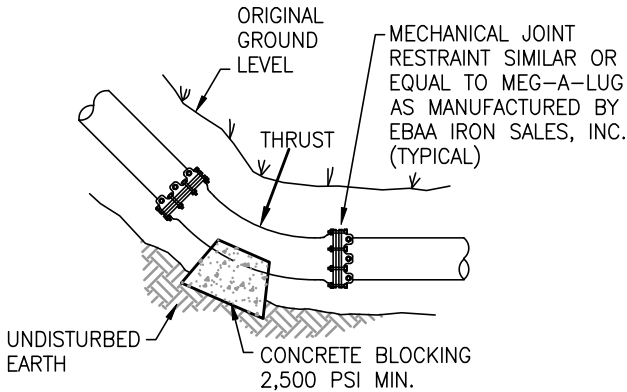

BLOCKING FOR BENDS

N.T.S.

1. THRUST BLOCKING MUST BE DESIGNED BASED ON PROJECT AND LOCATION-SPECIFIC REQUIREMENTS. IF NOT PROVIDED BY THE DESIGN ENGINEER IN THE CONSTRUCTION DRAWINGS AND/OR DETAILS, THE CONTRACTOR SHALL SUBMIT FOR REVIEW A BLOCKING DESIGN(S) FROM AN ENGINEER LICENSED IN THE STATE OF ARKANSAS. BLOCKING DESIGNS SHALL MINIMALLY TAKE INTO ACCOUNT THE FOLLOWING: PIPE LINE PRESSURE, SURGE ALLOWANCE, ALLOWABLE SOIL BEARING LIMITS, TRENCH DEPTH, AND THE REACTION BEARING AREA REQUIRED FOR THE THRUST BLOCK.
2. THE UTILITY WILL CONSIDER A PIPE JOINT RESTRAINT SYSTEM AS AN ALTERNATIVE TO CONCRETE THRUST BLOCKING. NO CONCRETE BLOCKING SHALL BE USED IF A RESTRAINED PIPE SYSTEM IS SHOWN ON THE CONSTRUCTION PLANS.
3. AN ALLOWANCE FOR WATER HAMMER (SURGE) OF 50% OF THE PRESSURE CONDITION SHALL BE USED IN SIZING THRUST BLOCKING AND RESTRAINED PIPE LENGTHS UNLESS OTHERWISE DIRECTED.
4. ALL CONCRETE THRUST BLOCKING SHALL BE CAST AGAINST AN UNDISTURBED TRENCH WALL, AND THE CONTRACTOR SHALL AVOID OVER-EXCAVATING THE TRENCH.
5. BLOCKING FOR VERTICAL DOWN BENDS SHALL NOT CONSIDER SOIL TYPE OR BEARING LIMITS AND MUST BE DESIGNED BASED ON A GRAVITY REACTION TO THE THRUST FORCE OF THE PIPE. STRAPS FOR VERTICAL BENDS SHALL BE GALVANIZED WITH MINIMUM DIMENSIONS OF 3/16" X 2-1/2". THE LENGTH OF THE STRAPS SHALL BE DESIGNED TO PROVIDE A MINIMUM EMBEDMENT OF 12 INCHES AND INCLUDE BENT STIRRUPS TO PROVIDE ANCHORAGE.



2806 Bryan Road • Van Buren, Arkansas
(479) 474-5067

Pipe Blocking for Bends and Tees

Filename: T11 PIPE BLOCKING.DWG

May 2014

Sheet:

T11

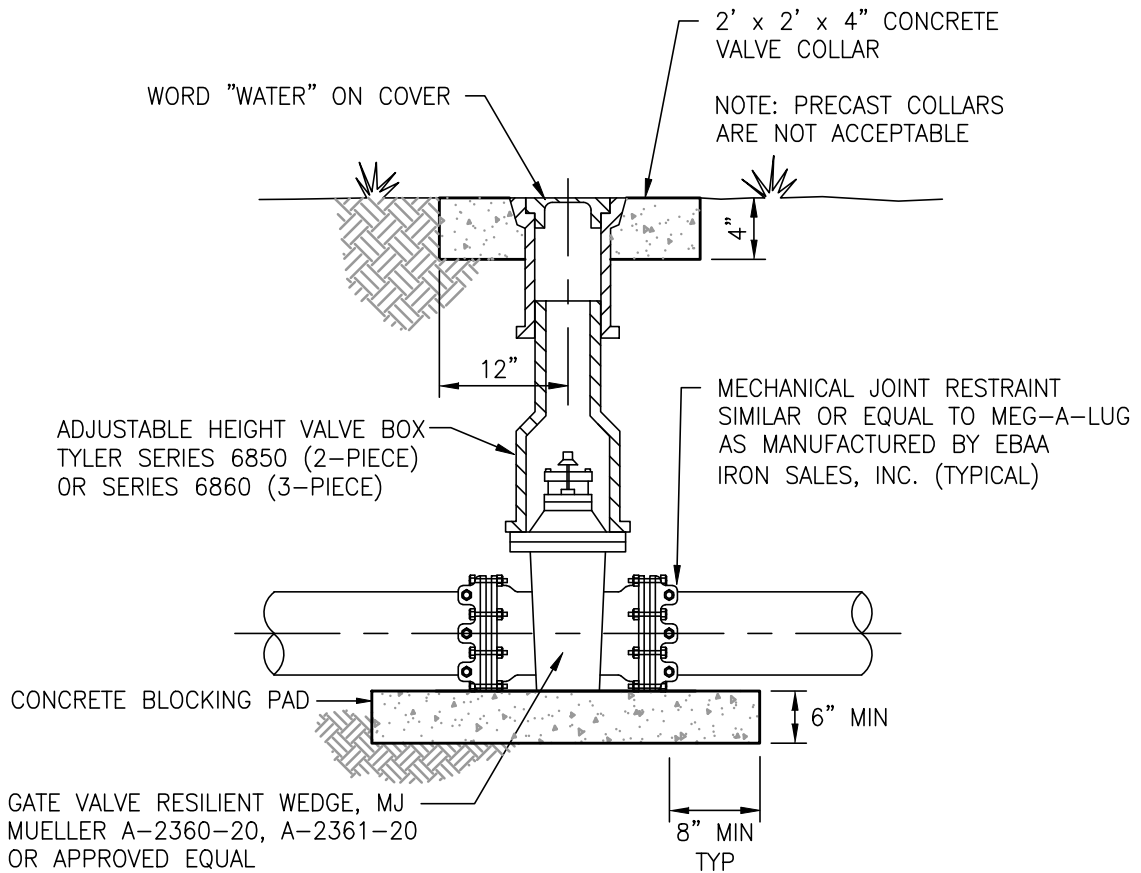

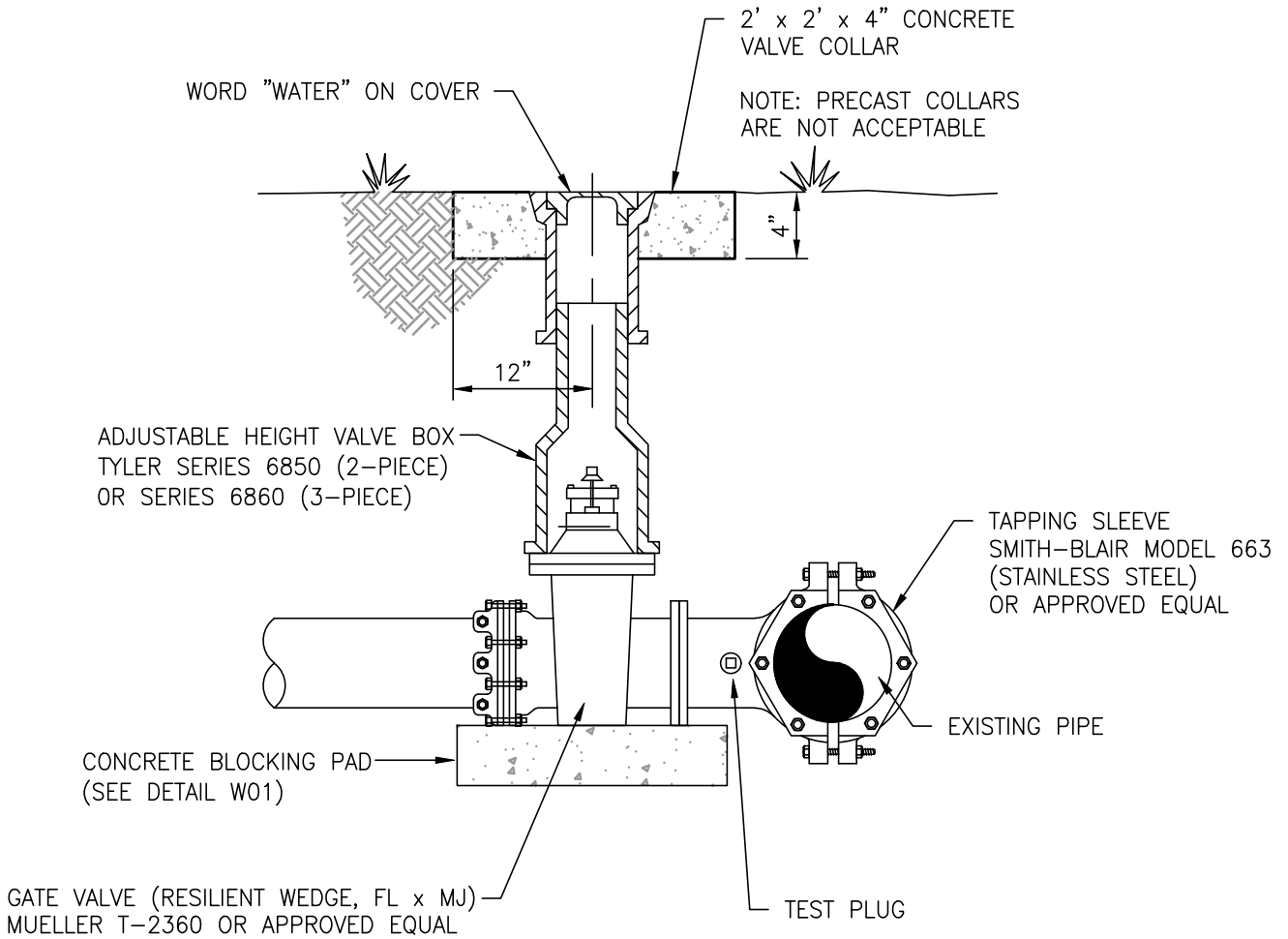

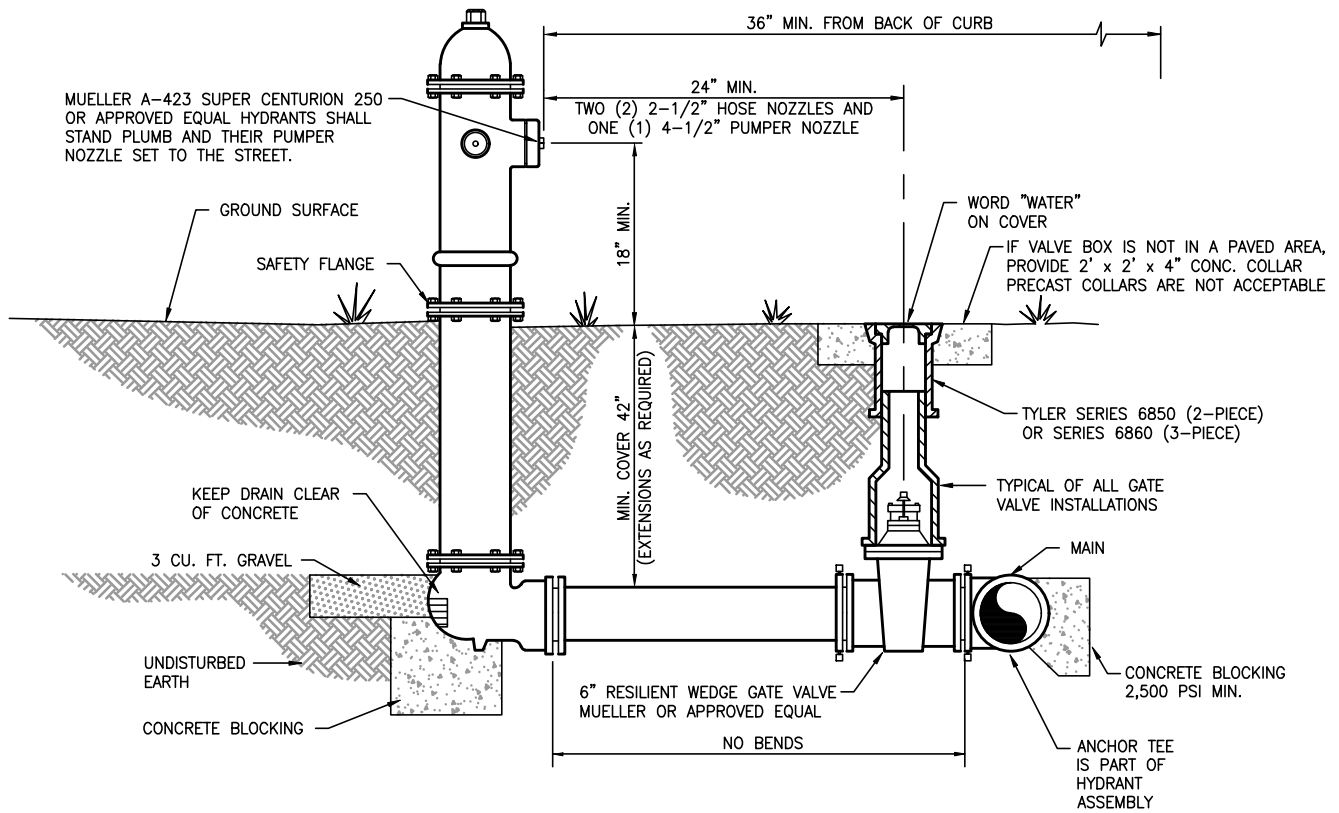

VUB MUNICIPAL UTILITIES

2806 Bryan Road • Van Buren, Arkansas
(479) 474-5067

Fire Hydrant Assembly

Filename: W03 FIRE HYDRANT ASSEMBLY.DWG

May 2014

Sheet:

W03

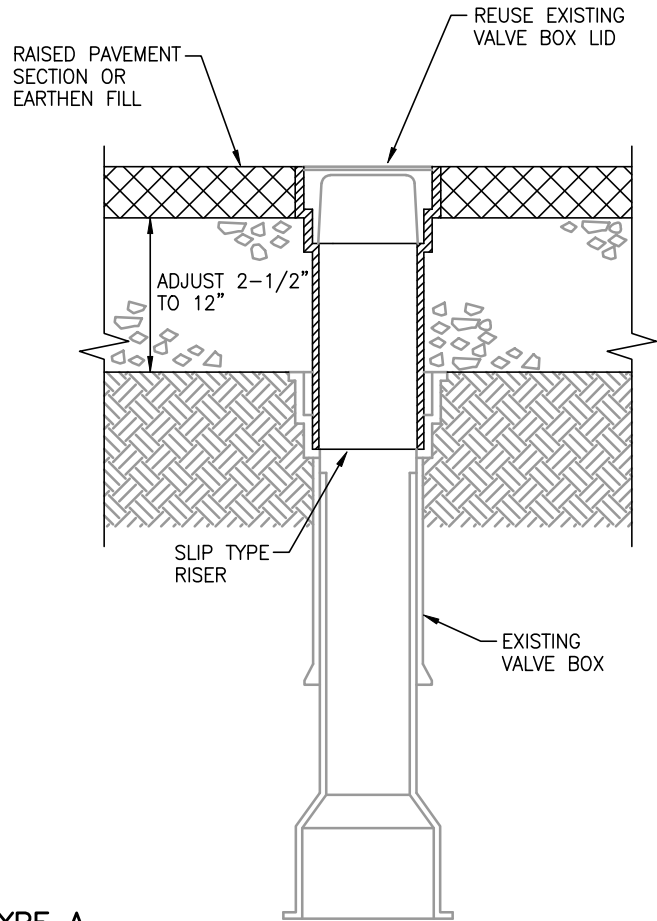
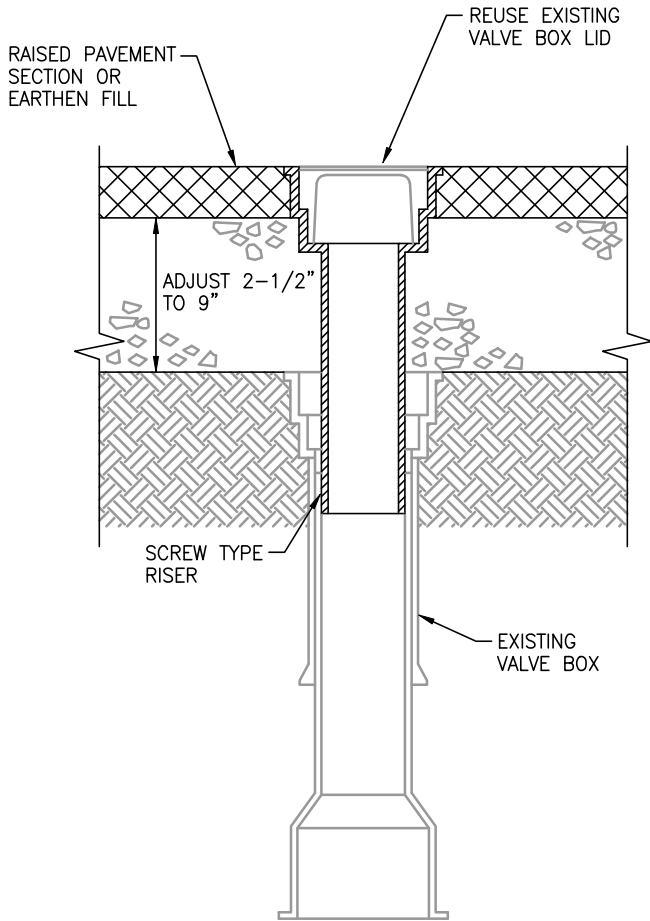

TYPE A

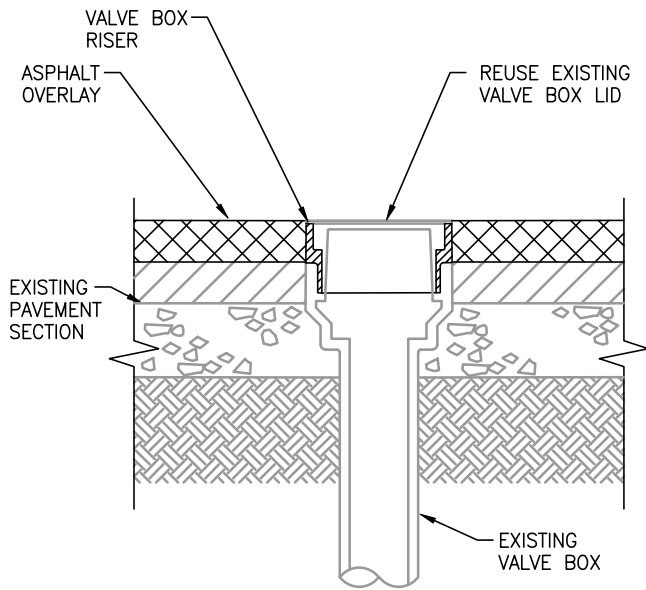

TYPE B

NOTES:

1. VALVE BOX RISER SECTIONS FOR TYPE "A" ADJUSTMENT SHALL BE TYLER #69 SCREW TYPE ADJUSTABLE RISER, TYLER #69-A SLIP TYPE ADJUSTABLE RISER, OR APPROVED EQUAL. CONFIRM RISER HEIGHT TO MATCH FINAL PAVEMENT OR BACKFILL GRADE. RISER SECTION SHALL BE SUITABLE FOR USE WITH A 5-1/4" DROP-IN LID.
2. VALVE BOX RISER FOR TYPE "B" ADJUSTMENT SHALL BE TYLER 2-1/4" SLIP-IN RISER OR APPROVED EQUAL.
3. REPLACE VALVE BOX LIDS AS NECESSARY. LETTERING FOR STANDARD 5-1/4" REPLACEMENT LIDS SHALL BE "WATER" OR AS INDICATED ON THE PLANS.

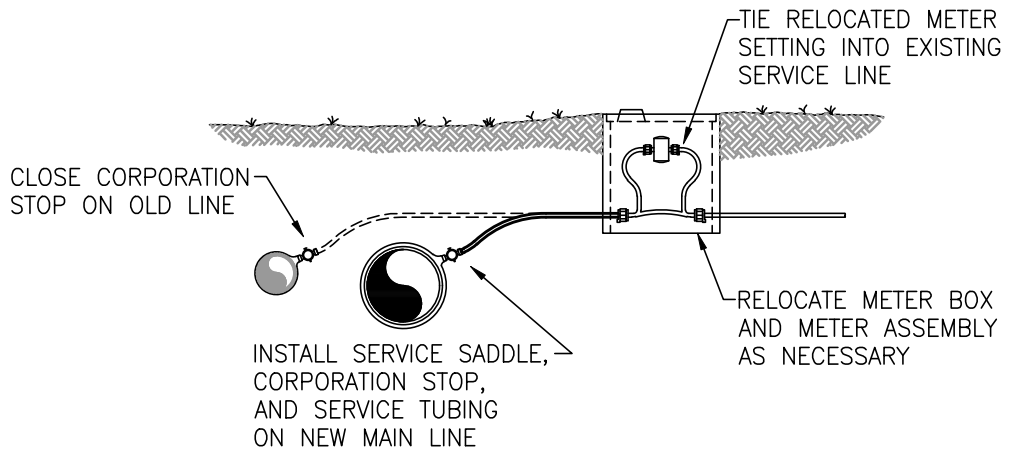

SERVICE METER CONNECTION

N.T.S.

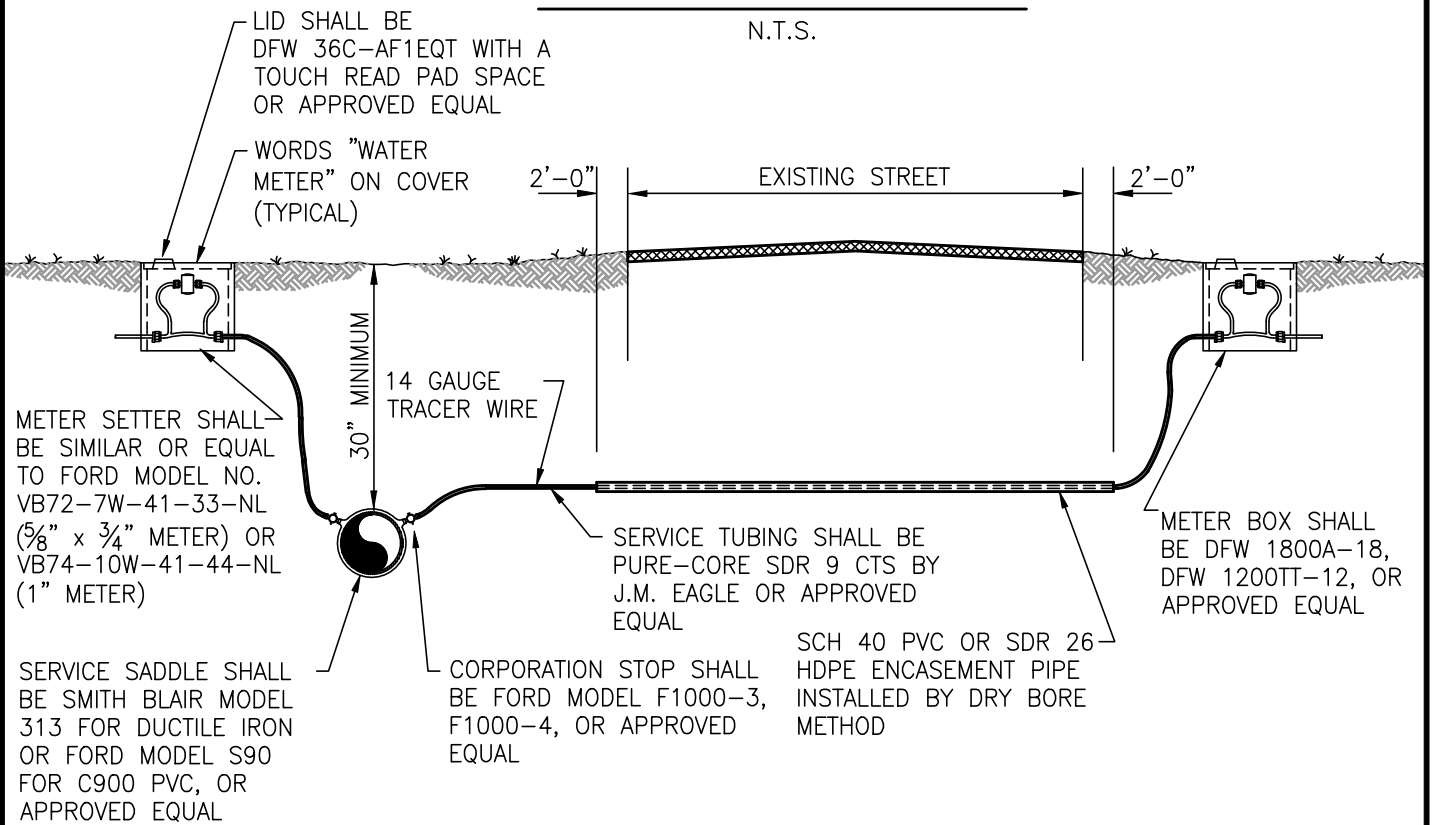

SEE SPECIFICATION SECTION 310-WATER LINE IMPROVEMENTS FOR METER BOX REQUIREMENTS BASED ON LIGHT TRAFFIC AREAS, SIDEWALKS AND PAVED AREAS

VB MUNICIPAL UTILITIES

2806 Bryan Road • Van Buren, Arkansas
(479) 474-5067

Water Service Meter Connection

Filename: W05 WATER SERVICE CONNECTION.DWG

May 2014

Jan 2022

Sheet:

W05

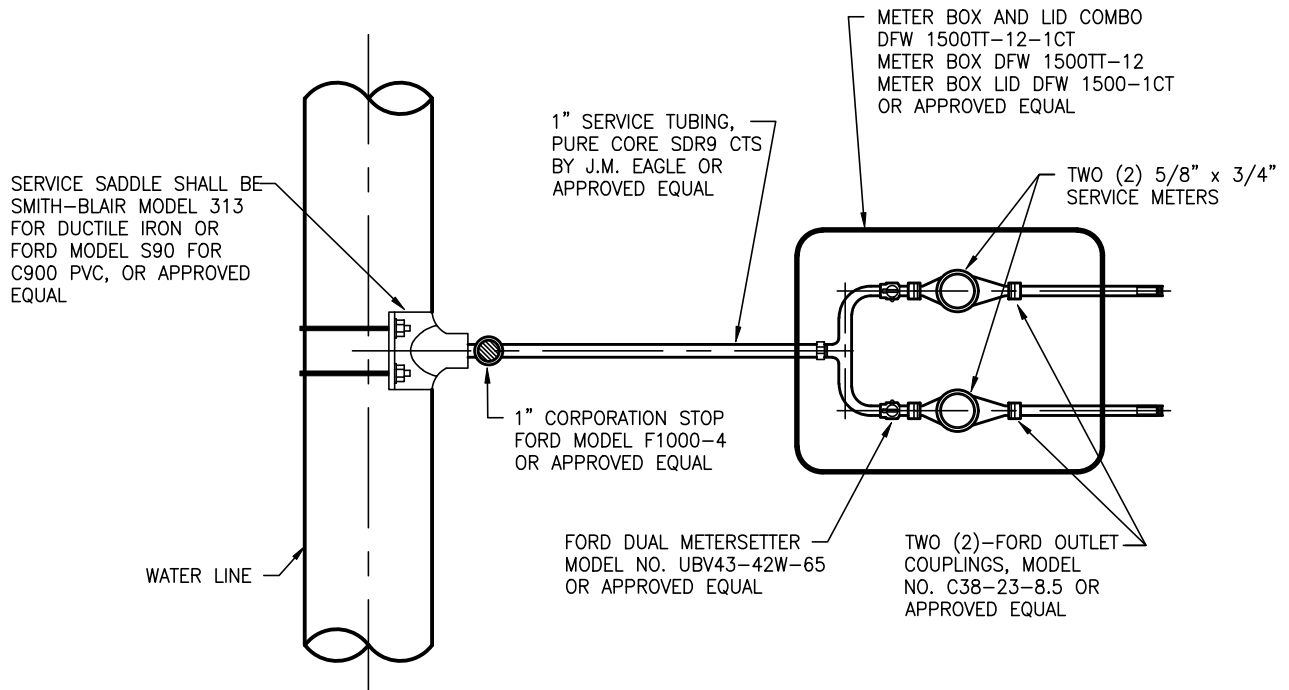

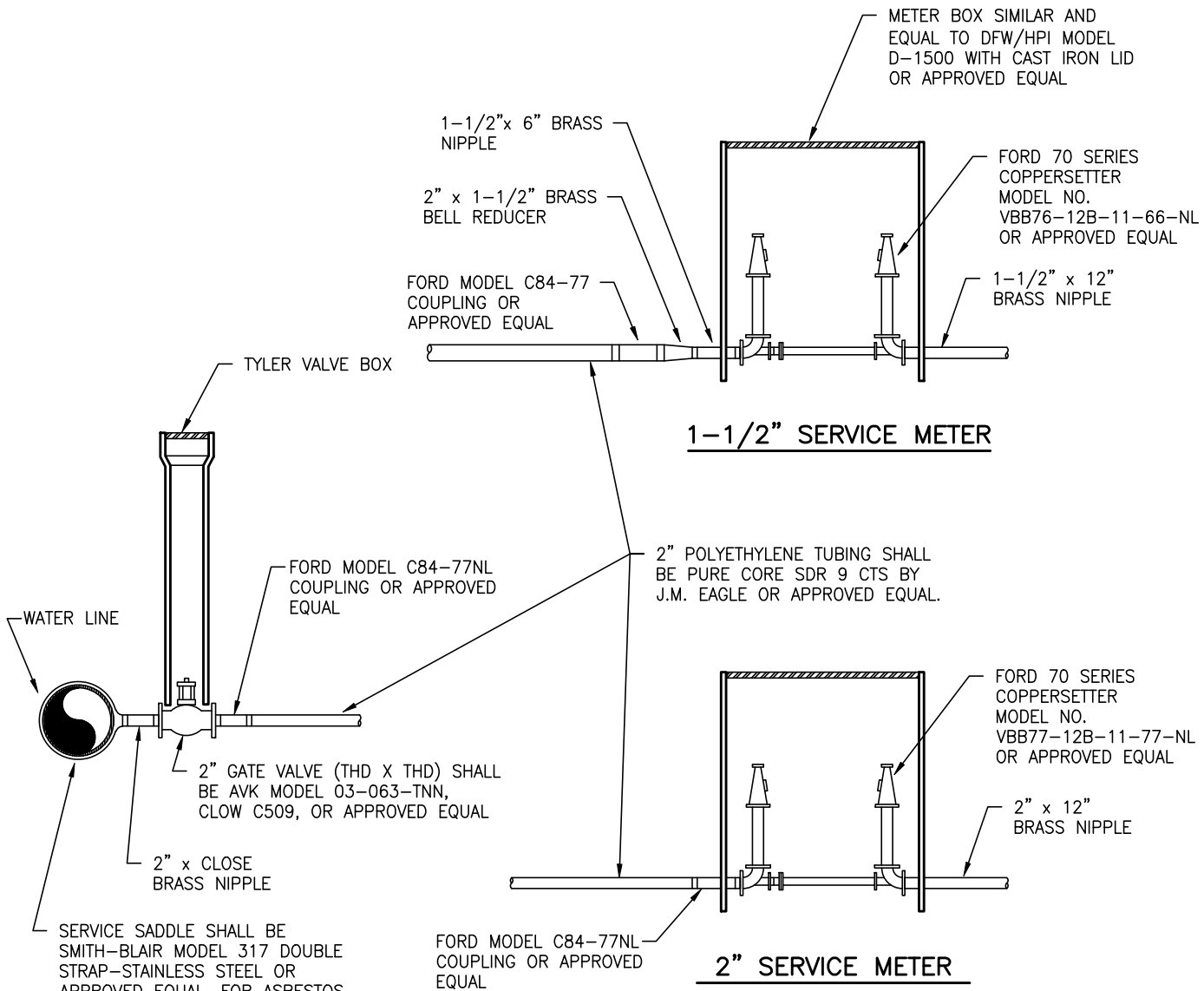

SERVICE SADDLE SHALL BE SMITH-BLAIR MODEL 317 DOUBLE STRAP-STAINLESS STEEL OR APPROVED EQUAL. FOR ASBESTOS CEMENT PIPE, INSTALL SMITH-BLAIR MODEL 313 IRON-DOUBLE BALE OR APPROVED EQUAL.

NOTES:

1. METER SETTERS SHALL BE INSTALLED IN ACCORDANCE WITH THE MANUFACTURERS RECOMMENDATIONS.
2. PRIOR TO CONSTRUCTION, METER SIZE AND TYPE SHALL BE COORDINATED WITH VAN BUREN MUNICIPAL UTILITIES.
3. WATER METERS SHALL BE PROVIDED AND SET BY VAN BUREN MUNICIPAL UTILITIES IN A BOX AND SETTER PROVIDED BY THE DEVELOPER.

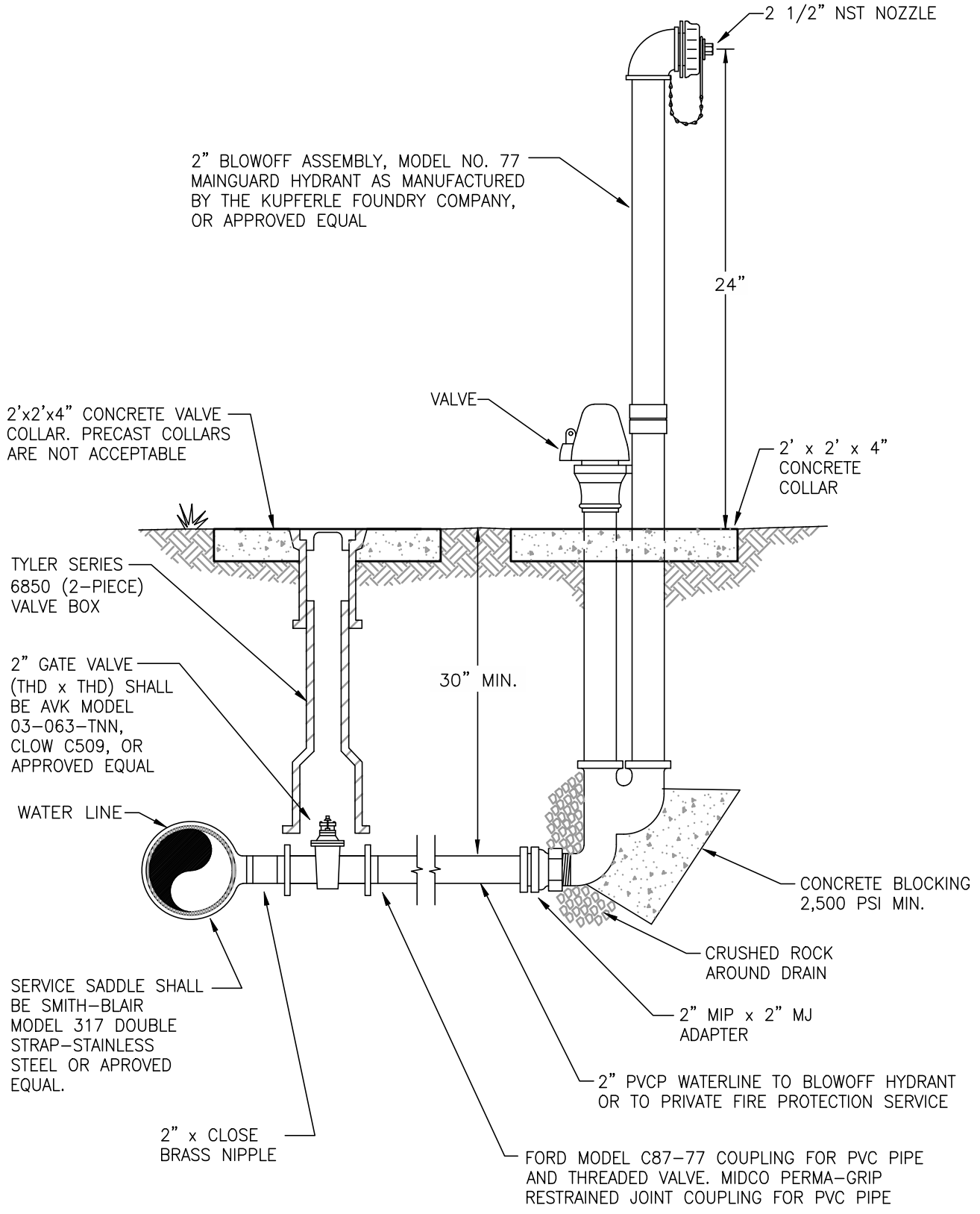

AIR/VACUUM VALVE ASSEMBLY NOTES

1. CONTRACTOR SHALL BACKFILL OVER THE LINE WITH GRAVEL TO A POINT 12-INCHES (MINIMUM) ABOVE THE TOP OF PIPE. A CONCRETE FOUNDATION PAD AND VAULT SHALL THEN BE CONSTRUCTED OVER THE WATER LINE.
2. THE 6-INCH VENT PIPE SHALL BE CLEANED AND PAINTED WITH SHERWIN-WILLIAMS, RUST-OLEUM OR EQUIVALENT PAINT. PAINT SHALL BE EPOXY, SUITABLE FOR EXTERIOR USAGE, AND APPLIED IN A MINIMUM OF (2) COATS, 4-MILS DRY EACH.
3. FOR EACH AIR, AIR/VACUUM OR COMBINATION VALVE VAULT, THE CONTRACTOR SHALL TAP THE LINE, PROVIDE A FACTORY INSTALLED WELDED FLANGE OUTLET, OR INSTALL A RESTRAINED JOINT TEE. A FLANGED DUCTILE IRON PIPE EXTENSION SHALL BE INSTALLED ON THE TAP TO RAISE THE ISOLATION VALVE ABOVE THE LEVEL OF THE VAULT'S BOTTOM SLAB.
4. CONTRACTOR SHALL INSTALL AN AIR RELEASE VALVE OR A COMBINATION AIR VALVE OF THE SIZE AND TYPE SHOWN ON THE PLANS. THE VALVE SHALL INCLUDE AN ISOLATION GATE VALVE AND ANTI-SLAM DEVICE WHERE REQUIRED.
5. IF VAULT IS INSTALLED IN PAVED AREA, VENT SHALL BE INSTALLED THRU WALL OF VAULT AND RUN AT A 2% SLOPE OUT A MINIMUM OF 3 FEET BEYOND THE PAVED AREA.
6. AIR RELEASE VALVES FOR WATER SERVICE SHALL BE CLEAN WATER AIR RELEASE VALVES WITH VACUUM CHECK AND NSF 61 EPOXY COATING BY VAL-MATIC VALVE AND MANUFACTURING CORP OR APPROVED EQUAL. AIR/VACUUM AND COMBINATION AIR RELEASE VALVES FOR WASTEWATER SERVICE SHALL BE D-020 OR D-023 SERIES VALVES BY A.R.I. WITH STAINLESS VALVE BODIES OR APPROVED EQUAL.
7. AIR VALVES 3-INCHES AND LARGER SHALL HAVE FLANGED CONNECTIONS. ALL OTHERS MAY HAVE THREADED CONNECTIONS.

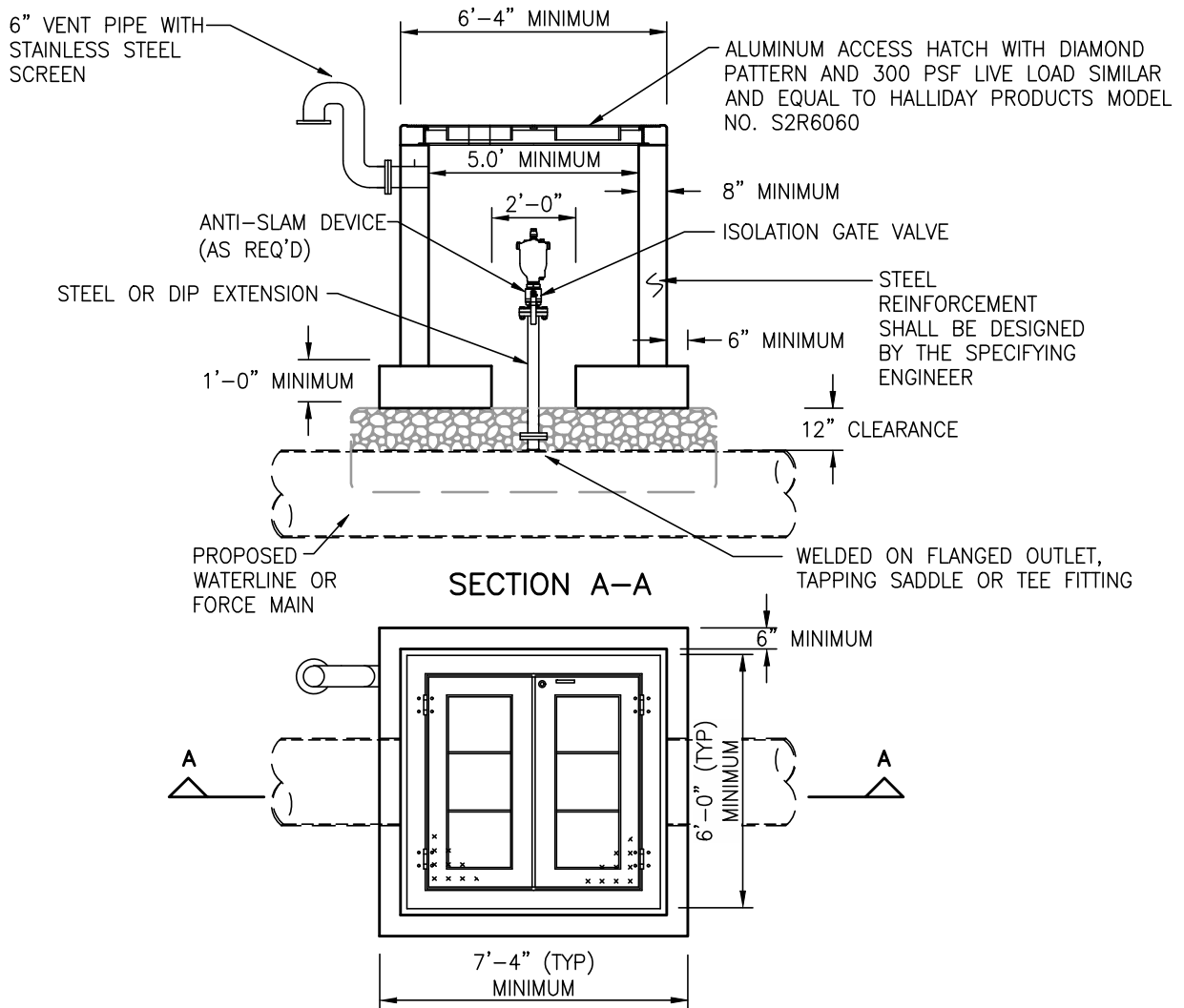

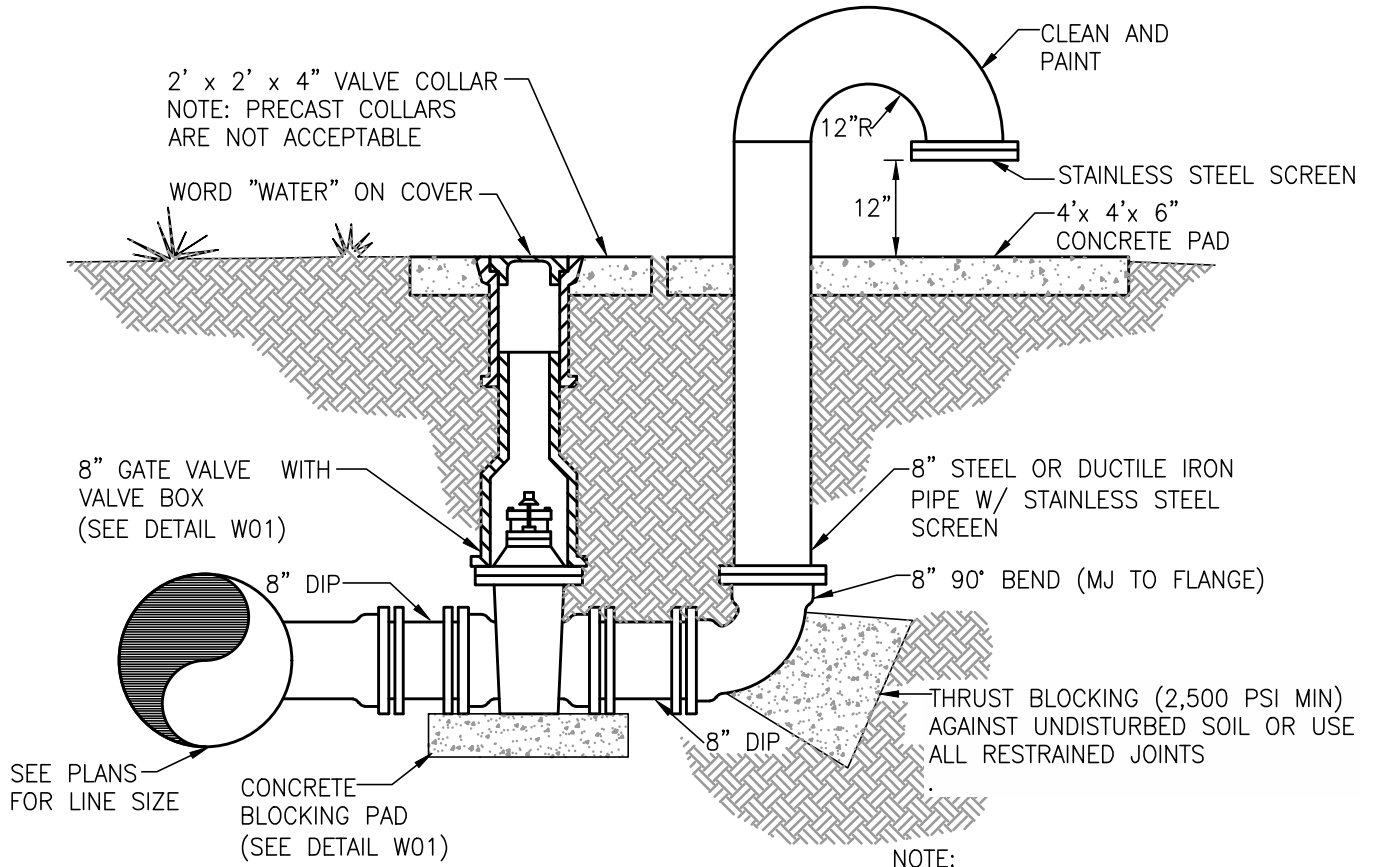

NOTE:
 THE 8-INCH VENT PIPE SHALL BE CLEANED AND PAINTED WITH SHERWIN-WILLIAMS, RUST-OLEUM OR EQUIVALENT PAINT. PAINT SHALL BE EPOXY, SUITABLE FOR EXTERIOR USAGE, AND APPLIED IN A MINIMUM OF (2) COATS, 4-MILS DRY EACH.

May 2014
Jan 2022

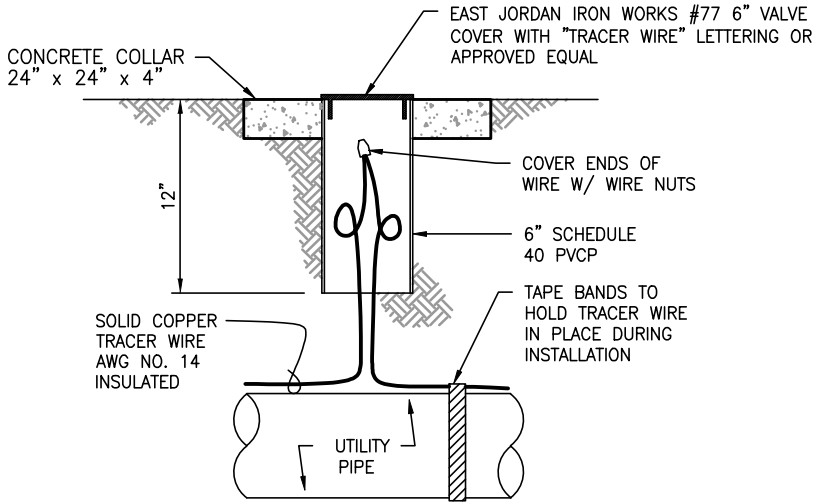

NOTES:

1. WIRE SPLICES SHALL BE ELECTRICALLY BONDED AND SHALL BE SECURED WITH SPLICING CLIPS TO RELIEVE ANY TENSION ON THE SPLICE.
2. TERMINAL BOXES SHALL BE LOCATED AT APPROX. INTERVALS OF 500' OF PIPE LENGTH, AND AT EACH END OF THE PIPING INSTALLATION.
3. TERMINAL BOXES SHALL BE LOCATED ON THE PLANS WITH THE SYMBOL "△".
4. THE CONTRACTOR SHALL PROVIDE AN INSTRUMENT AND DEMONSTRATE THE ELECTRICAL CONTINUITY OF ALL TRACER WIRES PRIOR TO THE FINAL ACCEPTANCE BY THE VAN BUREN MUNICIPAL UTILITIES.
5. TRACER WIRE SHALL BE INSTALLED IN THE LOCATION DIRECTED BY THE ENGINEER BUT SHALL GENERALLY BE LOCATED IMMEDIATELY ADJACENT TO THE PIPE AND AT THE SAME DEPTH.

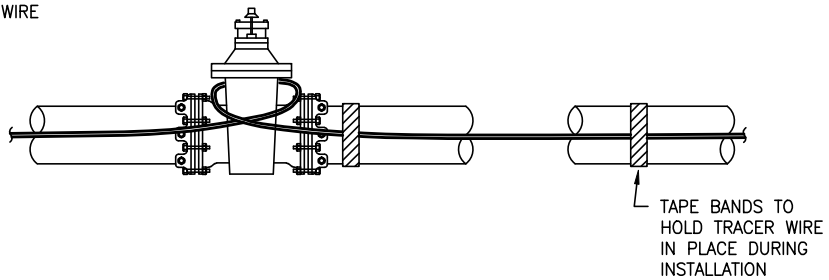
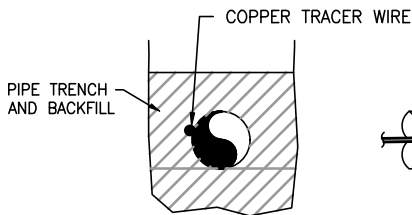

VB MUNICIPAL UTILITIES

2806 Bryan Road • Van Buren, Arkansas
(479) 474-5067

Tracer Wire and Terminal Box

Filename: W11 TRACER WIRE.DWG

May 2014

Sheet:

W11

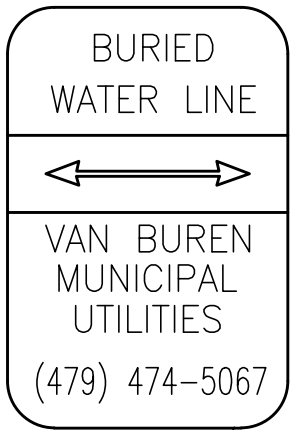
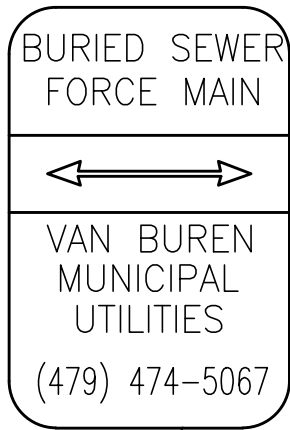

6" x 9" ALUMINUM PLATE
GREEN BACKGROUND W/
BLACK LETTERING

6" x 9" ALUMINUM PLATE
BLUE BACKGROUND W/
BLACK LETTERING

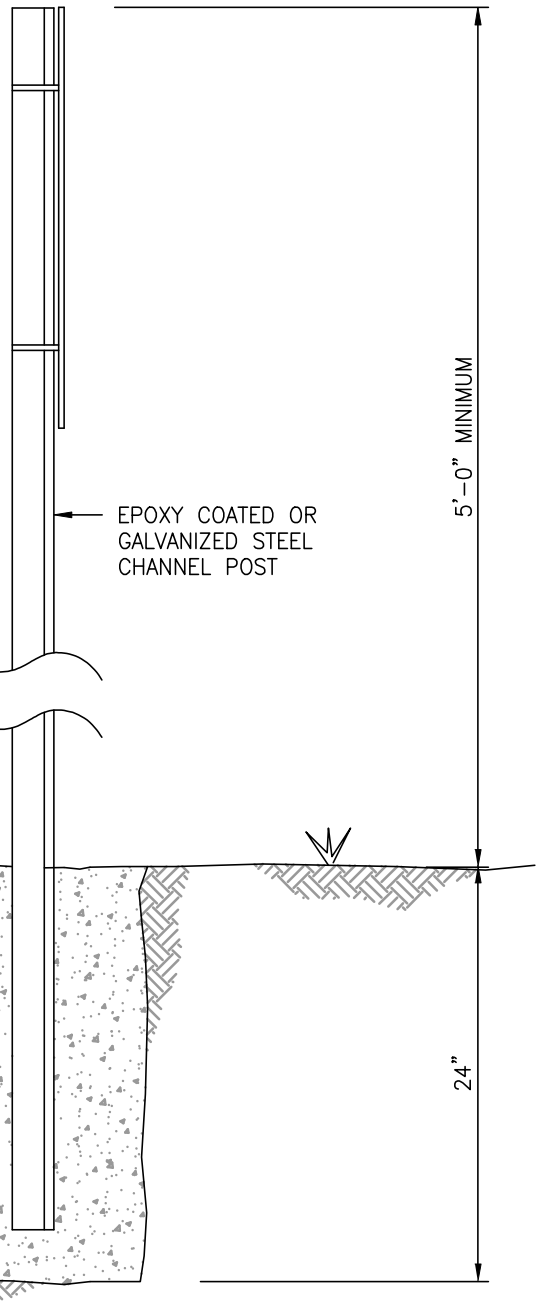

EPOXY COATED OR
GALVANIZED STEEL
CHANNEL POST

5'-0" MINIMUM

24"

SET POST IN CONCRETE
2,500 PSI MIN.

NOTE:

WATER MAINS AND SANITARY SEWERS SHALL BE CONSTRUCTED AS FAR APART AS PRACTICABLE, AND SHALL BE SEPARATED BY UNDISTURBED AND COMPACTED EARTH. A MINIMUM HORIZONTAL DISTANCE OF TEN FEET SHOULD BE MAINTAINED BETWEEN WATER LINES AND SEWER LINES OR OTHER SOURCES OF CONTAMINATION. WATER LINES AND SEWERS SHALL NOT BE LAID IN THE SAME TRENCH EXCEPT ON THE WRITTEN APPROVAL OF THE ARKANSAS DEPARTMENT OF HEALTH. WATER MAINS NECESSARILY IN CLOSE PROXIMITY TO SEWERS MUST BE PLACED SO THAT THE BOTTOM OF THE WATER LINE WILL BE AT LEAST 18 INCHES ABOVE THE TOP OF THE SEWER LINE AT ITS HIGHEST POINT. IF THIS DISTANCE MUST UNAVOIDABLY BE REDUCED, THE WATER LINE OR THE SEWER LINE MUST BE ENCASED IN WATERTIGHT PIPE WITH SEALED WATERTIGHT ENDS EXTENDING AT LEAST TEN FEET EITHER SIDE OF THE CROSSING. ANY JOINT IN THE ENCASEMENT PIPE IS TO BE MECHANICALLY RESTRAINED. THE ENCASEMENT PIPE MAY BE VENTED TO THE SURFACE IF CARRYING WATER OR SEWER UNDER PRESSURE. WHERE A WATER LINE MUST UNAVOIDABLY PASS BENEATH THE SEWER LINE, AT LEAST 18 INCHES OF SEPARATION MUST BE MAINTAINED BETWEEN THE OUTSIDE OF THE TWO PIPES IN ADDITION TO THE PRECEDING ENCASEMENT REQUIREMENT. EXCEPTIONS TO THIS MUST BE APPROVED IN WRITING BY THE ARKANSAS DEPARTMENT OF HEALTH.

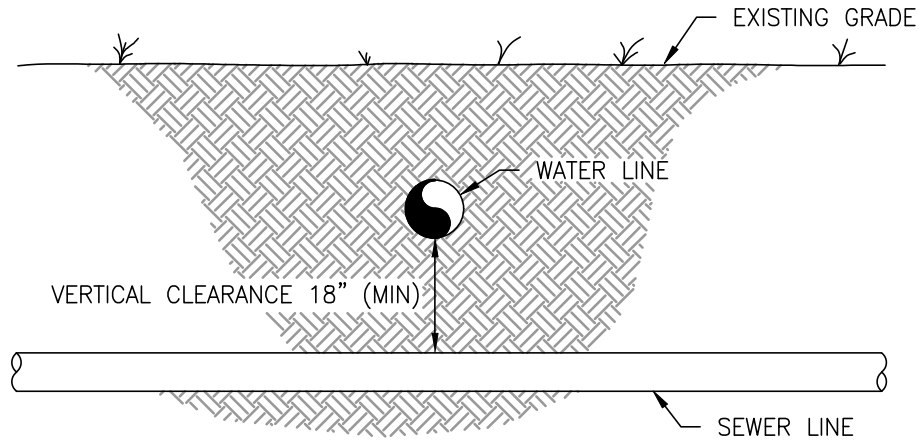

2806 Bryan Road • Van Buren, Arkansas
(479) 474-5067

Water and Sewer Line Separation

Filename: W13 WATER SEWER LINE SEPARATION.DWG

May 2014

Jan 2022

Sheet:

W13

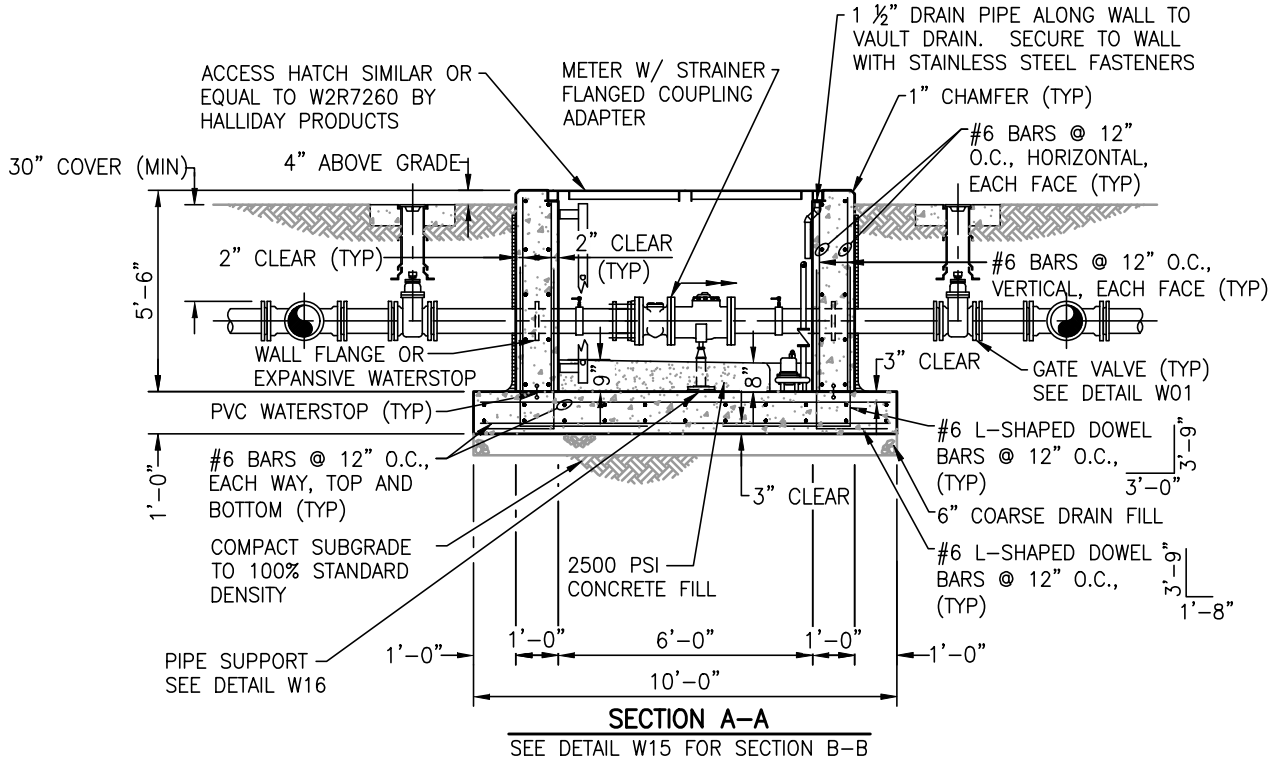
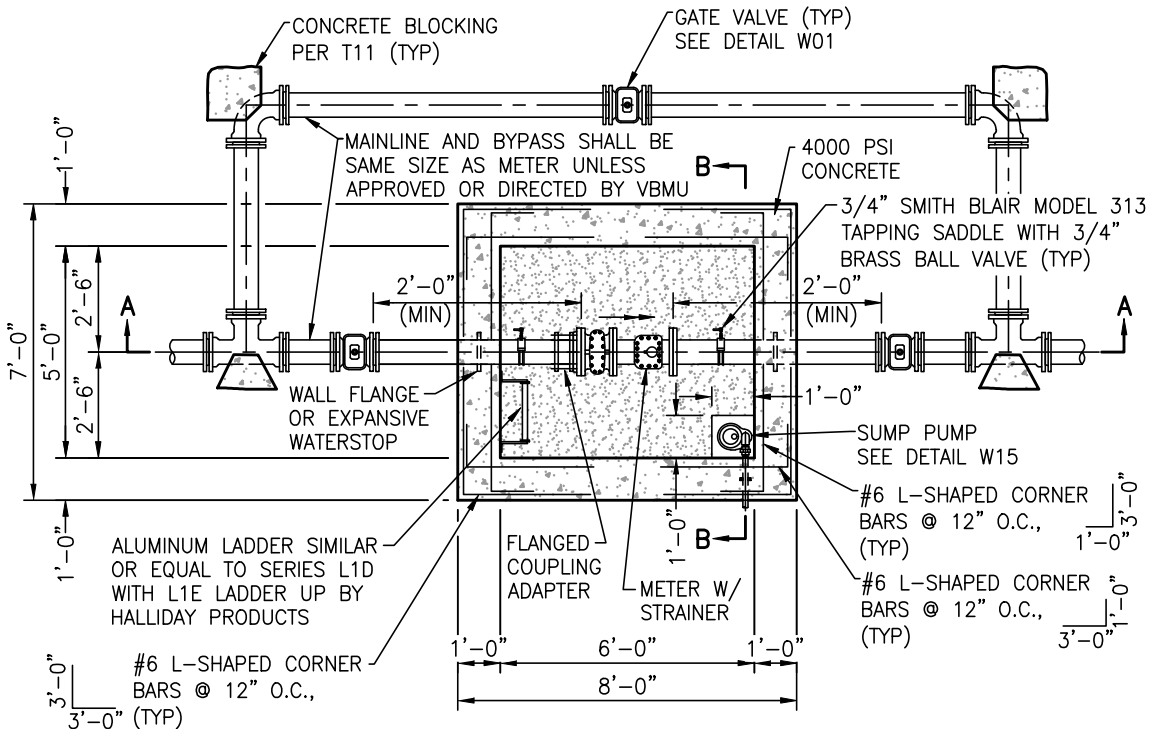

VBM MUNICIPAL UTILITIES

2806 Bryan Road • Van Buren, Arkansas
(479) 474-5067

Water Meter Vault
3" and 4" Meters

Filename: W14 WATER METER VAULT.DWG

May 2014

Jan 2022

Sheet:

W14

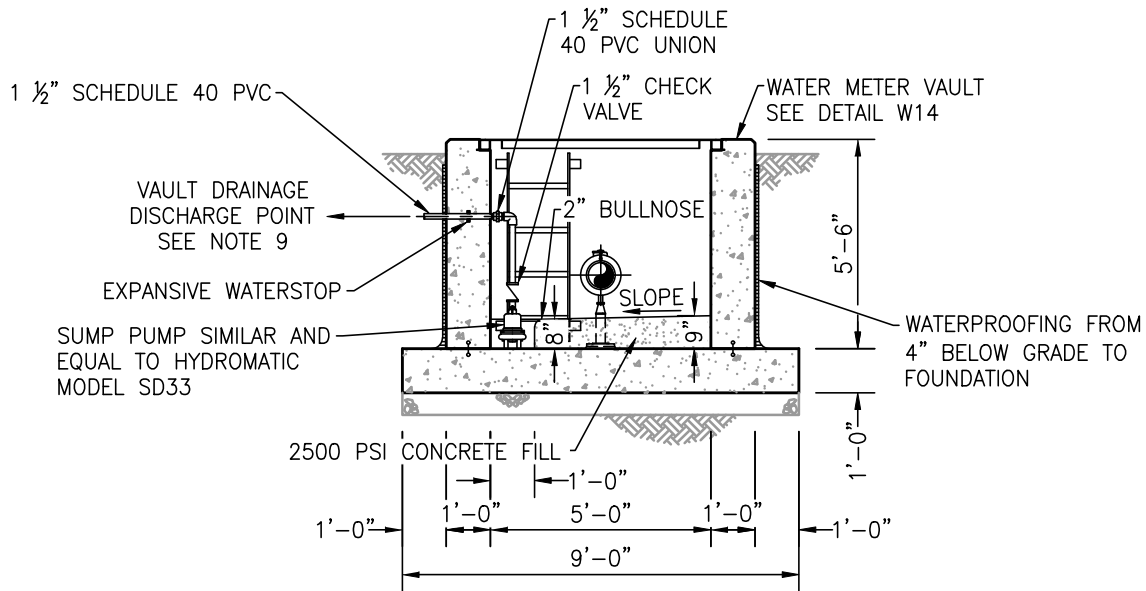

SECTION B-B

NOTES:

1. METERS SHALL BE PROVIDED AND SET BY VAN BUREN MUNICIPAL UTILITIES IN A VAULT PROVIDED BY THE DEVELOPER.
2. PRIOR TO CONSTRUCTION, METER SIZE AND TYPE SHALL BE COORDINATED WITH VAN BUREN MUNICIPAL UTILITIES.
3. METERS SHALL BE INSTALLED IN ACCORDANCE WITH THE MANUFACTURER'S RECOMMENDATIONS.
4. ALL PIPING AND FITTINGS SHALL BE DUCTILE IRON.
5. MAINLINE AND BYPASS SHALL BE SAME DIAMETER AS METER ASSEMBLY UNLESS OTHERWISE APPROVED OR DIRECTED BY VBMU.
6. COORDINATE WITH VBMU TO PROVIDE SUITABLE ELECTRICAL SERVICE FOR THE SUMP PUMP.
7. PRECAST VAULTS OR REQUESTS FOR DETAIL VARIANCE SHALL BE SUBMITTED TO VBMU FOR REVIEW AND APPROVAL PRIOR TO CONSTRUCTION.
8. COARSE DRAIN FILL PER ASTM C33 (3/4" MAXIMUM AGGREGATE SIZE) SHALL BE COMPACTED WITH A MINIMUM OF TWO (2) PASSES OF A VIBRATORY PLATE.
9. VAULT DRAINAGE DISCHARGE POINT MUST BE APPROVED BY THE CITY OF VAN BUREN BUILDING DEPARTMENT PRIOR TO CONSTRUCTION. VAULT DRAINAGE SHALL NOT BE DISCHARGED TO THE SANITARY SEWER COLLECTION SYSTEM. VAULTS WITH GRAVITY DRAINS (WHERE A SUMP PUMP IS NOT REQUIRED) SHALL INCLUDE A FLAP VALVE OR DUCK BILL CHECK VALVE INSTALLED ON THE DISCHARGE TO PREVENT MATERIAL ENTERING THE VAULT FROM THE DRAIN.
10. VAULTS FOR 6-INCH AND LARGER WATER METERS REQUIRE SUBMITTAL OF DESIGN DRAWINGS PREPARED BY AN ARKANSAS LICENSED PROFESSIONAL ENGINEER FOR REVIEW AND APPROVAL BY VBMU.



2806 Bryan Road • Van Buren, Arkansas
(479) 474-5067

**Water Meter Vault
3" and 4" Meters**

Filename: W15 WATER METER VAULT II.DWG

Jan 2022

Sheet:

W15

'U' BOLT PIPE SUPPORT
GRINNELL FIG
259 OR EQUAL.

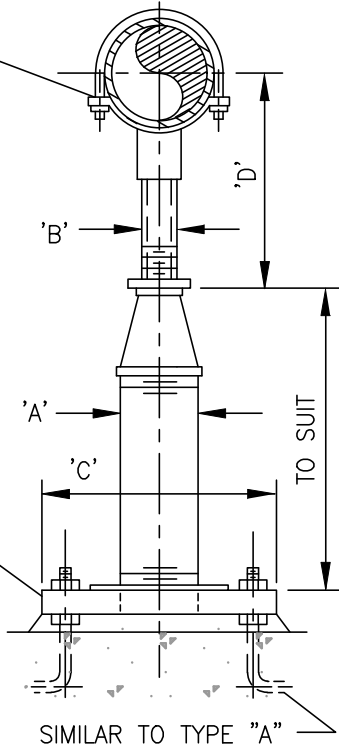

TYPE "B"

ADJUSTABLE PIPE SUPPORT APPROX. DIMENSIONS IN INCHES					
PIPE SIZE	A	B	C	D MIN	D MAX
2-1/2	2-1/2	1-1/2	9	8	13
3	2-1/2	1-1/2	9	8-1/4	13-1/4
3-1/2	2-1/2	1-1/2	9	8-1/2	13-1/2
4	3	2-1/2	9	9-1/4	14
6	3	2-1/2	9	10-1/2	15-1/4
8	3	2-1/2	9	11-3/4	16-1/2
10	3	2-1/2	9	13-1/2	18-1/4
12	3	2-1/2	9	15	19-3/4
14	4	3	11	16-1/4	20-3/4
16	4	3	11	17-3/4	22-1/4
18	6	3-1/2	13-1/2	19-1/2	24
20	6	3-1/2	13-1/2	21	25-1/2
24	6	4	13-1/2	23-3/4	28-1/4
30	6	4	13-1/2	27	31-1/2
32	6	4	13-1/2	28-1/4	32-3/4
36	6	4	13-1/2	30-1/4	34-3/4

150 LB THREADED
REDUCING FLANGE,
GALVANIZED

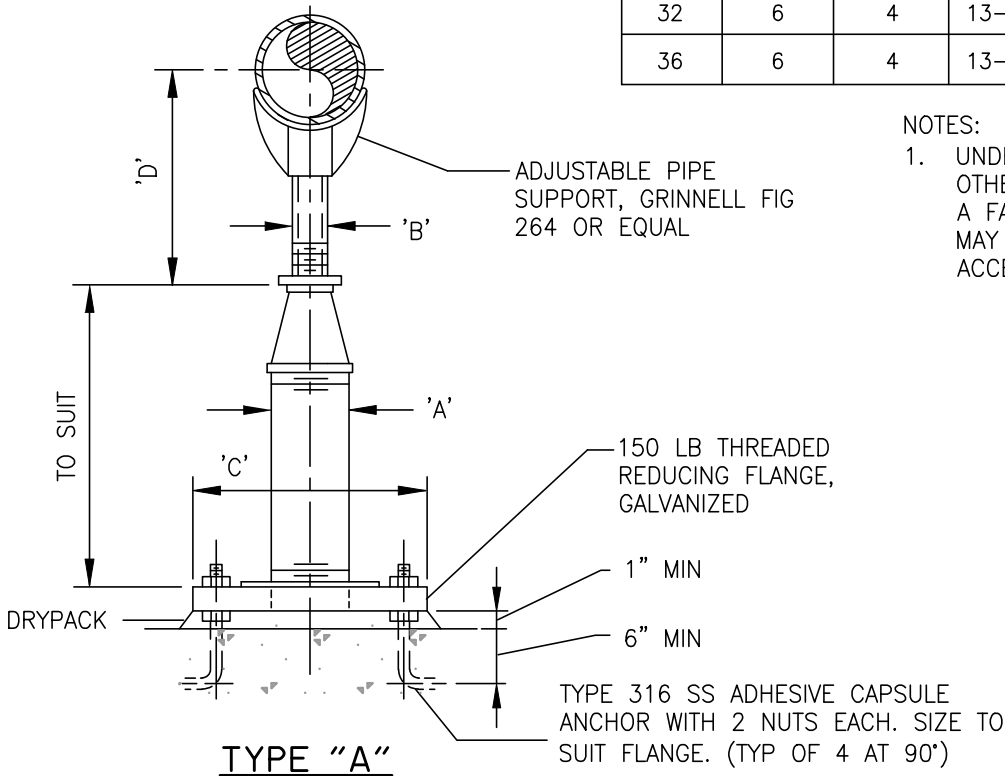

TYPE "A"

NOTES:

1. UNDER VALVES, METERS OR OTHER SPECIAL APPURTENANCES, A FABRICATED SUPPORT PIECE MAY BE UTILIZED AS ACCEPTABLE TO ENGINEER.

VB MUNICIPAL UTILITIES

2806 Bryan Road • Van Buren, Arkansas
(479) 474-5067

ADJUSTABLE PIPE SUPPORT

Filename: W16 ADJUSTABLE PIPE SUPPORT.DWG

Jan 2022

Sheet:

W16